

# **MIRO Experiment User Manual**

Prepared by:

Margaret Frerking  
Samuel Gulkis  
Lucas Kamp  
Timothy Koch  
Robert Nowicki

Approved by

---

Samuel Gulkis  
MIRO Principal Investigator

---

Date

**This page is intentionally left blank**

## Table of Contents

<b>1</b>	<b>OVERVIEW .....</b>	<b>15</b>
1.1	SCIENTIFIC OBJECTIVES .....	15
1.1.1	<i>Introduction</i> .....	15
1.1.2	<i>Science Objectives and Investigation</i> .....	16
1.1.3	<i>Measurement Approach</i> .....	19
1.1.4	<i>MIRO Science Data Deliverables</i> .....	19
1.2	HARDWARE DESCRIPTION .....	20
1.2.1	<i>Introduction</i> .....	20
1.2.1.1	Performance Characteristics .....	20
1.2.1.2	System Overall Configuration .....	20
1.2.2	<i>Detailed Description</i> .....	23
1.2.2.1	Telescope .....	23
1.2.2.2	Calibration Targets .....	23
1.2.2.3	Millimeter-Wave Heterodyne Receiver .....	24
1.2.2.4	Submillimeter Wave Heterodyne Receiver .....	25
1.2.2.5	Spectrometer Assembly .....	28
1.2.2.6	Flight Computer .....	29
1.2.2.7	Command and Data Handling System .....	29
1.2.2.8	Power Handling and Distribution .....	30
1.3	SOFTWARE DESCRIPTION .....	30
1.3.1	<i>Flight Software Development Environment</i> .....	30
1.4	OPERATIONAL MODES .....	30
<b>2</b>	<b>EXPERIMENT CONFIGURATION .....</b>	<b>32</b>
2.1	PHYSICAL UNITS .....	32
2.2	CALIBRATION SWITCH MECHANISM .....	35
2.3	ELECTRICAL .....	37
2.3.1	<i>Power Interface</i> .....	37
2.3.1.1	General Interface Description .....	37
2.3.1.2	Power Distribution Block Diagram and Redundancy .....	37
2.3.1.3	Experiment Power Requirements .....	39
2.4	SOFTWARE .....	40
2.4.1	<i>Overview</i> .....	40
2.4.2	<i>Commanding</i> .....	41
2.4.3	<i>Hardware Interfaces</i> .....	43
2.4.4	<i>Spectral Data Interface</i> .....	43
2.4.4.1	CTS Control .....	43
2.4.4.2	PLL, LO and IFP Control .....	45
2.4.5	<i>Continuum Data Interface</i> .....	45
2.4.6	<i>Engineering Data Interface</i> .....	46
2.4.7	<i>Power Interfaces</i> .....	47
2.4.8	<i>Mirror Control Interface</i> .....	48
2.4.9	<i>Pin-Puller Control</i> .....	48
2.4.10	<i>Inbound FIFO Interface</i> .....	49
2.4.11	<i>Outbound FIFO Interface</i> .....	49
2.4.12	<i>Interrupts Interface</i> .....	49
2.5	BUDGETS (MASS, POWER, DATA RATES) .....	50
2.5.1	<i>Mass</i> .....	50
2.5.2	<i>Operating Power</i> .....	50
2.5.3	<i>Data Rates</i> .....	51
2.6	NON-OPERATING HEATERS .....	51

2.7	SPACECRAFT POWERED THERMISTORS.....	51
2.8	PYRO LINES .....	51
2.9	OBDH CHANNEL .....	52
2.9.1	<i>Channel Allocation</i> .....	52
2.9.2	<i>Telemetry</i> .....	52
2.9.3	<i>Telecommand</i> .....	52
2.9.4	<i>Bit Rate Requirements</i> .....	52
2.9.5	<i>Timing</i> .....	53
2.9.6	<i>Monitoring</i> .....	53
2.9.6.1	Telecommands and Verification.....	53
2.9.6.2	Experiment Status and Event Reporting .....	53
2.9.7	<i>Electrical Interfaces Circuits</i> .....	53
2.9.7.1	General .....	53
2.9.7.2	Telemetry .....	53
2.9.7.3	Telecommand.....	55
2.9.7.4	Broadcast Pulse (TSY).....	56
2.9.7.5	Environmental and Status Monitoring .....	56
2.9.7.6	Redundancy.....	56
2.9.8	<i>On-board Operational Interface with DMS</i> .....	56
2.9.8.1	Telecommand.....	57
2.9.8.2	Telemetry .....	57
<b>3</b>	<b>EXPERIMENT OPERATIONS.....</b>	<b>58</b>
3.1	OPERATING PRINCIPLES.....	58
3.1.1	<i>Instrument Power On, Warmup, and Stabilization</i> .....	58
3.1.2	<i>Functional Tests</i> .....	58
3.1.3	<i>In-Flight Calibration Observations</i> .....	58
3.1.3.1	Radiometric.....	60
3.1.3.2	Frequency.....	60
3.1.3.3	Field of View .....	60
3.1.4	<i>Primary Scientific Observations</i> .....	60
3.1.4.1	Asteroid Mode .....	60
3.1.5	<i>MIRO Flight Computer Memory Operations</i> .....	61
3.1.6	<i>Thermal Operating Limits</i> .....	61
3.1.7	<i>Optimizing Data Taking</i> .....	61
3.1.7.1	Calibration Heater.....	61
3.1.7.2	CTS Gap.....	62
3.1.7.3	Housekeeping Cycle Skip .....	62
3.2	OPERATING MODES.....	62
3.2.1	<i>Ground Test Plan</i> .....	62
3.2.2	<i>In-orbit Commissioning Plan (MIRO EID-B, § 6.3.2.2)</i> .....	63
3.2.3	<i>Instrument Checkout</i> .....	63
3.2.4	<i>Flight Operations Plans (MIRO EID-B, § 6.3.2.3)</i> .....	63
3.2.4.1	Launch Phase .....	64
3.2.4.2	Cruise Phases .....	64
3.2.4.3	Mars Gravity Assist .....	64
3.2.4.4	Earth Gravity Assists.....	64
3.2.4.5	Steins Fly-by .....	64
3.2.4.6	Lutetia Fly-by.....	64
3.2.4.7	Deep Space Hibernation Mode (DSHM).....	64
3.2.4.8	Rendezvous Manoeuvre .....	65
3.2.4.9	Comet Drift Phase.....	65
3.2.4.10	Comet Approach Navigation and Manoeuvring.....	65
3.2.4.11	Nucleus Mapping and Close Observation.....	65
3.2.4.12	SSP Delivery and Comet Escort to Perihelion.....	65
3.2.5	<i>Interferences</i> .....	65

3.2.6	<i>Operational Constraints</i> .....	66
3.3	FAILURE DETECTION AND RECOVERY STRATEGY .....	66
<b>4</b>	<b>MODE DESCRIPTIONS</b> .....	<b>68</b>
4.1	ENGINEERING MODE .....	68
4.2	MILLIMETER CONTINUUM MODE .....	68
4.3	SUB-MILLIMETER CONTINUUM MODE .....	68
4.4	DUAL CONTINUUM MODE .....	69
4.5	CTS / SUB-MILLIMETER CONTINUUM MODE .....	69
4.6	CTS / DUAL CONTINUUM MODE .....	69
4.7	MODE TRANSITIONS .....	69
4.8	DATA RATES WITHIN MODES .....	70
4.8.1	<i>CTS Dual Continuum Mode</i> .....	71
4.8.2	<i>CTS/SMM Continuum Mode</i> .....	74
4.8.3	<i>Dual Continuum Mode</i> .....	77
4.8.4	<i>SMM Continuum Mode</i> .....	77
4.8.5	<i>MM Continuum Mode</i> .....	78
4.8.6	<i>Engineering Mode</i> .....	78
<b>5</b>	<b>CONTINGENCY RECOVERY AND FLIGHT CONTROL PROCEDURES / SEQUENCES</b> .....	<b>79</b>
<b>6</b>	<b>DATA OPERATIONS HANDBOOK (TELECOMMANDS)</b> .....	<b>81</b>
6.1	TELECOMMANDS .....	81
6.1.1	<i>Warm Up Telecommands</i> .....	81
6.1.1.1	Calibration Heater Telecommand .....	81
6.1.1.1.1	Description .....	81
6.1.1.1.2	Packet Definition .....	82
6.1.1.1.3	Parameters .....	82
6.1.1.1.4	Execution Description .....	82
6.1.1.1.4.1	Action Taken .....	82
6.1.1.1.4.2	Resulting Effect .....	82
6.1.1.1.4.3	Additional Information .....	83
6.1.1.1.5	RSDB Inputs .....	83
6.1.1.2	USO Power Telecommand .....	84
6.1.1.2.1	Description .....	84
6.1.1.2.2	Packet Definition .....	84
6.1.1.2.3	Parameters .....	84
6.1.1.2.4	Execution Description .....	84
6.1.1.2.4.1	Action Taken .....	84
6.1.1.2.4.2	Resulting Effect .....	85
6.1.1.2.4.3	Additional Information .....	85
6.1.1.2.5	RSDB Inputs .....	85
6.1.1.3	CTS Warm Up Telecommand .....	86
6.1.1.3.1	Description .....	86
6.1.1.3.2	Packet Definition .....	86
6.1.1.3.3	Parameters .....	87
6.1.1.3.4	Execution Description .....	87
6.1.1.3.4.1	Action Taken .....	87
6.1.1.3.4.2	Resulting Effect .....	87
6.1.1.3.4.3	Additional Information .....	88
6.1.1.3.5	RSDB Inputs .....	89
6.1.2	<i>Mode Change Telecommands</i> .....	90
6.1.2.1	Mode Change Telecommand .....	90
6.1.2.1.1	Description .....	90
6.1.2.1.2	Packet Definition .....	91
6.1.2.1.3	Parameters .....	92

6.1.2.1.4	Execution Description.....	92
6.1.2.1.4.1	Action Taken .....	92
6.1.2.1.4.2	Resulting Effect .....	93
6.1.2.1.4.3	Additional Information .....	95
6.1.2.1.5	RSDB Inputs.....	96
6.1.2.2	Asteroid Mode Telecommand.....	97
6.1.2.2.1	Description .....	97
6.1.2.2.2	Packet Definition.....	99
6.1.2.2.3	Parameters .....	99
6.1.2.2.4	Execution Description.....	100
6.1.2.2.4.1	Action Taken .....	100
6.1.2.2.4.2	Resulting Effect .....	100
6.1.2.2.4.3	Additional Information .....	101
6.1.2.2.5	RSDB Inputs.....	101
6.1.3	<i>Additional Engineering Mode Telecommands</i> .....	102
6.1.3.1	Engineering Housekeeping Cycle Skip Telecommand .....	102
6.1.3.1.1	Description .....	102
6.1.3.1.2	Packet Definition.....	102
6.1.3.1.3	Parameters .....	102
6.1.3.1.4	Execution Description.....	103
6.1.3.1.4.1	Action Taken .....	103
6.1.3.1.4.2	Resulting Effect .....	103
6.1.3.1.4.3	Additional Information .....	103
6.1.3.1.5	RSDB Inputs.....	104
6.1.4	<i>Additional Continuum Mode Telecommands</i> .....	105
6.1.4.1	Continuum Subtraction Value Telecommand .....	105
6.1.4.1.1	Description .....	105
6.1.4.1.2	Packet Definition.....	105
6.1.4.1.3	Parameters .....	106
6.1.4.1.4	Execution Description.....	106
6.1.4.1.4.1	Action Taken .....	106
6.1.4.1.4.2	Resulting Effect .....	106
6.1.4.1.4.3	Additional Information .....	106
6.1.4.1.5	RSDB Inputs.....	107
6.1.4.2	Millimeter LNA Power Telecommand.....	108
6.1.4.2.1	Description .....	108
6.1.4.2.2	Packet Definition.....	108
6.1.4.2.3	Parameters .....	108
6.1.4.2.4	Execution Description.....	108
6.1.4.2.4.1	Action Taken .....	109
6.1.4.2.4.2	Resulting Effect .....	109
6.1.4.2.4.3	Additional Information .....	109
6.1.4.2.5	RSDB Inputs.....	109
6.1.4.3	Submillimeter LNA Power Telecommand Definition .....	110
6.1.4.3.1	Description .....	110
6.1.4.3.2	Packet Definition.....	110
6.1.4.3.3	Parameters .....	110
6.1.4.3.3.1	Action Taken .....	110
6.1.4.3.3.2	Resulting Effect .....	111
6.1.4.3.3.3	Additional Information .....	111
6.1.4.3.5	RSDB Inputs.....	111
6.1.5	<i>Additional Spectroscopic Mode Telecommands</i> .....	112
6.1.5.1	IFP Power Control Telecommand .....	112
6.1.5.1.1	Description .....	112
6.1.5.1.2	Packet Definition.....	112
6.1.5.1.3	Parameters .....	112
6.1.5.1.4	Execution Description.....	113
6.1.5.1.4.1	Action Taken .....	113
6.1.5.1.4.2	Resulting Effect .....	113

---

6.1.5.1.4.3	Additional Information .....	114
6.1.5.1.5	RSDB Inputs.....	114
6.1.5.2	Submillimeter Gunn Voltage Telecommand .....	115
6.1.5.2.1	Description .....	115
6.1.5.2.2	Packet Definitions .....	115
6.1.5.2.3	Parameters .....	115
6.1.5.2.4	Execution Description.....	116
6.1.5.2.4.1	Action Taken .....	116
6.1.5.2.4.2	Resulting Effect.....	116
6.1.5.2.4.3	Additional Information .....	118
6.1.5.2.5	RSDB Entries .....	119
6.1.5.3	PLL Reset Telecommand .....	120
6.1.5.3.1	Description .....	120
6.1.5.3.2	Packet Definition.....	120
6.1.5.3.3	Parameters .....	120
6.1.5.3.4	Execution Description.....	120
6.1.5.3.4.1	Action Taken .....	120
6.1.5.3.4.2	Resulting Effect.....	121
6.1.5.3.4.3	Additional Information .....	121
6.1.5.3.5	RSDB Inputs.....	121
6.1.5.4	SMM Gunn Voltage Auto-control Enable/Disable Telecommand .....	122
6.1.5.4.1	Description .....	122
6.1.5.4.2	Packet Definition.....	122
6.1.5.4.3	Parameters .....	122
6.1.5.4.4	Execution Description.....	122
6.1.5.4.4.1	Action Taken .....	122
6.1.5.4.4.2	Resulting Effect.....	123
6.1.5.4.4.3	Additional Information .....	124
6.1.5.4.5	RSDB Inputs.....	124
6.1.5.5	CTS Heater Control Telecommand .....	125
6.1.5.5.1	Description .....	125
6.1.5.5.2	Packet Definition.....	125
6.1.5.5.3	Parameters .....	126
6.1.5.5.4	Execution Description.....	126
6.1.5.5.4.1	Action Taken .....	126
6.1.5.5.4.2	Resulting Effect.....	126
6.1.5.5.4.3	Additional Information .....	127
6.1.5.5.5	RSDB Inputs.....	127
6.1.5.6	CTS Internal Calibration Telecommand .....	128
6.1.5.6.1	Description .....	128
6.1.5.6.2	Packet Definition.....	128
6.1.5.6.3	Parameters .....	129
6.1.5.6.4	Execution Description.....	129
6.1.5.6.4.1	Action Taken .....	129
6.1.5.6.4.2	Resulting Effect.....	131
6.1.5.6.4.3	Additional Information .....	131
6.1.5.6.5	RSDB Inputs.....	132
6.1.5.7	CTS Data Masks Telecommand .....	133
6.1.5.7.1	Description .....	133
6.1.5.7.2	Packet Definition.....	133
6.1.5.7.3	Parameters .....	134
6.1.5.7.4	Execution Description.....	134
6.1.5.7.4.1	Action Taken .....	135
6.1.5.7.4.2	Resulting Effect.....	135
6.1.5.7.4.3	Additional Information .....	135
6.1.5.7.5	RSDB Inputs.....	135
6.1.5.8	CTS Run Time Telecommand .....	138
6.1.5.8.1	Description .....	138
6.1.5.8.2	Packet Definition.....	139

6.1.5.8.3	Parameters .....	139
6.1.5.8.4	Execution Description.....	140
6.1.5.8.4.1	Action Taken .....	140
6.1.5.8.4.2	Resulting Effect .....	140
6.1.5.8.4.3	Additional Information .....	141
6.1.5.8.5	RSDB Inputs.....	142
6.1.5.9	CTS Pulse Position Telecommand .....	143
6.1.5.9.1	Description .....	143
6.1.5.9.2	Packet Definition.....	143
6.1.5.9.3	Parameters .....	143
6.1.5.9.4	Execution Description.....	143
6.1.5.9.4.1	Action Taken .....	144
6.1.5.9.4.2	Resulting Effect .....	144
6.1.5.9.4.3	Additional Information .....	144
6.1.5.9.5	RSDB Inputs.....	144
6.1.6	<i>Calibration Mirror Control Telecommands</i> .....	145
6.1.6.1	Move Mirror Telecommand .....	145
6.1.6.1.1	Description .....	145
6.1.6.1.2	Packet Definition.....	145
6.1.6.1.3	Parameters .....	145
6.1.6.1.4	Execution Description.....	145
6.1.6.1.4.1	Action Taken .....	145
6.1.6.1.4.2	Resulting Effect .....	146
6.1.6.1.4.3	Additional Information .....	147
6.1.6.1.5	RSDB Inputs.....	147
6.1.6.2	Step Mirror Telecommand .....	148
6.1.6.2.1	Description .....	148
6.1.6.2.2	Packet Definition.....	148
6.1.6.2.3	Parameters .....	149
6.1.6.2.4	Execution Description.....	149
6.1.6.2.4.1	Action Taken .....	149
6.1.6.2.4.2	Resulting Effect .....	149
6.1.6.2.4.3	Additional Information .....	149
6.1.6.2.5	RSDB Inputs.....	150
6.1.7	<i>Software Telecommands</i> .....	151
6.1.7.1	Software Restart Telecommand .....	151
6.1.7.1.1	Description .....	151
6.1.7.1.2	Packet Definition.....	151
6.1.7.1.3	Parameters .....	151
6.1.7.1.4	Execution Description.....	151
6.1.7.1.4.1	Action Taken .....	152
6.1.7.1.4.2	Resulting Effect .....	152
6.1.7.1.4.3	Additional Information .....	152
6.1.7.1.5	RSDB Inputs.....	152
6.1.7.2	Memory Checksum Telecommand .....	153
6.1.7.2.1	Description .....	153
6.1.7.2.2	Packet Definition.....	153
6.1.7.2.3	Parameters .....	153
6.1.7.2.4	Execution Description.....	154
6.1.7.2.4.1	Action Taken .....	154
6.1.7.2.4.2	Resulting Effect .....	154
6.1.7.2.4.3	Additional Information .....	154
6.1.7.2.5	RSDB Inputs.....	155
6.1.7.3	Memory Dump Telecommand .....	156
6.1.7.3.1	Description .....	156
6.1.7.3.2	Packet Definition.....	156
6.1.7.3.3	Parameters .....	156
6.1.7.3.4	Execution Description.....	157
6.1.7.3.4.1	Action Taken .....	157



---

6.1.7.3.4.2	Resulting Effect .....	157
6.1.7.3.4.3	Additional Information .....	157
6.1.7.3.5	RSDB Inputs .....	158
6.1.7.4	Memory Load Telecommand .....	159
6.1.7.4.1	Description .....	159
6.1.7.4.2	Packet Definition .....	159
6.1.7.4.3	Parameters .....	160
6.1.7.4.4	Execution Description .....	160
6.1.7.4.4.1	Action Taken .....	160
6.1.7.4.4.2	Resulting Effect .....	160
6.1.7.4.4.3	Additional Information .....	160
6.1.7.4.5	RSDB Inputs .....	161
6.1.8	<i>S/C Interface Telecommands</i> .....	162
6.1.8.1	Enable MIRO HK Generation Telecommand .....	162
6.1.8.1.1	Description .....	162
6.1.8.1.2	Packet Definition .....	162
6.1.8.1.3	Parameters .....	162
6.1.8.1.4	Execution Description .....	162
6.1.8.1.4.1	Action Taken .....	162
6.1.8.1.4.2	Resulting Effect .....	163
6.1.8.1.5	RSDB Inputs .....	163
6.1.8.2	Disable MIRO HK Generation Telecommand .....	164
6.1.8.2.1	Description .....	164
6.1.8.2.2	Packet Definition .....	164
6.1.8.2.3	Parameters .....	164
6.1.8.2.4	Execution Description .....	164
6.1.8.2.4.1	Action Taken .....	164
6.1.8.2.4.2	Resulting Effect .....	165
6.1.8.2.5	RSDB Inputs .....	165
6.1.8.3	Time Update Telecommand .....	166
6.1.8.3.1	Description .....	166
6.1.8.3.2	Packet Definition .....	166
6.1.8.3.3	Parameters .....	166
6.1.8.3.4	Execution Description .....	166
6.1.8.3.4.1	Actions Taken .....	166
6.1.8.3.4.2	Resulting Effects .....	166
6.1.8.3.4.3	Additional Information .....	167
6.1.8.3.5	RSDB Inputs .....	167
6.1.8.4	Connection Test Telecommand .....	168
6.1.8.4.1	Description .....	168
6.1.8.4.2	Packet Definition .....	168
6.1.8.4.3	Parameters .....	168
6.1.8.4.4	Execution Description .....	168
6.1.8.4.4.1	Actions Taken .....	168
6.1.8.4.4.2	Resulting Effects .....	169
6.1.8.4.5	RSDB Inputs .....	169
6.1.8.5	Enable Science Telecommand .....	170
6.1.8.5.1	Description .....	170
6.1.8.5.2	Packet Definition .....	170
6.1.8.5.3	Parameters .....	170
6.1.8.5.4	Execution Description .....	170
6.1.8.5.4.1	Actions Taken .....	170
6.1.8.5.4.2	Resulting Effects .....	171
6.1.8.5.5	RSDB Inputs .....	171
6.1.8.6	Disable Science Telecommand .....	172
6.1.8.6.1	Description .....	172
6.1.8.6.2	Packet Definition .....	172
6.1.8.6.3	Parameters .....	172
6.1.8.6.4	Execution Description .....	172

6.1.8.6.4.1	Actions Taken .....	173
6.1.8.6.4.2	Resulting Effects .....	173
6.1.8.6.5	RSDB Inputs .....	173
6.1.8.7	Reset Telemetry Telecommand .....	174
6.1.8.7.1	Description .....	174
6.1.8.7.2	Packet Definition .....	174
6.1.8.7.3	Parameters .....	174
6.1.8.7.4	Execution Description .....	174
6.1.8.7.4.1	Actions Taken .....	174
6.1.8.7.4.2	Resulting Effects .....	174
6.1.8.7.5	RSDB Inputs .....	175
<b>7</b>	<b>DATA OPERATIONS HANDBOOK (TELEMETRY) .....</b>	<b>176</b>
7.1	TELEMETRY .....	176
7.1.1	Introduction .....	176
7.1.2	Housekeeping Data Telemetry .....	177
7.1.2.1	Description .....	177
7.1.2.2	Packet Definition .....	177
7.1.2.3	Expected Values .....	181
7.1.2.4	Calibration .....	206
7.1.2.4.1	Temperature Calibration .....	206
7.1.2.4.2	Voltage Calibration .....	207
7.1.2.4.3	Current Calibration .....	208
7.1.2.4.4	Other Calibration .....	208
7.1.2.5	Limits .....	209
7.1.2.6	RSDB Entries .....	210
7.1.3	Spectroscopic (CTS) Science Telemetry .....	211
7.1.3.1	Description .....	211
7.1.3.2	Packet Definition .....	212
7.1.3.3	Expected Values .....	214
7.1.3.4	Calibration .....	216
7.1.3.5	RSDB Entries .....	217
7.1.4	Submillimeter Continuum Science Telemetry .....	218
7.1.4.1	Description .....	218
7.1.4.2	Packet Telemetry Definition .....	219
7.1.4.3	Expected Value .....	220
7.1.4.4	Calibration .....	221
7.1.4.5	RSDB Entries .....	221
7.1.5	Millimeter Continuum Science Telemetry .....	222
7.1.5.1	Description .....	222
7.1.5.2	Packet Telemetry Definition .....	223
7.1.5.3	Expected Values .....	224
7.1.5.4	Calibration .....	225
7.1.5.5	RSDB Entries .....	225
7.1.6	Miscellaneous Science Telemetry .....	226
7.1.6.1	Description .....	226
7.1.6.2	Packet Definition .....	226
7.1.6.3	Expected Value .....	228
7.1.6.4	RSDB Entries .....	228
7.1.7	Memory Dump Telemetry .....	229
7.1.7.1	Description .....	229
7.1.7.2	Packet Definition .....	229
7.1.7.3	Expected Value .....	230
7.1.7.4	RSDB Entries .....	230
7.1.8	Memory Checksum Telemetry .....	231
7.1.8.1	Description .....	231
7.1.8.2	Packet Definition .....	231
7.1.8.3	Expected Value .....	232

7.1.8.4	RSDB Entries.....	233
7.1.9	<i>MIRO On (Progress Event Report #1) Telemetry</i> .....	234
7.1.9.1	Description .....	234
7.1.9.2	Packet Definition .....	234
7.1.9.3	Expected Value .....	235
7.1.9.4	RSDB Entries.....	235
7.1.10	<i>Asteroid Mode Started (Progress Event Report #2) Telemetry</i> .....	236
7.1.10.1	Description .....	236
7.1.10.2	Packet Definition .....	236
7.1.10.3	Expected Value .....	237
7.1.10.4	RSDB Entries.....	237
7.1.11	<i>Asteroid Mode Completed (Progress Event Report #3) Telemetry</i> .....	238
7.1.11.1	Description .....	238
7.1.11.2	Packet Definition .....	238
7.1.11.3	Expected Value .....	239
7.1.11.4	RSDB Entries.....	239
7.1.12	<i>Connection Report Telemetry</i> .....	240
7.1.12.1	Description .....	240
7.1.12.2	Telemetry Definition .....	240
7.1.12.3	Expected value .....	241
7.1.12.4	RSDB Entries.....	241
7.1.13	<i>Mirror Error Report Type 1 Telemetry</i> .....	242
7.1.13.1	Description .....	242
7.1.13.2	Packet Definition .....	242
7.1.13.3	Expected Values .....	243
7.1.13.4	RSDB Entries.....	243
7.1.14	<i>Mirror Error Report Type 2 Telemetry</i> .....	244
7.1.14.1	Description .....	244
7.1.14.2	Packet Definition .....	244
7.1.14.3	Expected Value .....	245
7.1.14.4	RSDB Entries.....	245
7.1.15	<i>Mirror Error Report Type 3 Telemetry</i> .....	246
7.1.15.1	Description .....	246
7.1.15.2	Packet Definition .....	246
7.1.15.3	Expected Value .....	247
7.1.15.4	RSDB Entries.....	247
7.1.16	<i>Mirror Error Report Type 4 Telemetry</i> .....	248
7.1.16.1	Description .....	248
7.1.16.2	Packet Definition .....	248
7.1.16.3	Expected Value .....	249
7.1.16.4	RSDB Entries.....	249
7.1.17	<i>Mirror Error Report Type 5 Telemetry</i> .....	250
7.1.17.1	Description .....	250
7.1.17.2	Packet Definition .....	250
7.1.17.3	Expected Value .....	251
7.1.17.4	RSDB Entries.....	251
7.1.18	<i>CTS Error Report Telemetry</i> .....	252
7.1.18.1	Description .....	252
7.1.18.2	Packet Definition .....	252
7.1.18.3	Expected Value .....	253
7.1.18.4	RSDB Entries.....	253
7.1.19	<i>Accept Success Event Report Telemetry</i> .....	254
7.1.19.1	Description .....	254
7.1.19.2	Packet Definition .....	254
7.1.19.3	Expected Value .....	255
7.1.19.4	RSDB Entries.....	255
7.1.20	<i>Incomplete Packet Event Report Telemetry</i> .....	256
7.1.20.1	Description .....	256

7.1.20.2	Packet Definition .....	256
7.1.20.3	Expected values .....	257
7.1.20.4	RSDB Entries.....	257
<i>7.1.21</i>	<i>Incorrect Checksum Event Report Telemetry.....</i>	<i>258</i>
7.1.21.1	Description .....	258
7.1.21.2	Packet Definition .....	258
7.1.21.3	Expected Values .....	259
7.1.21.4	RSDB Entries.....	259
<i>7.1.22</i>	<i>Incorrect APID Event Report Telemetry.....</i>	<i>260</i>
7.1.22.1	Description .....	260
7.1.22.2	Packet Definition .....	260
7.1.22.3	Expected Values .....	261
7.1.22.4	RSDB Entries.....	261
<i>7.1.23</i>	<i>Invalid Command Code Event Report Telemetry Definition.....</i>	<i>262</i>
7.1.23.1	Description .....	262
7.1.23.2	Packet Definition .....	262
7.1.23.3	Expected Value .....	262
7.1.23.4	RSDB Inputs .....	263
<i>7.1.24</i>	<i>Additional Rosetta Telemetry Relevant to MIRO.....</i>	<i>264</i>

---

## List of Tables

1.1.1-1	The MIRO submillimeter receiver is fixed tuned to observe simultaneously the eight molecular transitions shown in this table. ....	16
1.1.2-1	Relationship to Stated Goals of Rosetta Mission .....	18
1.2.1.1-1	MIRO Instrument Performance Characteristics .....	21
1.2.2.4-1	IF frequencies for the submillimeter-wave receiver. Mixer numbers refer to numbers given in Figure 1.2-4 .....	28
2.3.1-1	Power Supply Interface .....	37
2.3.1-2	MIRO Power Consumption by Mode .....	39
2.3.1-3	Comments on the power options shown in Table 2.3.1-2.....	40
2.5.1-1	Measured mass of the MIRO instrument in kilograms .....	50
2.9-1	Experiment OBDH Interface Channels/Functions .....	52
3.1.3-1	MIRO Calibration/Observing Needs .....	59
3.1.3-2	Calibration Priorities (1 = highest) .....	60
3.3-1	MIRO Failure Modes and Possible Recovery Operations .....	67

---

## List of Figures

1.2-2	MIRO Instrument Block Diagram .....	22
1.2-3	Schematic diagram of the millimeter-wave receiver front end.....	25
1.2-4	Schematic diagram of the submillimeter wave receiver front end .....	26
1.2-5	Schematic diagram of the submillimeter wave receiver intermediate frequency processor .....	27
1.2-6	Chirp transform spectrometer configuration.....	29
2.1-1	Electronics Unit .....	32
2.1-2	Sensor Unit.....	33
2.1-3	Sensor Backend Electronics Unit .....	34
2.1-4	Ultra Stable Oscillator .....	35
2.2-1	Calibration Switch Mechanism.....	36
2.3.1-1	Power Distribution Block Diagram (Electronics Unit).....	38
2.3.1-2	Power Distribution Block Diagram (Sensor Backend Electronics Unit).....	38
2.4.1-1	MIRO Software Data Flow and Control Diagram.....	42
2.4.3-1	MIRO Hardware Data and Control Flow.....	44
2.5.2-1	MIRO Instrument Operating Power (in watts) .....	51
2.9.7-1	Telemetry Interface Circuit—Data Output and Sample Input.....	54
2.9.7-2	Telecommand Interface Circuit—Data Input, Clock Input (combined with TM) and Sample Input .....	55
2.9.7-3	Broadcast Pulse (TSY) Circuit Interface.....	56

# 1 OVERVIEW

## 1.1 SCIENTIFIC OBJECTIVES

### 1.1.1 INTRODUCTION

The investigation, **Microwave Instrument for the Rosetta Orbiter (MIRO)**, addresses the nature of the cometary nucleus, outgassing from the nucleus and development of the coma as strongly interrelated aspects of cometary physics, and searches for outgassing activity on asteroids. MIRO is configured both as a continuum and a very high spectral resolution line receiver. Center-band operating frequencies are near 188 GHz (1.6 mm) and 562 GHz (0.5 mm). Spatial resolution of the instrument at 562 GHz is approximately 5 m at a distance of 2 km from the nucleus; spectral resolution is sufficient to observe individual, thermally broadened, line shapes at all temperatures down to 10 K or less. Four key volatile species—H<sub>2</sub>O, CO, CH<sub>3</sub>OH, and NH<sub>3</sub>—and the isotopes—H<sub>2</sub><sup>17</sup>O and H<sub>2</sub><sup>18</sup>O—are pre-programmed for observation. These lines are listed in Table 1.1.1-1. The primary retrieved products are abundance, velocity, and temperature of each species, along with their spatial and temporal variability. This information will be used to infer coma structure and processes, including the nature of the nucleus/coma interface.

MIRO will sense the subsurface temperature of the nucleus to depths of several centimeters or more using the continuum channels at millimeter and submillimeter wavelengths. Model studies will relate these measurements to electrical and thermal properties of the nucleus and address issues connected to the sublimation of ices, ice and dust mantle thickness, and the formation of gas and dust jets. The global nature of these measurements will allow in situ lander data to be extrapolated globally, while the long duration of the mission will allow us to follow the time variability of surface temperatures and gas production. Models of the thermal emission from comets are very crude at this time since they are only loosely constrained by data. MIRO will offer the first opportunity to gather subsurface temperature data that can be used to test thermal models. MIRO is highly complementary to the IR mapping instrument on the orbiter, having similar spatial resolution but greater depth penetration.

**Table 1.1.1-1: The MIRO submillimeter receiver is fixed tuned to observe simultaneously the eight molecular transitions shown in this table.**

Species	Frequency (MHz)	Transition
Water H <sub>2</sub> <sup>16</sup> O	556936.002	1(1,0)-1(0,1)
H <sub>2</sub> <sup>17</sup> O	552020.960	1(1,0)-1(0,1)
H <sub>2</sub> <sup>18</sup> O	547676.440	1(1,0)-1(0,1)
Carbon Monoxide CO	576267.9305	J(5-4)
Ammonia NH <sub>3</sub>	572498.3784	J(1-0)
Methanol CH <sub>3</sub> OH	553146.296	8 (1)--7 (0) E
CH <sub>3</sub> OH	568566.054	3 (-2)--2 (-1) E
CH <sub>3</sub> OH	579151.005	12 (-1)--11(-1) E

**1.1.2****SCIENCE OBJECTIVES AND INVESTIGATION**

The measurement objectives of the MIRO investigation are listed below.

**1. Characterise abundances of key volatile species and isotope ratios**

The MIRO instrument will measure absolute abundances of key volatile species—H<sub>2</sub>O, CO, CH<sub>3</sub>OH, and NH<sub>3</sub>—and quantify fundamental isotope ratios—<sup>17</sup>O/<sup>16</sup>O and <sup>18</sup>O/<sup>16</sup>O—in a region within several km from the surface of the nucleus, nearly independent of the orbiter to comet nucleus distance.

Water and carbon monoxide are chosen for observation because they are believed to be the primary ices driving cometary activity. Methanol is a common organic molecule, chosen because it is a convenient probe of gas excitation temperature by virtue of its many transitions. Knowledge of ammonia abundance has important implications for the excitation state of nitrogen in the solar nebula. By providing measurements of isotopic species abundances with extremely high mass discrimination, the MIRO experiment can use isotope ratios as a discriminator of cometary origins. The MIRO investigation will combine measurements of the variation of outgassing rates with heliocentric distance with models of gas volatilisation and transport in the nucleus to quantify the intrinsic abundances of volatiles within the nucleus.

**2. Understand processes controlling outgassing in upper surface layers of the nucleus**

The MIRO experiment will measure surface outgassing rates for H<sub>2</sub>O, CO, and other volatile species, as well as nucleus subsurface temperatures to study key processes controlling the outgassing of the comet nucleus. Correlated measurements of outgassing rates and nucleus thermal properties will be used to



test models of gas formation, transport, and escape from the nucleus to advance our understanding of the important processes leading to nucleus devolatilisation.

### **3. Study the processes controlling the development of the inner coma**

MIRO will measure density, temperature, and kinematic velocity in the transition region close to the surface of the nucleus. Measurements of gas density, temperature, and flow field in the coma near the surface of the nucleus will be used to test models of the important radiative and dynamical processes in the inner coma, and thus improve our understanding of the causes of observed gas and dust structures. The high spectral and spatial resolution provided by the MIRO instrument will provide a unique capability to observe narrow Doppler-broadened spectral lines resulting from the low gas temperatures and low pressures. Asymmetric line shapes due to Doppler shifts of the evaporating and effusing gases in the line of sight to the comet nucleus will be searched for to understand the boundary layer at the nucleus.

### **4. Characterise the nucleus subsurface to depths of few centimeters or more**

The MIRO instrument will map the nucleus and determine the subsurface temperature distribution to depths of several centimeters or more. Morphological features on scales as small as 5 m will be identified and correlated with regions of outgassing. The combination of global outgassing and temperature observations from MIRO and in situ measurements from the Rosetta lander will provide important insights into the origins of outgassing regions and of the thermal inertia of subsurface materials in the nucleus.

### **5. Search for low levels of gas in the asteroid environment**

The MIRO instrument will measure subsurface temperatures and search for low levels of water vapor (and other constituent gases) in the vicinity of asteroids (2867) Steins and (21) Lutetia, to provide information on near surface thermal characteristics including the presence or absence of a regolith or water ice.

### **6. Search for high altitude water vapor in the atmosphere of Mars**

The MIRO instrument has the potential for providing unique data about the upper atmosphere of Mars during the Rosetta encounter with the planet in February 2007. No other instrument with the capabilities of MIRO has been on a spacecraft in the vicinity of Mars. Its very high-resolution spectrometer makes it sensitive for measuring high altitude water concentration and winds. Its two continuum channels will provide surface and sub-surface temperatures. Carbon monoxide and several isotopes of water can also be measured or upper limits set.

The relationships between MIRO objectives and those identified in ESA SCI(93)7 are given in Table 1.1.2-1.

**Table 1.1.2-1: Relationship to Stated Goals of Rosetta Mission**

To Achieve Rosetta Objectives	MIRO Will	Corresponding MIRO Objectives
Global characterisation of nucleus, surface morphology and composition, and dynamic properties	<ul style="list-style-type: none"> <li>• Perform global temperature mapping (maximum ground resolution &lt;5m)</li> <li>• Dayside and nightside</li> <li>• Derive thermo-physical properties of subsurface</li> <li>• Detect and characterise active/inactive regions using temperature and spectroscopic detection of H<sub>2</sub>O, CO, and NH<sub>3</sub></li> <li>• Confirm state of rotation</li> </ul>	Globally characterise the nucleus subsurface to depths of a few centimeters or more
Chemical, mineralogical, and isotopic composition of volatiles and refractories in cometary nucleus	<ul style="list-style-type: none"> <li>• Measure abundances and isotopic ratios of important coma gases (H<sub>2</sub>O, NH<sub>3</sub>, CO, CH<sub>3</sub>OH)</li> </ul>	Characterise the abundances of major volatile species and key isotope ratios in volatiles
Physical properties and interrelation of volatiles and refractories in cometary nucleus	<ul style="list-style-type: none"> <li>• Measure gas temperature and molecular excitation (CH<sub>3</sub>OH) in near surface coma</li> <li>• Measure flow velocities</li> </ul>	Study the processes controlling the development of the inner coma  Study the processes controlling outgassing in the surface layer of nucleus
Study of development of cometary activity and the processes in the surface layer of the nucleus and in the inner coma	<ul style="list-style-type: none"> <li>• Measure onset outgassing of water and carbon dioxide</li> <li>• Measure local origin of outgassing</li> <li>• Measure gas flow velocities</li> </ul>	Study the processes controlling the development of the inner coma  Study the processes controlling outgassing in the surface layer of nucleus
Origin of comets, relationship between cometary and interstellar material, and origin of Solar System	<ul style="list-style-type: none"> <li>• Measure oxygen isotopes to infer temperature of formation</li> <li>• Measure outgassing as function of heliospheric distance</li> </ul>	Study the processes controlling outgassing in the surface of the nucleus  Characterise the abundances of major volatile species and key isotopes ratios in volatiles
Global characteristics of asteroids, dynamic properties, surface morphology, and composition	<ul style="list-style-type: none"> <li>• Measure temperature</li> <li>• Search for low levels of outgassing</li> <li>• Confirm state of rotation</li> </ul>	Search for low levels of gas in the asteroid environment

### 1.1.3 MEASUREMENT APPROACH

The MIRO experiment will acquire both high-resolution molecular line spectra in absorption and emission, and broadband continuum emission data from which gas abundances, velocities, temperatures, and nucleus surface and subsurface temperatures will be derived.

The MIRO instrument is composed of a millimeter wave mixer receiver operating with a center-band frequency of 188 GHz, and a submillimeter heterodyne receiver operating with a center-band frequency of 562 GHz. The two receivers are fixed tuned. The submillimeter wave receiver provides both broad-band continuum and high resolution spectroscopic data, whereas the millimeter wave receiver provides continuum data only.

The submillimeter wave spectroscopic frequencies allow simultaneous observations of six molecules, chosen to achieve four (1,2,3, and 5) of the five MIRO objectives. The six molecules pre-selected are known constituents of comets. The submillimeter wave lines observed include the ground-state rotational transition of water 1(10)-1(01) at 557 GHz, the corresponding lines of two oxygen isotopes of water, and the 572 GHz ground state rotational line of ammonia J(1-0). Since these lines are ground-state transitions (i.e. between the lowest rotational levels of these molecules), they are expected to be the strongest in cometary conditions. The submillimeter spectrometer can also observe the CO J(5-4) line, and three methanol lines.

The millimeter and submillimeter wavelength continuum channels address the MIRO objective number 4. Using the continuum channels, MIRO will sense the subsurface temperature of the nucleus to depths of several centimeters or more. Model studies will relate these measurements to electrical and thermal properties of the nucleus and address issues connected to the sublimation of ices, ice and dust mantle thickness, and the formation of gas and dust jets.

### 1.1.4 MIRO SCIENCE DATA DELIVERABLES

1. Intensity Calibrated Continuum Data at 188 GHz;
2. Intensity Calibrated Continuum Data at 562 GHz;
3. Intensity and Frequency Calibrated Spectral Line Data at 562 GHz;
4. Average brightness temperatures of two asteroids at two frequencies;
5. Brightness temperature (partial) maps of comet nucleus at two frequencies;
6. Brightness temperature versus solar phase observations of the comet nucleus at two frequencies;
7. Calculated abundances for all observed molecules as a function of time and spatial position;
8. Measured Doppler velocities for all observed molecules as function of time and spatial position; and
9. Calculated temperature of the coma from methanol spectral line data.

## 1.2 HARDWARE DESCRIPTION

### 1.2.1 INTRODUCTION

The MIRO instrument provides both very sensitive continuum capability for temperature determination and very high-resolution spectroscopy for observation of molecular species. The instrument consists of two heterodyne radiometers, one at millimeter wavelengths (1.3 mm) and one at submillimeter wavelengths (0.5 mm). The millimeter and the sub-millimeter radiometers have continuum bandwidths of 0.5 GHz and 1.0 GHz, respectively. The high-resolution submillimeter spectrometer has a total bandwidth of 180 MHz and a spectral resolution of 44 kHz (4096 channels). Eight different RF frequency bands are shifted into contiguous frequency bands to feed the 180-MHz spectrometer. This allows simultaneous observations of 8 molecular transitions that span a frequency range of 31.5 GHz.

#### 1.2.1.1 Performance Characteristics

Key MIRO instrument performance characteristics are summarised in Table 1.2.1.1-1.

#### 1.2.1.2 System Overall Configuration

A block diagram of the MIRO instrument is shown in Fig. 1.2-2. The instrument is packaged into four separate units. A description of each unit is provided below.

1. The Sensor Unit consists of the telescope, baseplate, and optical bench. The Sensor Unit is mounted to the spacecraft skin at the baseplate. The telescope, mounted on the baseplate, is outside the spacecraft, while the optical bench, also mounted to the baseplate, is inside the spacecraft. The optical bench carries the millimeter- and submillimeter-wave receiver front ends (RFEs), the calibration mechanism, and the quasi-optics for coupling the telescope to the RFEs.
2. The Sensor Backend Electronics Unit is flush mounted internal to the spacecraft on a louvered radiator. It contains the intermediate frequency processor, the phase lock loop, frequency sources and power conditioning and house keeping electronics.
3. The Electronics Unit is flush mounted internal to the spacecraft on a louvered radiator. It contains the Chirp Transform Spectrometer (CTS), the instrument computer, and the power conditioning circuits.
4. The Ultra-Stable Oscillator (USO) Unit is flush mounted internal to the spacecraft and provides the high accuracy frequency reference for the instrument.

**Table 1.2.1.1-1: MIRO Instrument Performance Characteristics**

Equipment	Property	Millimeter-Wave	Submillimeter-Wave	
Telescope	Primary Diameter	30 cm	30 cm	
	Primary F/D	1	1	
	Edge taper on primary	> 20 dB	>20db	
	Near Sidelobe level	<-30 dB	<-30 dB	
	Angular Resolution	23.8 ± arcmin	7.5±0.25 arcmin	
	Primary surface accuracy	<12 microns	< 12 microns	
	Fraction power in main beam	~ 93%	~93%	
Spectral Performance	RF Frequency Band	186.7–189.7 GHz	547.6–579.2 GHz	
	IF Bandwidth	1–1.5 Ghz	5.5-16.5 GHz	
	Spectral Resolution	N/A	44 kHz	
	Allocated Spectral Range per line	N/A	~ 20 MHz	
	Accuracy	< 1 MHz	10 kHz	
Spectrometer	Center Frequency/Bandwidth	1350/180 MHz		
	Number of channels	4096		
Radiometric Performance	DSB Receiver Noise Temperature	2000 K	~4000 K	
	SSB Spectroscopic Sensitivity (300 KHz, 2 min)	relative	2 Krms	
		absolute	3 Krms	
	Continuum Sensitivity (1 sec):	relative	1 Krms	1 Krms
		absolute	3 Krms	3 Krms
	Data Rates	Continuum Mode	<1 kbps	
Spectroscopic Mode		2 kbps		
On-board Storage		0.2 Gb (one day's data volume, Mode 3, 100% duty cycle, see Table 6.3.1-1)		

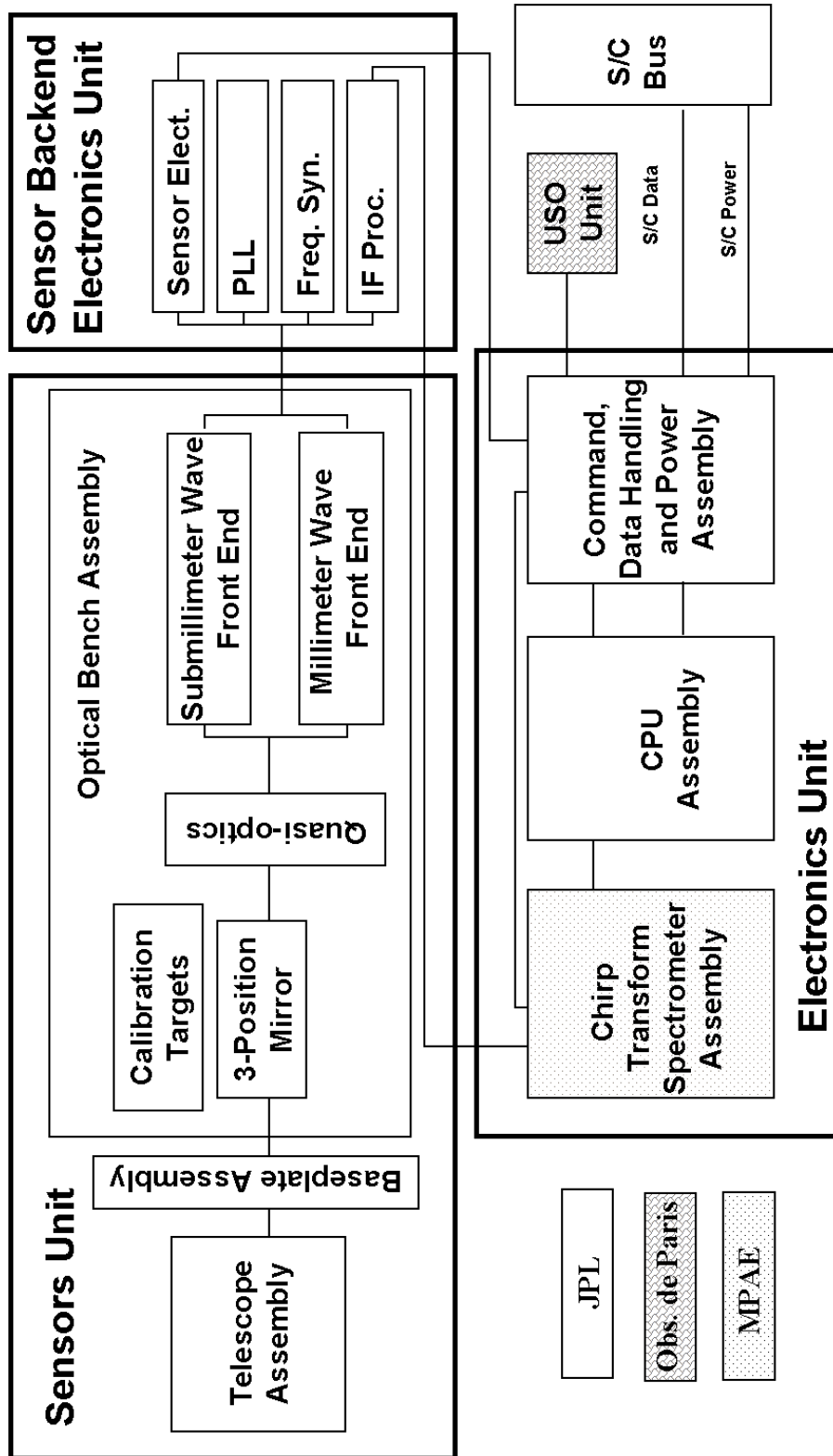

Figure 1.2-2: MIRO Instrument Block Diagram

## 1.2.2 DETAILED DESCRIPTION

### 1.2.2.1 Telescope

The parabolic primary mirror has a diameter of 30 cm, providing a diffraction-limited half-power main beamwidth of about 7.5 arc min at 560 GHz frequency (0.535 mm wavelength) and about 23.8 arc min at 188 GHz (1.6 mm wavelength). An offset Cassegrain design is used to minimise volume and provide very low-level sidelobes. The end-to-end optical system is designed to minimise alignment sensitivity to the large temperature range the telescope will experience during the course of the mission. The Cassegrain design also reduces or eliminates multiple reflections between the receiver input and the secondary mirror, which is a major problem with on-axis systems.

Sets of beam wave-guiding mirrors bring the signals to the feed horns at the receiver front ends (RFEs) on the optical bench, with a minimum amount of loss. The illumination of the primary mirror by millimeter and submillimeter receivers is a Gaussian pattern with >20 dB edge taper resulting in <30 dB sidelobe levels for the primary beam patterns.

A significant advantage of the offset Cassegrain design is the absence of aperture blockage and the resulting improvement in both aperture and beam efficiency. The efficiency of the telescope is also a function of the mirror surface accuracy. The surface RMS is 11  $\mu\text{m}$  corresponding to less than  $\lambda/48$  at 0.535 mm. Combining the effects of the illumination, surface error, and reflectivity losses, the telescope has an aperture efficiency of greater than 0.7 and a main beam efficiency of greater than 0.93 at both frequencies.

The telescope is designed to operate at temperatures between  $\sim 100$  K at comet rendezvous to temperatures near  $\sim 300$  K at perihelion. To maximise performance over this large temperature range, the telescope is fabricated entirely of aluminium so that it scales with temperature to maintain a sharp focus. The beam is nearly parallel at the telescope/optical bench interface minimising misalignment along the optical path. Lateral misalignments are minimised by symmetrical design in one axis and fixing the telescope mount near the beam axis through the baseplate.

### 1.2.2.2 Calibration Targets

Radiometric calibration of the instrument is accomplished using two calibration targets at different temperatures. A permanent-magnet stepper motor switches the RF input to the mm and smm receivers from the telescope to either a cold calibration target or a warm calibration target to provide measurements of the receiver gains. The switching is accomplished by positioning a small mirror in the optical path of the instrument to one of three positions (sky, hot load, cold load). In normal operation, the gain is calibrated every 30 minutes by switching between

hot load, cold load and telescope (sky) positions. Gain calibration is completed in 2 minutes, allowing 28 minutes out of every 30 minutes for observations.

A fail-safe device (pin puller) has been built into the mirror actuator mechanism. In case of a mirror actuator failure, the switching mirror can be moved out of the optical path through the use of a built-in pin puller. In this position, the RF inputs to the receivers arrive from the telescope. A "pulled" pin can be reinserted into the drive mechanism if the failure can be resolved.

The two calibration targets are mounted on the MIRO instrument itself, and each is at a different physical temperature by virtue of its location. The colder of the two targets is mounted outside the spacecraft, exposed to space. It comes to radiative equilibrium under the influence of sunlight, the spacecraft exterior, the MIRO telescope, cold space, and near by objects such as the comet itself. The second target (warm) is mounted inside the spacecraft close to the optical bench. The warm calibration target contains an on-off heater that can be used to increase its temperature above the optical bench temperature. Neither target is temperature controlled, however redundant thermistor sensors provide accurate measurements of the target temperatures.

The calibration targets are constructed from aluminium, machined on one side to form a series of regularly spaced pyramids. The pyramids are coated with an absorber coating material to provide an emissivity greater than 0.99 in both the mm and smm bands.

During spectroscopic observations, the submillimeter wave receiver is operated in a "frequency switched" mode to eliminate residual baseline ripple. For half the integration time, the signal frequency is shifted 5 MHz above the nominal frequency, while the other half of the time it will be shifted 5 MHz below. The frequency is switched every 5 seconds. The on-board computer subtracts the spectra obtained during alternating switch cycles and reports the difference. In normal operation, the difference spectra contains data from three full switch cycles, corresponding to 30 seconds of data. The system, as well as compensate for systematic variations arising from both long- and short-term drifts and from baseline ripple.

### 1.2.2.3 Millimeter-Wave Heterodyne Receiver

The millimeter-wave receiver is a total power, single channel, continuum radiometer. Its operating wavelength is near 1.6-mm. A block diagram of the system is shown in Figure 1.2-3.

The 1.6-mm wave signal is down converted by mixing with a local oscillator (LO) signal at half its frequency in the subharmonic mixer. The resulting intermediate frequency (IF) is filtered and then detected for the total power continuum channel in the Intermediate Frequency Processor (IFP).



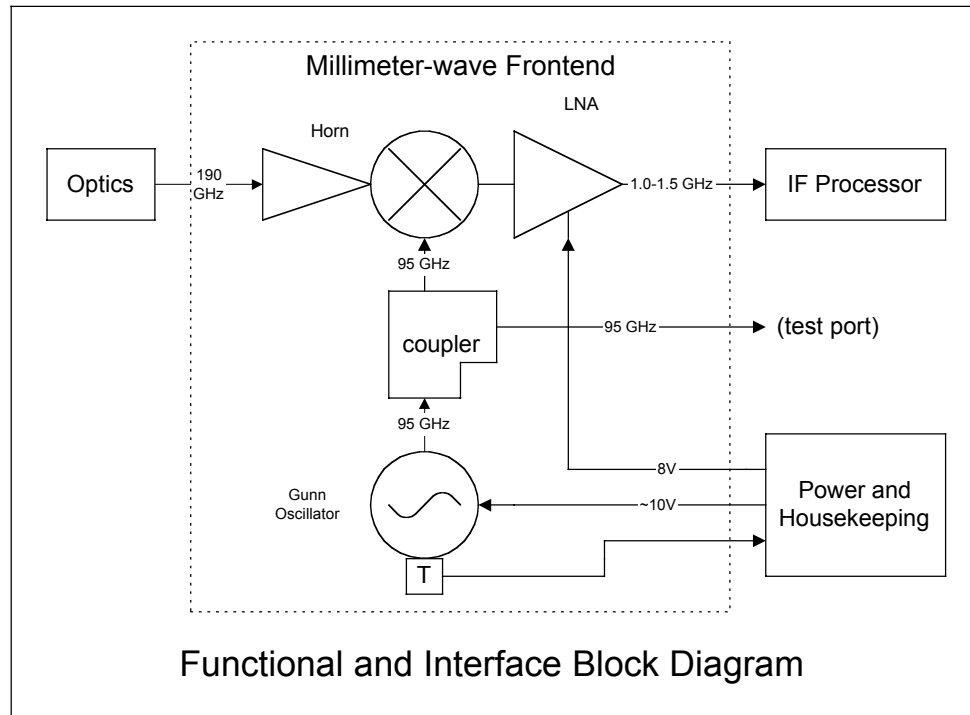
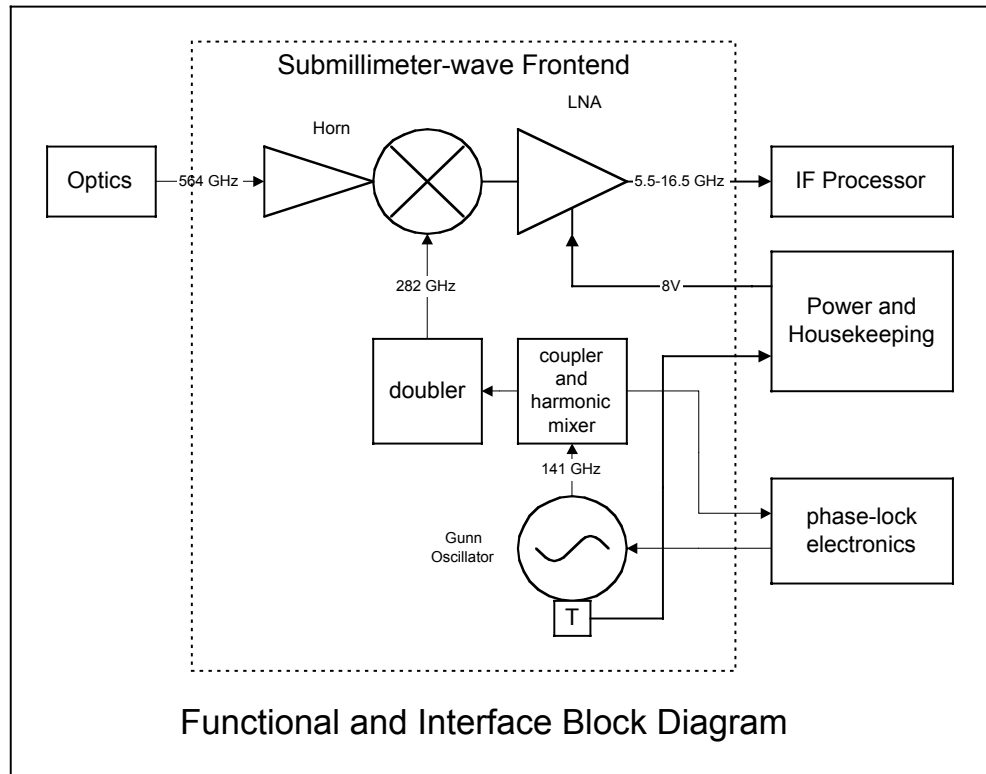

**Figure 1.2-3: Schematic diagram of the millimeter-wave receiver front end**

#### 1.2.2.4 Submillimeter Wave Heterodyne Receiver

The submillimeter-wave receiver operates both as a single broadband radiometer for continuum measurements, and as a spectroscopic receiver. The receiver is fixed tuned to observe three isotopes of water, ( $H_2^{16}O$ ,  $H_2^{17}O$  and  $H_2^{18}O$ ), three methanol lines ( $CH_3OH$ ), ammonia ( $NH_3$ ), and carbon monoxide ( $CO$ ). A block diagram of the submillimeter wave RFE is shown in Figure 1.2-4. A block diagram of the Intermediate Frequency Processor (IFP) is shown in Figure 1.2-5 and Table 1.2.2.4-1 lists the observed lines along with the various frequencies associated with the IFP.

The 0.5-mm wave signal is down converted to a first IF band of 5.5 to 16.5 GHz. A divider separates out the continuum band while the spectroscopic signal is further down converted for input to the spectrometer. Table 1.2.2.4-1 summarises the down converted frequencies for each spectral line of the down converted spectrum for input into the spectrometer. The LO's are used multiple times to save power. Nominally 20 MHz wide filters are used in the IFP before input to the spectrometer to eliminate excess noise. The bandwidth of the spectral line receiver will allow observations over Doppler shifts of  $\pm 5.4$  km/sec or  $\pm 8$  km/sec with frequency switching. This will allow short spectral observations of the asteroids near closest approach, and measurements of low velocity molecular clouds.



**Figure 1.2-4: Schematic diagram of the submillimeter wave receiver front end**

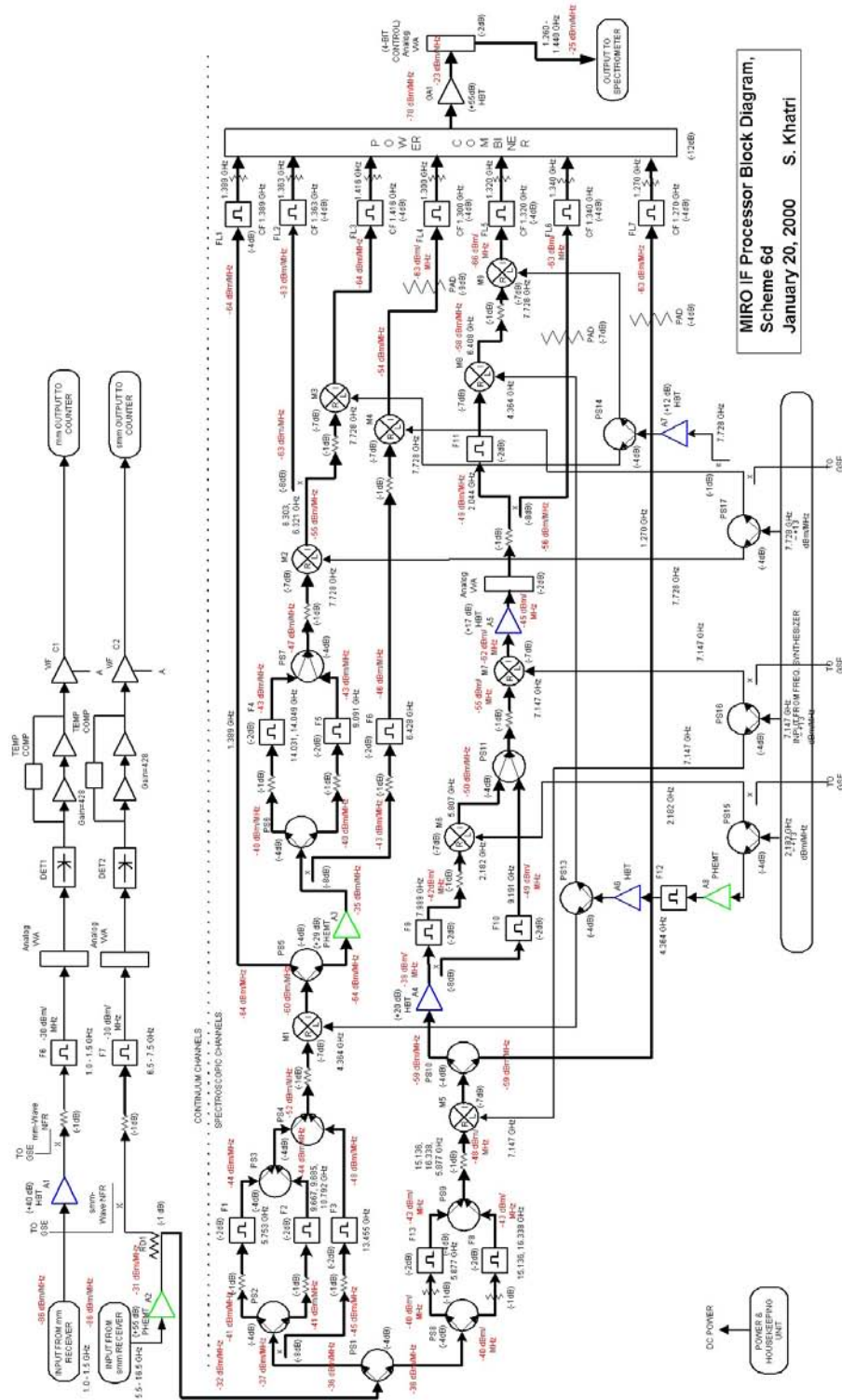

MIRO IF Processor Block Diagram,  
Scheme 6d  
January 20, 2000 S. Khatri

Figure 1.2-5: Schematic diagram of the submillimeter wave receiver intermediate frequency processor

**Table 1.2.2.4-1: IF frequencies for the submillimeter-wave receiver.  
Mixer numbers refer to numbers given in Figure 1.2-4**

		IF 1	IF 2	IF 3	IF 4	IF 5	IF 6	IF 7	IF 8	IF 9	Output
Lines	RF (MHz)		M1 out	M2 out	M3 out	M4 out	M5 out	M6 out	M7 out	M3 out	to
		()	2x2182	7728	7728	7147	2182	7147	2x2182	7728	CTS
H <sub>2</sub> <sup>18</sup> O	547677	15136	-	-	-	-	7989	5807	1340	-	1340
H <sub>2</sub> <sup>17</sup> O	552021	10792	6428	-	-	1300	-	-	-	-	1300
CH <sub>3</sub> OH	553146	9667	14031	6303	1425	-	-	-	-	-	1425
H <sub>2</sub> <sup>16</sup> O	556936	5877	-	-	-	1270	-	-	-	-	1270
CH <sub>3</sub> OH	568566	5753	1389	-	-	-	-	-	-	-	1389
NH <sub>3</sub>	572498	9685	14049	6321	1407	-	-	-	-	-	1407
CO	576268	13455	9091	1363	-	-	-	-	-	-	1363
CH <sub>3</sub> OH	579151	16338	-	-	-	9191	-	2044	6408	1320	1320

### 1.2.2.5 Spectrometer Assembly

The spectrometer is connected to the output of the Intermediate Frequency Processor (IFP) which down converts only the parts of the submillimeter-wave receiver's first IF that are necessary. The spectrometer's function is to perform real-time spectral analysis of the down converted submillimeter-wave signals. The spectrometer output is a digitised power spectrum supplied to the Command and Data Handling System.

The spectrometer is a Chirp Transform Spectrometer having 4096 channels, each channel having a resolution of 44 kHz. The high spectral resolution is needed to observe thermally broadened spectral lines in the comet coma.

Figure 1.2-6 shows the configuration used for the MIRO experiment. In the expander unit a chirp is generated by impulsing a reflective array compressor (RAC) filter with 450-MHz center frequency, 180-MHz bandwidth, and 20-microsecond dispersion time. The amplified chirp is dispersed by a second RAC of the same type, again amplified and finally frequency doubled. The output signal of the expander unit is a chirp centered around 900 MHz with 360-MHz bandwidth and 40-microsecond dispersion time. The sync delay between the two expander subunits is about 20 microseconds. The compressor unit has an input frequency of 1350 MHz with a bandwidth of 180 MHz (the input bandwidth of the CTS). The input signal is multiplied by the expander output signal. The resulting 450-MHz difference frequency signal is filtered by another RAC of the same type as used in the expander unit, since a chirp slope inversion took place due to mixing into the lower sideband. The output of the compressor subunit is combined in a commutator, and split into real and imaginary parts. Subsequently the baseband signal is digitised by two eight-bit analog-to-digital converters. Within a 20-microsecond interval, 4096 digitised channels are distributed into an acquisition memory. The next spectrum is available after the next transform

interval and added channelwise to the former one. The memory read out interval is programmable between about 1 s and 5 s.

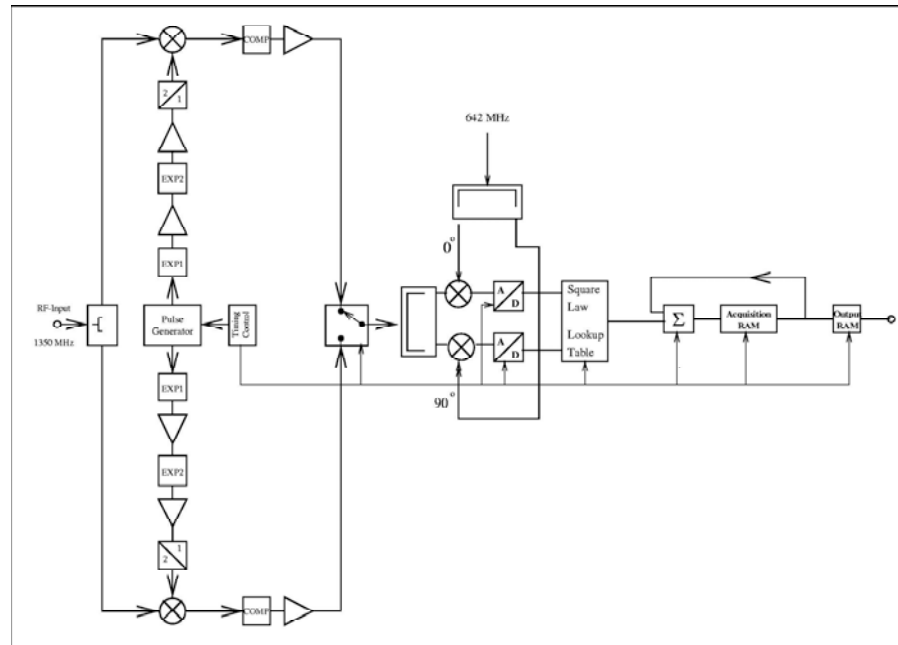

**Figure 1.2-6: Chirp transform spectrometer configuration**

### 1.2.2.6 Flight Computer

The flight computer for MIRO is a radiation hardened Reduced Instruction Set Computer (RISC) System/6000 (also referred to as RS/6000) which was used on the Mars Pathfinder and Mars Surveyor Projects. The design of this computer is based on the Rios Single Chip (RSC) RISC microprocessor with implementation of the VMEbus and RS232 interfaces and it provides up to 128 Mbytes of local memory (RAM). The processor is a single chip implementation of the IBM Model 220 workstation and it is considered to be in the POWER PC architecture family. In the MIRO application, the RS/6000 computer is operated at a divided down clock speed of 2.5 MHz to reduce power. This was accomplished by replacing the normal 40-MHz oscillator in the Miro RS/6000 with a 20-MHz oscillator

### 1.2.2.7 Command and Data Handling System

The Command and Data Handling (C&DH) system consists of all the electronics that control the operation of the instrument and communicates to the spacecraft via a serial port. The C&DH consists of the computer, flight software, engineering data electronics (EDE), and power supply. The computer receives, processes, verifies, and executes all commands that control the operation of the instrument via the flight software. The C&DH directs the acquisition of science and

housekeeping telemetry and formats the data in the appropriate packets. The EDE monitors selected temperature, voltage, and current levels within the instrument.

#### 1.2.2.8 Power Handling and Distribution

The 28-Vdc input from the spacecraft is converted into the various voltages needed by the instrument and distributed to the assemblies in the Electronics Unit and separately in the Sensor Back End Unit.

### 1.3 SOFTWARE DESCRIPTION

The onboard MIRO flight software controls the MIRO Instrument hardware. The software consists of a start-up routine followed by a generic executive. The executive activates Command and Data Handler, Data Collection and Transfer, Sequencing, Calibration, and Background Processor and these modules execute the appropriate routines for each required function.

The science data including calibration measurements are packetized and stored in a standard format. Housekeeping data including instrument health data (temperatures, currents, and voltages), mode of operation and science data are stored and reported in the telemetry packets (CCSDS format as described in the ESA Telemetry Standard).

A more complete description of the MIRO software can be found in Section 2.4.

#### 1.3.1 FLIGHT SOFTWARE DEVELOPMENT ENVIRONMENT

The WindRiver Tornado VxWorks kernel system for the RS/6000 was used for flight software development. The VxWorks Real-Time Operating System includes multitasking preemptive priority scheduling, intertask synchronisation and communications facility, interrupt handling support, and memory management. The host machine for the flight software development was a Sun Ultra-10 Workstation, running UNIX (Solaris OS v2.5.1).

### 1.4 OPERATIONAL MODES

MIRO is configured to have seven primary operational modes. Each mode provides a different capability, and has a different power consumption. (see Section 6 for a detailed description of each mode). The engineering mode (1 mode) provides a low power mode to obtain housekeeping measurements only. Single and dual receiver continuum modes (3 modes) are available to obtain the radiometric brightness within the MIRO field-of-view from the millimeter and submillimeter channels. These modes are useful for the investigation of the properties of surfaces such as those of the asteroids and comet nucleus. There are two spectroscopic modes (2 modes). One provides both smm and mm continuum (CTS/dual continuum) as well as the smm spectroscopic channels. The second provides the smm continuum channel, and the smm spectroscopic channels (CTS/smm). These spectroscopic modes allow a sensitive detection of specific

gases generated by the comet nucleus (and possibly the asteroids as well). A single mode, called the asteroid mode (1 mode), is designed for the two asteroid encounters. In this mode, the receiver is configured in the CTS/dual continuum mode. The data rate and setting of the first local oscillator are modified for the asteroid mode.

In the comet rendezvous stage of the mission, it is envisaged that MIRO will initially be turned on in a continuum mode to detect and measure the continuum emission from the nucleus. During the cometary and targeted mapping phases, a majority of the viewing will be in the one or two receiver/spectrometer modes to study outgassing processes, bulk composition, and coma formation. These phases will provide the highest spatial resolution for studying the nucleus. If limb sounding is feasible, it would enhance the minimum detectability of species, and allow greater resolution of the coma.

Following the mapping phase, MIRO plans to operate in the CTS/ dual continuum mode. During this phase, both nucleus and coma studies will be performed.

## 2 EXPERIMENT CONFIGURATION

### 2.1 PHYSICAL UNITS

MIRO consists of four distinct physical units and an interconnecting harness. The electronics unit configuration is shown in Figure 2.1-1, the sensor unit configuration is shown in Figure 2.1-2, the sensor backend electronics unit is shown in Figure 2.1-3, and the ultra stable oscillator is shown in Fig. 2.1-4.

The electronics unit consists of four assemblies bolted together into a single unit. The four assemblies include the spectrometer analog assembly, the spectrometer digital assembly, the data handling assembly and the command and power assembly. The electronics unit attaches to the spacecraft payload panel by 8 M5 screws. It is mechanically separated from the sensor backend electronics unit and can be up to two meters in distance away from it.

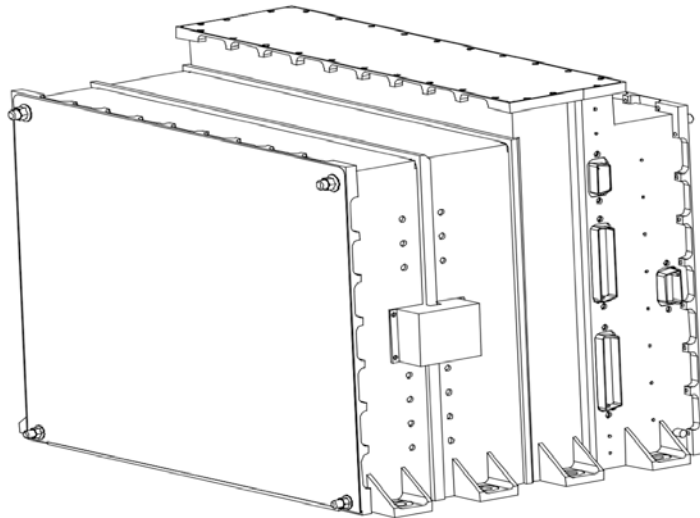

**Figure 2.1-1: Electronics Unit**

The sensor unit includes the following three major assemblies: telescope, baseplate, and the optical bench. It is mounted on the Rosetta payload (+Z) panel using the baseplate. The baseplate is a 405x250x25 mm machined aluminium panel with structural ribs with a total thickness of 25 mm. It is accommodated by top-mounting over a slighter smaller cut-out in the spacecraft payload panel. It is attached to the spacecraft payload panel by 10 M5 screws, making it thermally coupled to the payload panel, and hence collectively controlled. A 50 mm hole through the baseplate allows the RF signal from the telescope to pass through the baseplate to the optical bench.



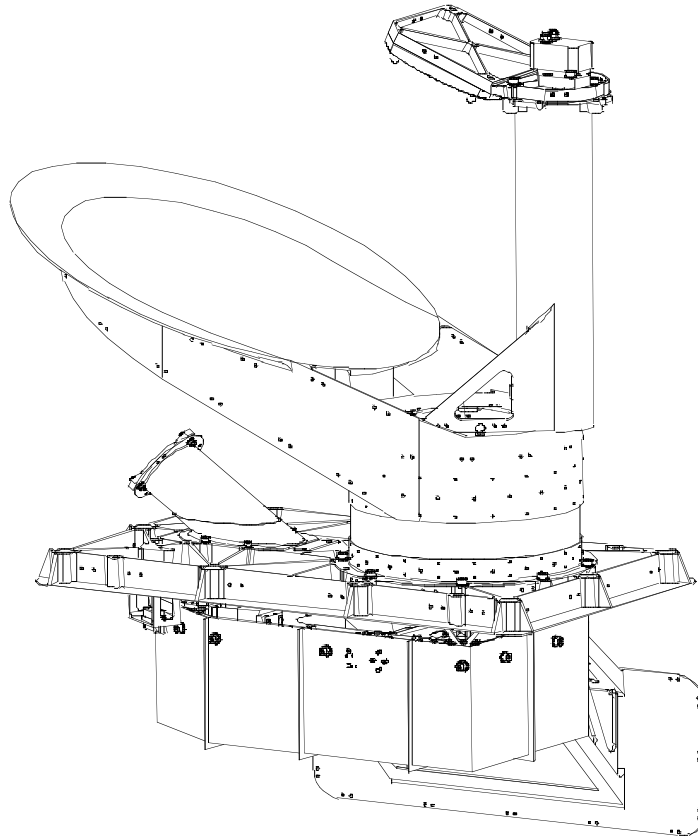
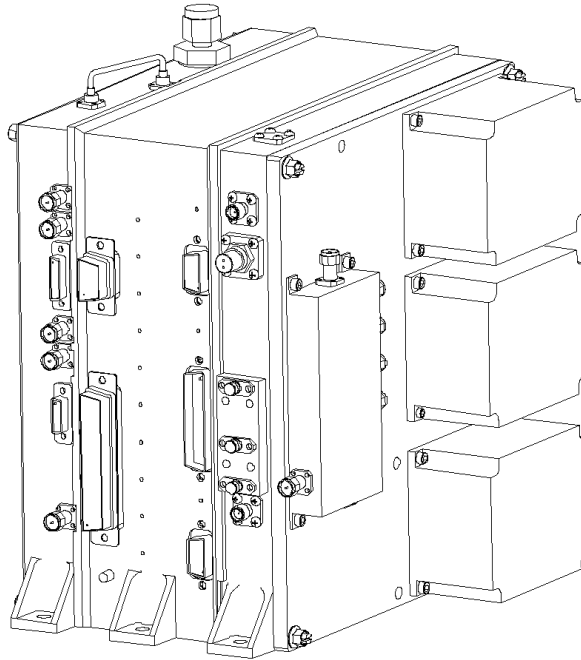

**Figure 2.1-2: Sensor Unit**

The telescope, consisting of a primary reflector, a secondary reflector and interconnecting structure, is constructed entirely from aluminium. It is attached to the outside of the baseplate by a thin-wall epoxy-glass cylinder, making it thermally isolated from the spacecraft. Also attached to the outside of the baseplate is the calibration cold target, which is isolated from the baseplate by a thin-wall cyanate ester cylinder.

The optical bench is attached to the baseplate side that is internal to the spacecraft. The attachment is through a kinematic mount making it thermally isolated from the baseplate. A radiator is mounted to the optical bench to remove the power dissipated on the bench. It attaches to the bench with eight M4 screws and is detachable during installation of the sensor unit. The calibration hot target is also attached to the baseplate internal to the spacecraft. Mounted on the optical bench are all the elements requiring optical alignment—the mirrors, calibration switch, polarization splitting diplexer, millimeter-wave receiver front-end and submillimeter-wave receiver front-end.

The sensor backend electronics unit consists of three assemblies bolted together: the power and housekeeping assembly, the intermediate frequency processor assembly and the phase lock loop assembly. It also has three frequency synthesizer assemblies mounted to the exterior surface of the phase lock loop assembly. The sensor backend electronics unit attaches to the spacecraft payload panel by 6 M5 screws.



**Figure 2.1-3: Sensor Backend Electronics Unit**

The ultra stable oscillator unit is attached to the spacecraft payload panel by 4 M4 screws. It is mechanically separate from but connected by harness to the sensor unit and the electronics unit. The ultra stable oscillator can be up to two meters away from the sensor unit and up to two meters away from the electronics unit.

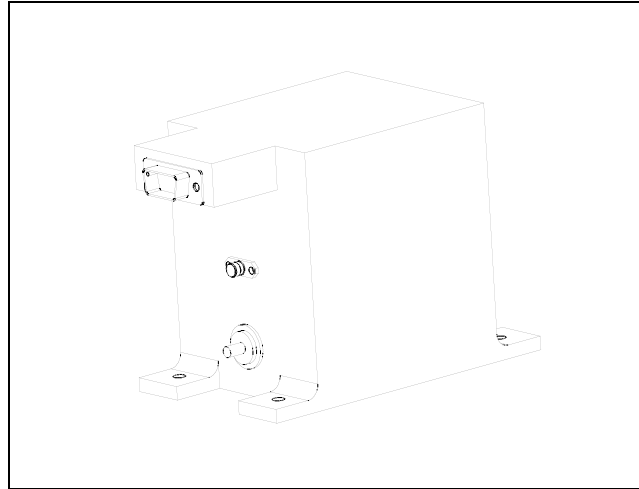

**Figure 2.1-4: Ultra Stable Oscillator**

## 2.2 CALIBRATION SWITCH MECHANISM

The only mechanism in the instrument is the calibration switch mechanism that switches the input to the front-ends from the telescope to either the cold calibration target or the hot calibration target. The configuration is shown in Figure 2.2-1. The actuator is a permanent-magnet stepper motor with a planetary geartrain. It is stepped at 27 pulses per second to drive the mirror at 0.27 degrees per second. Positive mirror positioning is determined by means of LED-photodiode pairs for each of the three positions. Soft and hard stops at the ends of travel, combined with the counter weighting, preclude a launch latch. The permanent magnet provides passive holding of position with the power off. A fail-safe device insures that the mirror can be positioned in the telescope position to receive science data if the actuator fails. The fail-safe is a thermally controlled shape memory metal pinpuller coupling between the actuator and the mirror. If needed, current is supplied to the pinpuller, retracting a retention pin. A spring returns the mirror to the telescope position. The mirror and the pinpuller are individually counter weighted to reduce torque to the motor during ground testing and launch.

The mechanism has been fully tested functionally and environmentally, and a qualification model has been life-tested to a number of cycles which exceed the requirement specified in EID-A 2.2.6.3 (4 times ground operational cycles plus 2 times orbit predicted cycles). All design features are previously used in flight experiments, or have gone through extensive testing for existing space programs.

Most of the mechanism is aluminium structure with Vespel bushings. However, the motor, geartrain, fail-safe device and sensors contain a variety of materials. Of interest to the spacecraft are the magnets and lubricant of the actuator. Similar stepper motors have been characterised and found to be well within the spacecraft

magnetic field requirement, even without shielding. The motor lubricant is a highly refined low vapour pressure oil, which has been used inside sensitive optical instruments. The shape memory metal alloy used in the pinpuller device was originally developed for the Wide Field Planetary Camera II Project and has gone through extensive breadboard testing.

By virtue of the counterweight to make ground testing of the mechanism possible, the low duty cycle to prevent overheating, the optical bench cover for protection and the small inertia/low speed of the moving mass, the mechanism is not expected to offer any constraints on the spacecraft.

The mechanism operates approximately 1/2 minute each thirty minutes during observations. For an eighteen-month escort mission, this is 0.3 months of operation.

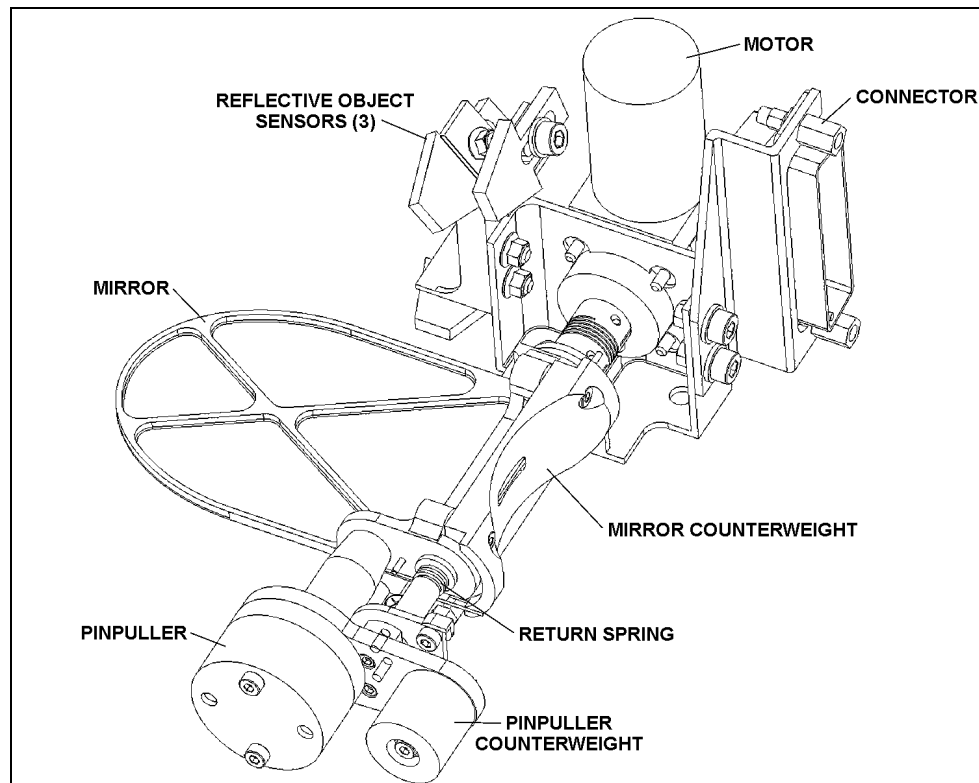

**Figure 2.2-1: Calibration Switch Mechanism**

**2.3 ELECTRICAL**

**2.3.1 POWER INTERFACE**

**2.3.1.1 General Interface Description**

The spacecraft power subsystem provides to MIRO:

- Electrical power from a voltage regulated DC main bus.
- Protected distribution and switching of power.

**Table 2.3.1-1: Power Supply Interface**

Function	Number of Main Lines	Number of Redundant Lines	LCL Class
+28 V Main Bus MIRO Experiment Supply (Switched and Current Limited)	1	1	E (109 W / 4.0 A trip-off limit)

**2.3.1.2 Power Distribution Block Diagram and Redundancy**

The power routing within MIRO is shown in Fig. 2.3.1-1. The 28 V Main and Redundant lines supply the power to the MIRO's Electronics Unit. The selected 28 V power line is filtered and sent to the Sensor Backend Electronics Unit, and the secondary supplies of the Electronics Unit. Secondary power to the Chirp Transform Spectrometer (CTS) and the Ultra Stable Oscillator (USO) is switched by control of MIRO's computer.

Figure 2.3.1-2 shows how the secondary power is switched by the MIRO's computer for the Millimeter and Submillimeter receivers for the various operating modes.

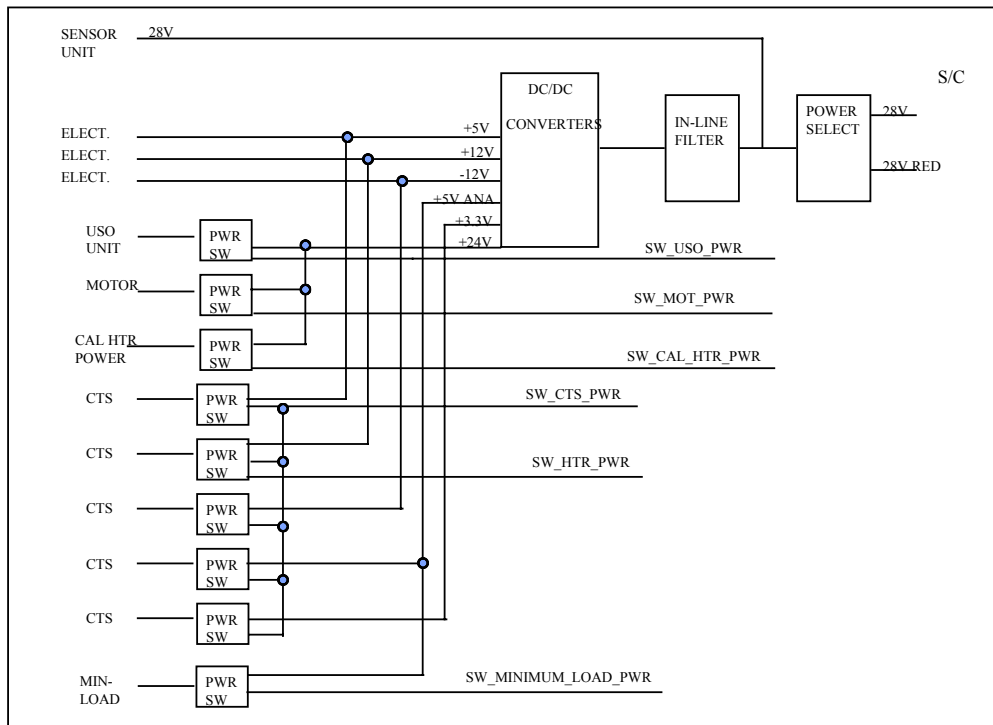

**Fig. 2.3.1-1: Power Distribution Block Diagram (Electronics Unit)**

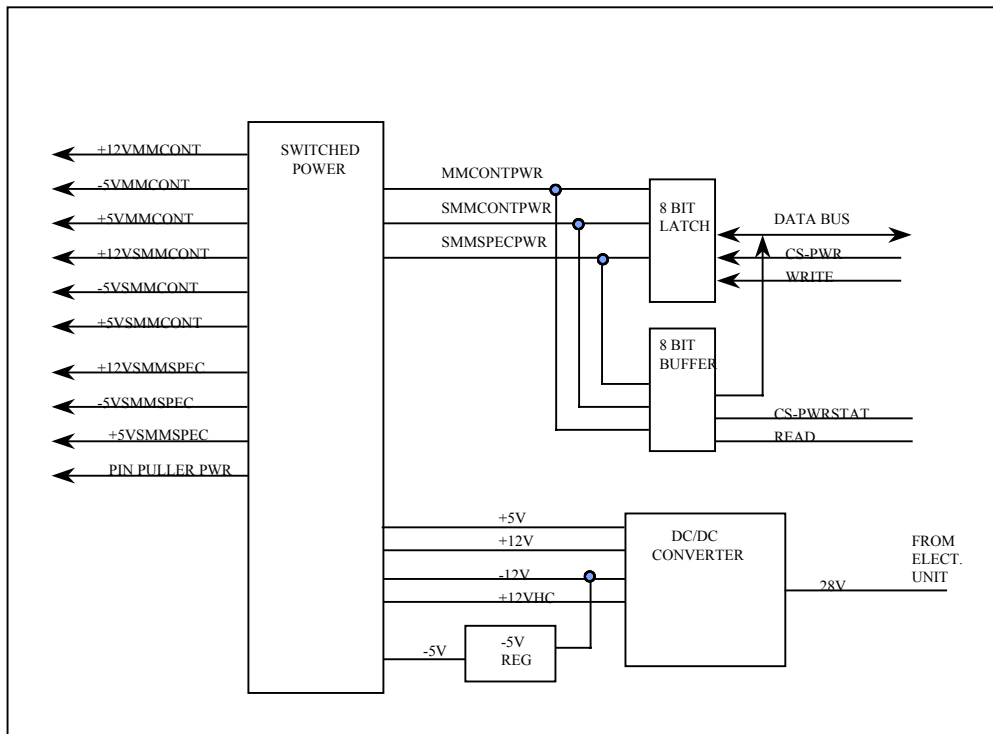

**Fig. 2.3.1-2: Power Distribution Block Diagram (Sensor Backend Electronics Unit)**

**2.3.1.3 Experiment Power Requirements**

The power allocation for MIRO is 43 W average over a mission phase. The average is met by operational scenarios in each mission phase, (not by direct use of the average power). The MIRO power modes are defined as follows

1. Engineering Mode (sometimes called Hibernation )
2. Millimeter Continuum Mode (MMC)
3. Submillimeter Continuum Mode (SMMC)
4. Dual Continuum Mode
5. Submillimeter Spectroscopic Mode (SMMS)
6. Spectroscopic, dual continuum (sometimes called CTS/Dual continuum)
7. Asteroid Mode

Table 2.3.1-2 shows the best estimates for MIRO’s power consumption for each of the 7 modes. Column 1 shows the modes as defined above. Columns 2, 3, and 4 show the power consumption for the calibration heater, the USO, and the CTS warmup, respectively. The submillimeter and millimeter Low Noise amplifiers power consumption are shown in columns 5 and 6, respectively. Column 7 shows the power consumption with the options turned off. This is the normal power consumption for each mode. The maximum and minimum powers are shown in columns 8 and 9, respectively, depending on the status of the options. The negative powers shown in columns 5 and 6 reflect the fact that the low noise amplifiers are normally turned on when the smm and mm receivers are turned on, however they can be powered off thereby reducing the power. Table 2.3.1-3 provides information about each option.

**Table 2.3.1-2: MIRO Power Consumption by Mode**

1	2	3	4	5	6	7	8	9
MODE	OPTIONS							
	CalHtr	USO	Warmup	smmLNA	mmLNA	Option Off	Max	Min
	Watts	Watts	Watts	Watts	Watts	Watts	Watts	Watts
1	4.76	9	9	N/A	N/A	18.3	41.06	18.3
2	4.76	9	9	N/A	-1.68	24.7	47.46	23.02
3	4.76	9	9	-1.68	N/A	26.1	48.86	24.42
4	4.76	9	9	-1.68	-1.68	32.4	55.16	29.04
5	4.76	Included	N/A	-1.68	N/A	68	72.76	66.32
6	4.76	Included	N/A	-1.68	-1.68	69	73.76	70.4
7	4.76	Included	N/A	N/A	N/A	73	73	73

Table 2.3.1-3: Comments on the power options shown in Table 2.3.1-2

Comments on Options In Table 2.3.1.2	Description
USO	Powered on automatically when you enter any CTS mode; The USO can be powered on and off from all modes; Remains on when you move from mode to mode; The USO power is never turned off automatically; A command to power-off the USO off is required.
mmLNA	Powered on automatically when the mm receiver is powered on; The only way to turn the LNA off (with mm on) is by direct command; Once turned off, the LNA stays off until 1) commanded on, 2) power off/on the instrument, or 3) a software restart is performed.
Smm LNA	Powered on automatically when the smm receiver is powered on; The only way to turn the LNA off (with smm on) is by direct command; Once turned off, the LNA stays off until 1) commanded on, 2) power off/on the instrument, or 3) a software restart is performed.
CTS warmup	The CTS warmup command is only issued from engineering, mm continuum, smm continuum, or dual continuum modes;
CTS heater	This command is used only when the instrument is in a CTS mode This command sets the temperature regulation point of the SAW filters; internal clocks are not turned on until CTS mode is entered. There is a high and low power setting which determines the rate at which the filters are warmed; it is also possible to set the power to zero. The CTS heater is turned on automatically when you enter any CTS mode but the filter temperatures are set either by a global variable or by a previously set temperature.

## 2.4 SOFTWARE

### 2.4.1 OVERVIEW

The MIRO software architecture is designed to be compliant with the ESA EID-A while at the same time also fulfilling the science functional requirements. The EID-A primarily defines the MIRO software interface to the spacecraft. The science functional requirements define the requirements levied upon the software regarding the return of all science data. **This Software Specification Document (SSD) serves to define the software architecture and includes relevant detailed design information. No specific requirements are listed in this document except for the science functional requirements listed in Appendix C. [need to ask Nowicki about this]** Upon completion and review of the SSD, the software coding and testing phase will commence. This release defines the functionality to be delivered for the FM delivery. The final FM delivery represents the software that will be delivered to ESA and execute on the FM hardware platform. The FM delivery will also contain software to allow for the diagnosis of H/W and S/W interface problems, and will be used during FM hardware integration to verify the



functionality of all the FM hardware. Following delivery of the MIRO instrument to ESA the diagnostic output from the MIRO software will still be available via the serial output from the computer should that become necessary.

The primary data and control flows are shown in Figure 2.4.1-1. Collection of chirp transform spectrometer (CTS) data, millimeter continuum data and submillimeter continuum data constitute the primary task of the MIRO software. The MIRO software architecture has been designed to maximize the collected amount of science data over time. Many different operating sub-modes have been defined to reduce the amount of data returned, to allow for operation during mission phases when other Rosetta instruments are competing for downlink bandwidth. The collected science data is then packetized as per the EID-A TM definition and transferred to the Rosetta spacecraft.

## 2.4.2

### COMMANDING

There is no internal sequence machine resident within the MIRO flight software. It is simply command driven, and takes limited action on its own. All commands will be issued to the MIRO software via either on board control procedures (OBCPs) executed by the Rosetta spacecraft computer or as nominal mission timeline (MTL) commands. OBCPs are used where closed loop control is required over the MIRO software by the spacecraft computer. Closed loop control is where the DMS would monitor telemetry generated by the MIRO software and alter the commands being sent based on that telemetry. The nominal MTL commands are used for open loop commanding where the spacecraft issues MIRO a command and does not perform any processing of MIRO generated telemetry. Most of the MIRO commanding will be via the MTL. Exceptions to this will include startup and shutdown OBCPs.

The MIRO OBCPs and nominal MTL commands will be uplinked to the spacecraft as required to support operations during the various phases of the mission. The MIRO S/W will not be altering the contents of its eeprom resident data. Most operating parameters will be given default values that can be overridden by uplinked telecommand. It is envisioned that during the course of the mission, a small list of parameter changes, software patches, etc. will be sent to the MIRO software each time it is restarted via the startup OBCP. The software design has been structured to support this operations concept. Any MIRO information that needs to be monitored and/or acted upon by the DMS will be defined in the EID-B.

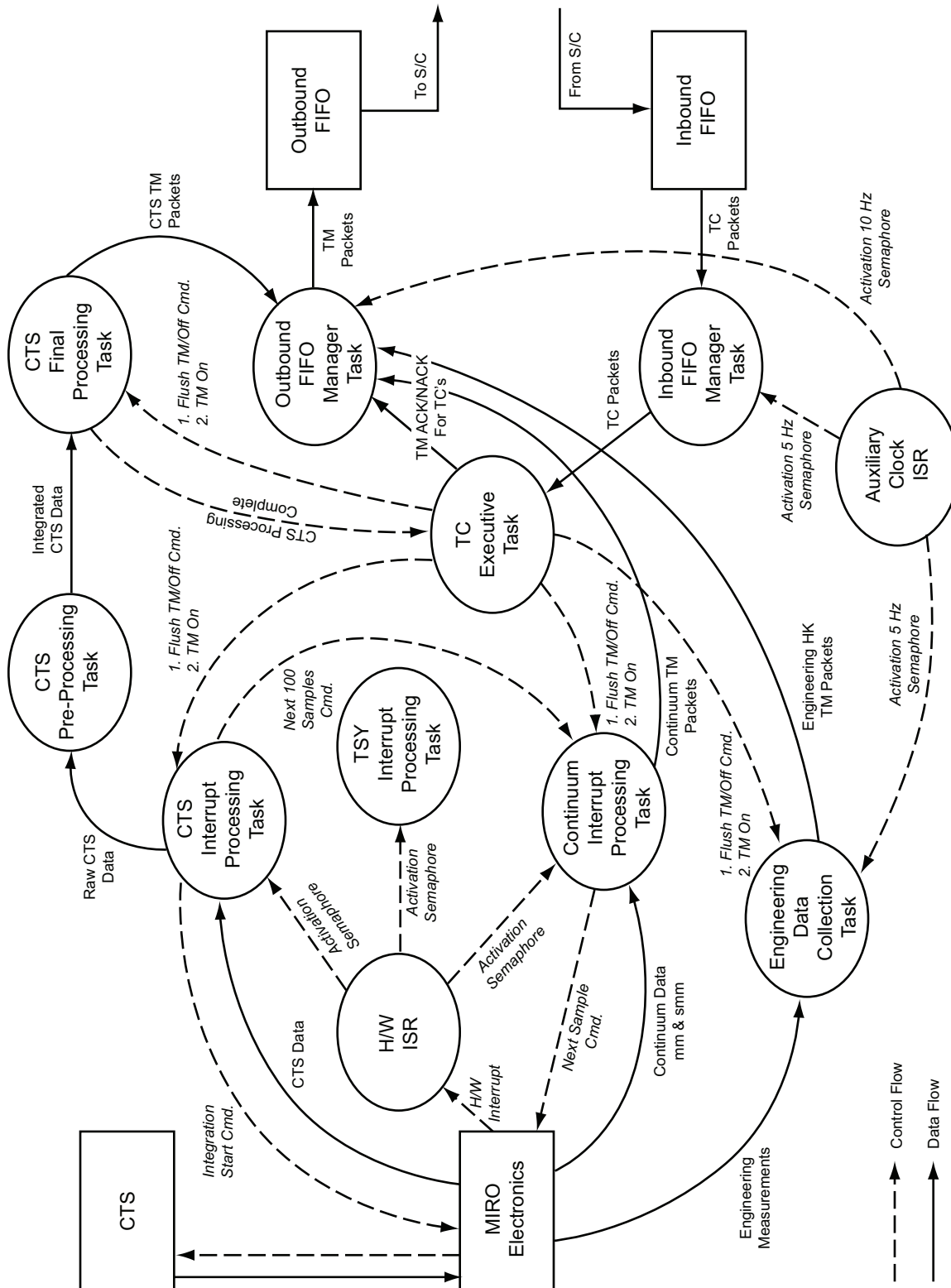

Figure 2.4.1-1: MIRO Software Data Flow and Control Diagram

### 2.4.3 **HARDWARE INTERFACES**

The primary definitions of the interfaces between the MIRO software and the associated MIRO hardware are described in the individual MIRO hardware ICDs. This section will define the software interface to the hardware as viewed from a software development perspective. Most of the information contained in this section is the result of conversations with the various hardware PEMs. See Figure 2.4.3-1 for an overview of the MIRO hardware.

### 2.4.4 **SPECTRAL DATA INTERFACE**

#### 2.4.4.1 **CTS Control**

The interface to the CTS is via a bi-directional port. It is a 32-bit interface, which is both read from and written to. Access to this interface is via the VME bus. The software that executes to read from or write to the CTS is simply a read or write from a specific memory address. The CTS is an intelligent hardware device that is programmed by the MIRO software to integrate for a specific period of time. MIRO is using a programmable duration (approximately 4.95 seconds) for all spectrometer scans. When the CTS has completed each scan, an interrupt is generated and sent to the MIRO software.

A signal called 'busy' is generated by the CTS while it is performing each scan. In the case of an internal CTS error or an SEU event which disables the CTS, the busy line will remain high. The busy line remaining high after the CTS scan should have completed will be the triggering event for determining that the CTS has failed. It is not known whether the CTS will generate an interrupt or not during these 2 failure modes. Therefore only the busy line is being used as the failure indicator. SEU processing within the CTS is enabled by a special command sent to the CTS every time it is powered on. The nominal powering on sequence for the CTS will contain an 'SEU Enable' command as the last action.

The CTS contains 4 internal sum of squares (SOS) tables which are 256\*256 16-bit values. Prior to operation the SOS tables need to be loaded with data. The process of determining what values to load into the SOS tables prior to nominal data collection is called the CTS internal table calibration process. The table calibration of the SOS table requires about 45 seconds to complete. It will be recalculated each time the CTS is powered on, and also periodically during nominal operation via ground TC.

The MIRO software can also control the CTS internal heater temperature and power consumption. These are also implemented as a ground TC sent to the MIRO software, which is then sent to the CTS hardware.

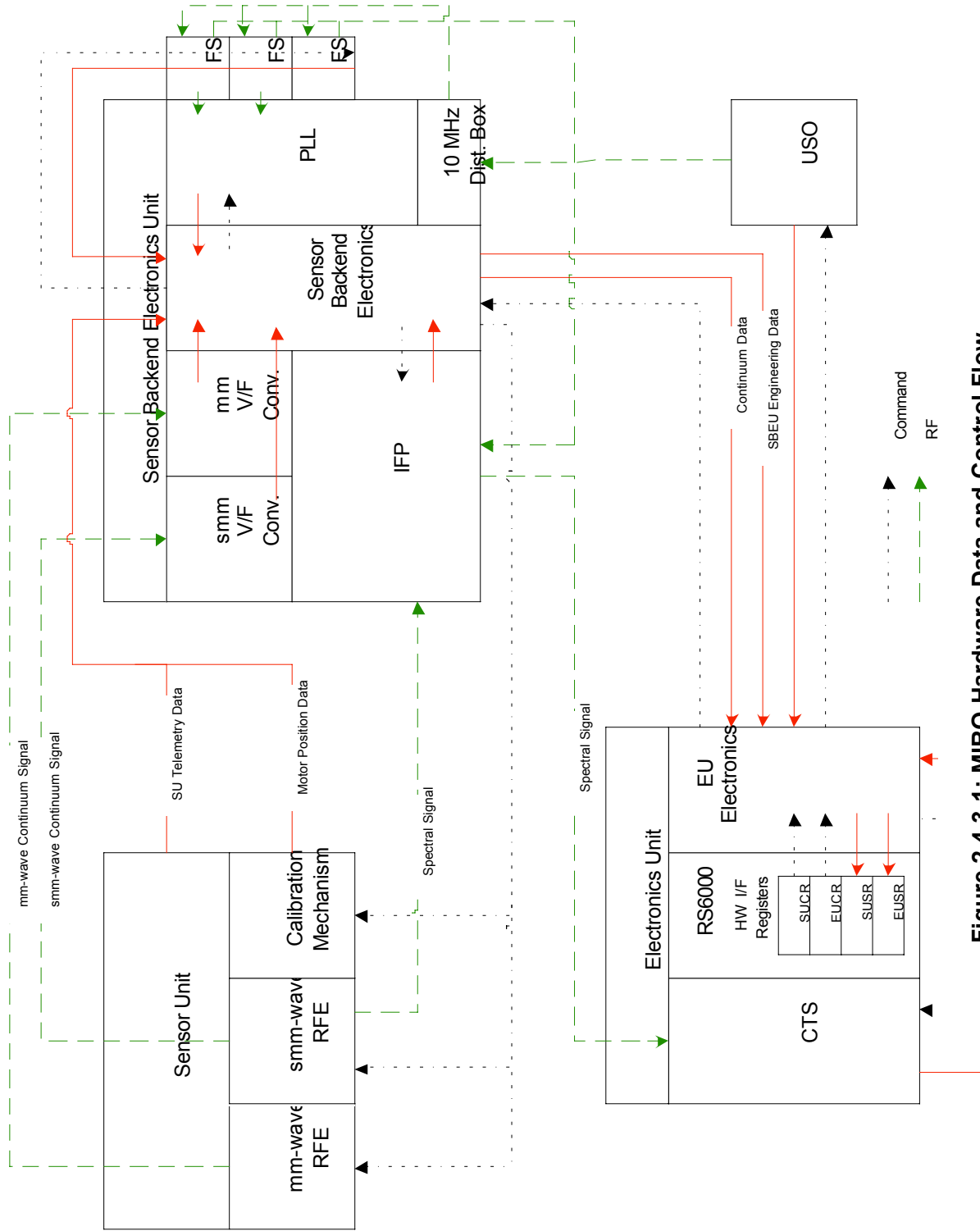

**Figure 2.4.3-1: MIRO Hardware Data and Control Flow**

#### 2.4.4.2 PLL, LO and IFP Control

There is additional hardware that feeds the RF signal into the CTS after performing some pre-processing of the signal. The Sensor Unit Control Register (SUCR) is the means by which the other hardware is controlled.

There are 4 bits in the SUCR called IFP Power Control. These bits do not control power but control the gain of the RF data going into the CTS instrument. This is a very coarse control. The setting of these bits will be via a ground TC. Default values will exist in the software.

There is a bit in the SUCR for LO frequency control. This is used to switch the LO between the 2 possible settings. The LO is switched before each CTS scan is started, except when running in asteroid mode or raw data mode. There are 4 corresponding bits (phase lock alarms) in the Sensor Unit Status Register (SUSR) showing when the set frequencies have stabilized following an LO switch. See the hardware ICD for a description of whether a 0 or 1 indicates that the frequency output is not stable. The 4 alarms will need to be polled following the changing of the LO frequency to confirm that the new frequencies are locked in. The alarms will be polled during the scan at a 20 Hz rate, coinciding with continuum data collection. Any alarms that have changed will be reported back in the CTS telemetry.

When the CTS is not powered, the LO frequency cannot be controlled. The frequency changes will need to be skipped when running in a power configuration where the CTS is not turned on.

There is a bit in the SUCR called `load_freq` that gets set to load the 3 frequency synthesizer chips. A set of 3 fixed 19-bit values are then loaded by the FPGA hardware into the frequency synthesizers. The software will reload these every 30 minutes, before performing the instrument calibration. This should happen after the CTS is powered on and warmed up.

#### 2.4.5 CONTINUUM DATA INTERFACE

The exact bit level definitions of all the registers discussed below can be found in the H/W ICDs. The following paragraph is supplied to familiarize the reader with the basic H/W involved in obtaining the data.

The I/F to the sensor backend electronics unit (SBEU) is via the 32-bit (SUCR). The software loads 16 bits at a time. All 32 bits are processed each time. The data from the SU is returned in the SUSR (64 bits). A software query initiates the data return. The contents of the SUSR include millimeter data (16 bits), sub-millimeter data (16 bits), SU and EU A/D data (12 bits) and various other data. Sensor unit A/D conversions require a small delay in order to return valid conversions. This delay is built into the software. The EU A/D conversions require no delay. A bit in the main control register (MCR) is used to set the millimeter and/or sub-millimeter sampling rate of 50 milliseconds. A 100-msec sampling rate is

available in the hardware. However, the MIRO FSW is not designed to use this rate. When continuum data is ready, the H/W generates an interrupt that requires processing by the software.

There are 3 sets of 4 bits used to control voltage or bias settings for the mm and smm receivers. These will be set to an optimum value prior to launch and the S/W will have the capability to change them in flight. This will be via ground TC.

#### 2.4.6

#### ENGINEERING DATA INTERFACE

The I/F to the electronics unit (EU) consists of a 16 bit Electronics Unit Control Register (EUCR) and a corresponding 16 bit Electronics Unit Status Register (EUSR). The A/D data is collected from either the SUSR or EUSR depending on where the channel being sampled is located. The SU provides 32 channels of engineering data and the EU provides 24. All measurements are 12 bits. A bit in the MCR is then toggled to start the conversion running. The SUSR and EUSR each contain an end of conversion bit (EOC) indicating when a specific A/D conversion is complete. Polling of this bit would normally be required as there is no interrupt associated with the EOC. For the FM delivery the software will include built in delays to allow the conversions time to complete. The qq milliseconds of delay that occur during the conversion process have no impact on the running code as the conversions are 200 milliseconds apart and the previous conversion completes before the next one is started.

The FM approach for performing an A/D conversion is as follows (assuming SU channel):

1. Write the S/U channel number to the SUCR mux.
2. Clock it out to the H/W.
3. Write channel number 0 into the EUCR mux.
4. Clock it out to the H/W.
5. Delay 16-32 milliseconds.
6. Toggle the start S/U convert bit in the MCR.
7. Toggle the start E/U convert bit in the MCR.
8. Wait 16-32 milliseconds to allow the conversions to complete.
9. Set the SU status retrieve bit in the MCR.
10. Wait 16-32 milliseconds.
11. Read the converted S/U value out of the SUSR.

It should be noted that the S/U and E/U engineering conversion routines contain dummy conversions for the opposite interface. This addition was made because S/U conversions cause power fluctuations due to sharing a common power supply with other electronics. These power fluctuations alter the continuum data enough to be detected by ground processing software. The 'skip engineering cycles' TC was added to allow for even further reductions of this noise.

## 2.4.7 POWER INTERFACES

The MIRO software has access to a total of 14 separate power switches. Some of these switches turn on and off multiple components. In some cases (i.e. CTS), multiple switches are required to turn on a single component.

The first eight of these are via bits in the SUCR. The other 6 are via bits in the electronics mux register (EMUX).

1. Millimeter continuum (multiple components), 2 switches
2. Sub-millimeter continuum (multiple components), 2 switches
3. Spectral data (multiple components), 2 switches
4. Pin-Puller power
5. Mirror motor power
6. Ultra Stable Oscillator power
7. CTS
  - a. +5 Volts
  - b. +3.3 Volts
  - c. +5 Volts analog
  - d.  $\pm 12$  Volts
8. Hot target power

The spectral data power is needed along with all the CTS power for any CTS operation. The spectral data power should be powered on after the CTS power. The USO is only needed for CTS operation, and it is automatically turned on every time the CTS is powered on. There is also a ground command to separately turn the USO on and off. The USO may be turned on well in advance of the CTS to allow for additional warm-up beyond what is required for just the CTS. HK telemetry packets will be generated during the warming up process so the warm up process can be monitored. The intent is to keep MIRO in the engineering mode until all the desired warm-up temperatures have been reached. The 3 sets of 4 voltage bias bits in the SUCR should be set prior to powering the associated (mm or smm) electronics on. The multiplier power is on all the time so that is not applicable to the setting of its 4 bits. A very short warm-up time is required for the mm and smm electronics. Data will be taken from these immediately after powering on.

Overall power control is via a combination of ground command and internal control. Mode switching will cause a pre-defined set of power control actions to occur prior to entering the new mode. Ground commands are used primarily to fine tune such things as IFP power control and SMM multiplier bias. No 'sanity checking' will be performed by the onboard software with respect to processing the ground TCs. The ground operations personnel will be responsible for verifying that the commands sent to the instrument are correct and coherent.

There are 8 temperature set points and 3 power level settings within the CTS. One of the 3 power settings is an off setting. There will be a new control for 'Pulse Position'. This may need to vary based on the temperature level. The FM software

will process the ground command for the pulse position to change the pulse position.

#### 2.4.8 MIRROR CONTROL INTERFACE

As part of the MIRO instrument calibration process, the viewing target is changed from space to a hot target followed by a cold target. Data is collected while pointing at each of these targets. There are 3 mirror positions: 1=space, 2=hot, 3=cold. The SUCR has 2 associated bits: mirror power control on/off and mirror direction forward/backward. There is another word where the number of mirror steps is loaded to cause the mirror to move. The mirror power bit should be set first prior to loading the step word, because loading the step word starts the countdown whether it is powered or not.

The mirror moves at 100 pulses per second and each pulse/step moves the mirror 0.27 degrees. Position 2 is 48.6 degrees from position 1, which is 180 steps requiring 1.44 seconds. Position 3 is 22.95 degrees from position 2, which is 85 steps requiring 0.68 seconds. There is a hard stop in both directions between positions 1 and 3. To go back to position 1 from position 3 requires changing the mirror direction to backward and going 180+85 steps = 265 total steps requiring 2.12 seconds.

The feedback to the S/W is 3 bits in the SUSR called mirror position. These will be set by the mirror electronics when the mirror is in the required position. All movements between 2 positions are accomplished via an initial gross movement followed by a series of single steps until the mirror position sensor indicates that the final position has been achieved.

All other data rate calculations in this document and appendices assume that the 3 mirror movements will require 5 seconds total time. The estimated movement time totals 4.24 seconds and the remainder allows for additional processing overhead.

#### 2.4.9 PIN-PULLER CONTROL

There is a bit in the SUCR called the pin-puller bit. This activates the pin-puller mechanism. This is a fault recovery mechanism if the mirror is not responding as it should. Activation of the pin-puller will allow the mirror to move to position 1 automatically. The S/W will then move the motor enough steps, in reverse, to get back to position 1 from where ever it was. Backing up into the stop does not cause any wear and tear. At position 1, the pin-puller will automatically reinsert itself where it belongs. Mirror operation should be back to normal at this point. The S/W will generate an alarm if a pin pull is required and another confirming that it worked or didn't. An automated response has been built into the code to address cases where the use of the pin-puller mechanism is required. See fault protection section below.



#### 2.4.10 INBOUND FIFO INTERFACE

The inbound FIFO is 512 words (1024 bytes). It is accessed by reading a 16-bit integer value from a memory location that is mapped, via vxworks, to the VME bus. There are status flags associated with the FIFO hardware that are accessible to the software. They are empty, half-full and full. The hardware keeps track of the read pointer. The software only needs to read from the required memory location to transfer data out of the FIFO. Polling of the status flags are required as the FIFO generates no interrupts to the software.

#### 2.4.11 OUTBOUND FIFO INTERFACE

The outbound FIFO is sized to be 4096 words (8192 bytes). It is accessed by writing a 16-bit integer value to a memory location that is mapped, via vxworks, to the VME bus. There are flags associated with the FIFO hardware that are accessible to the software. They are empty, half-full, full,  $\frac{1}{4}$  full and  $\frac{3}{4}$  full. The hardware keeps track of the write pointer. The software only needs to write to the required memory location to transfer data into the FIFO. If the FIFO is read after being reset it will output a 16-bit word containing zero. The initial plan was to use this feature of the FIFO hardware to indicate to the S/C that we had no data to send. If the S/C reads a zero, it will indicate that we have no data to send. This proved to not be a robust enough design. See the description of the Outbound Fifo Manager Task for further details.

The software is able to transfer data into the FIFO over the VME bus about 4x faster than the spacecraft is capable of reading the FIFO. In spite of this, a race condition was detected during as mentioned above.

#### 2.4.12 INTERRUPTS INTERFACE

The EU hardware handles all buffering of interrupts such that the software only needs to address the processing of 1 interrupt at a time.

There are only 3 interrupts that the FSW will receive:

1. Time Synchronization
2. CTS
3. Continuum

**Time Synchronization:** This will occur every 8 seconds. If a new spacecraft TC packet has been received since the prior interrupt, the time value contained in the packet will be stored as our current spacecraft time.

**CTS:** This interrupt occurs when the spectrometer has finished collecting data for the programmed interval. This will be approximately every 5 seconds. Upon receipt of this interrupt the FSW will proceed to read the 16384 bytes of data out of the spectrometer. Since the readout requires 0.127 seconds, care must be taken so that other higher priority processing can interrupt this if required.

**Continuum:** The last interrupt that will be generated is for the continuum data. This interrupt will occur every 50 milliseconds. The FSW will need to read the collected data out and restart the continuum data collection.

## 2.5 BUDGETS (MASS, POWER, DATA RATES)

### 2.5.1 MASS

The measured mass of the MIRO instrument, in kilograms, is provided in Table 2.5.1-1.

**Table 2.5.1-1: Measured mass of the MIRO instrument in kilograms**

Unit	Sub-unit	Sub-unit mass (kg)	Unit Mass (kg)
SU			6.7
	Telescope	2.1	
	Baseplate	1.8	
	Optical Bench	2.8	
SBEU			5.78
USO			1.12
EU			6.27
Wiring Harness			0.45
Total Mass			20.32

SU=Sensor Unit; SBEU=Sensor Backend Electronics Unit; USO = Ultra Stable Oscillator Unit; EU=Electronics Unit). This table does not include mass of multi-layer insulation (MLI).

### 2.5.2 OPERATING POWER

The operating power of the MIRO instrument, in watts, is provided in Figure 2.5.2-1. Table 2.3.1-2 provides a detailed breakdown of power for the various modes.

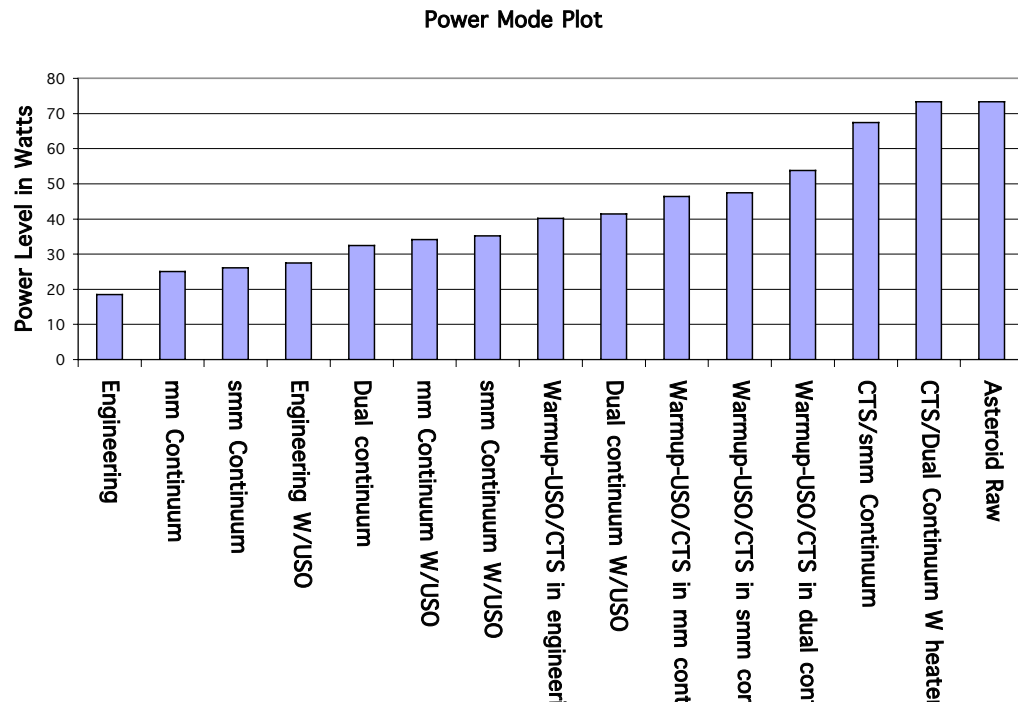

**Figure 2.5.2-1: MIRO Instrument Operating Power (in watts)**

### 2.5.3 DATA RATES

The nominal data rates for MIRO ranges from 0.23 Kbits/s for the continuum modes to 1.93 Kbits/s for the full spectroscopic mode. The peak data rate, used when high time resolution is needed, is 2.53 Kbits/s. The total accumulated data volume, from launch through the near perihelion phase is estimated to be 9.213 Gbytes.

### 2.6 NON-OPERATING HEATERS

(None)

### 2.7 SPACECRAFT POWERED THERMISTORS

2 main and 1 redundant

### 2.8 PYRO LINES

The MIRO instrument uses no pyrotechnic devices.

## 2.9 OBDH CHANNEL

### 2.9.1 CHANNEL ALLOCATION

MIRO's channel allocations are listed in Table 2.9-1.

**Table 2.9-1: Experiment OBDH Interface Channels/Functions**

Interface	Signal Type or Function	Main	Redundant
Telecommand Channels	Memory Load Commands	1	1
	High Power On/Off Commands	0	0
Telemetry Channels	16-bit Serial Digital Channel	1	1
	Fast Serial Interface (typ. Mbps)	N/A	N/A
Monitor Channels	Spacecraft Powered Thermistors	2	1
	Bi-level Channels	0	0
	Analogue Channels	0	0
Timing Channels	High Frequency Clock	0	0
	Broadcast Pulse (TSY)	1	1
Special Synchronisation Channels	Converter Synchronisation Signal	N/A	N/A
	Frequency reference	N/A	N/A

### 2.9.2 TELEMETRY

MIRO will send telemetry source packets which consists of both Science Packets and Science Housekeeping Packets. MIRO source packets will conform to the ESA Packet Telemetry Standard, ref. PSS-04-106, Iss. 1.

### 2.9.3 TELECOMMAND

MIRO telecommand packet will be consistent with the format as defined in the ESA Telecommand Standard, ref. PSS-04-107, Iss. 2. Telecommand will provide the following at a minimum: Instrument commands, memory loads and broadcast time.

MIRO has no requirement for discrete commands through the RTU.

### 2.9.4 BIT RATE REQUIREMENTS

The engineering and scientific bit rates are given in Volume 6, Table 6.4.3-1 of the EID-B. The optimum bit rate is the highest bit rate and occurs for the full calibration mode. The minimum rate occurs for the millimeter continuum mode. There are no special requirements (high speed data transmissions for defined period).

There are no specific constraints or preferences for the implementation of the Packet Telemetry, i.e. whether variable or fixed packet length per mode or limitations on maximum packet size.

MIRO will provide a 16-bit word which indicates the length of the packets if a packet is available or zero if no packet is ready for pickup.

### **2.9.5 TIMING**

S/C time updates will be sent to MIRO along with the TSY pulse for synchronizing. MIRO will use its internal clock and counters to add to the S/C time updates. No S/C High Speed Clock is required as long as the period between S/C updates is less than 1 hour.

### **2.9.6 MONITORING**

The DMS is expected to monitor parameters from the housekeeping packets and compare values to a stored table to determine anomalies. Results are stored to be downloaded for further investigation.

#### **2.9.6.1 Telecommands and Verification**

MIRO telecommands and verification is discussed in EIDB-2.8.

#### **2.9.6.2 Experiment Status and Event Reporting**

MIRO experiment status and event reporting is discussed in EIDB-2.8.

### **2.9.7 ELECTRICAL INTERFACES CIRCUITS**

#### **2.9.7.1 General**

MIRO's electrical interface will be compatible with the RTI interface specified in the Spacecraft Data Handling Interface Standard, ref. ES-PSS-47/TTC-B-01, Iss. 1.

A Standardised Balanced Digital Link (SDBL) will be used to perform the serial data transmission.

#### **2.9.7.2 Telemetry**

Refer to Figure 2.9.7-1 the implementation of Telemetry interface circuits.

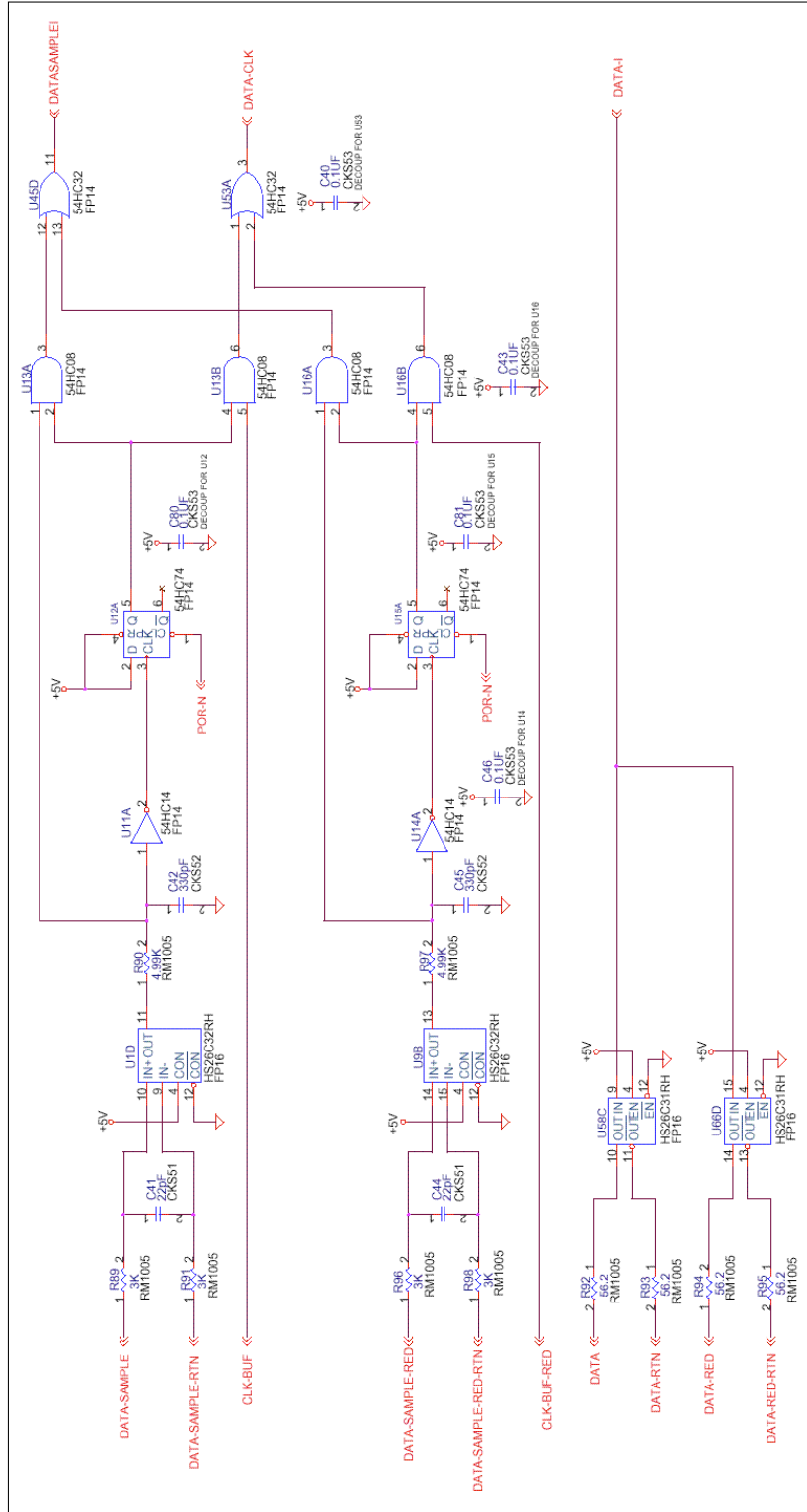

Figure 2.9.7-1: Telemetry Interface Circuit—Data Output and Sample Input

2.9.7.3 Telecommand

Refer to Figure 2.9.7-2 for the implementation of the Telecommand interface circuits.

MIRO does not require switch closure or high power on/off commanding.

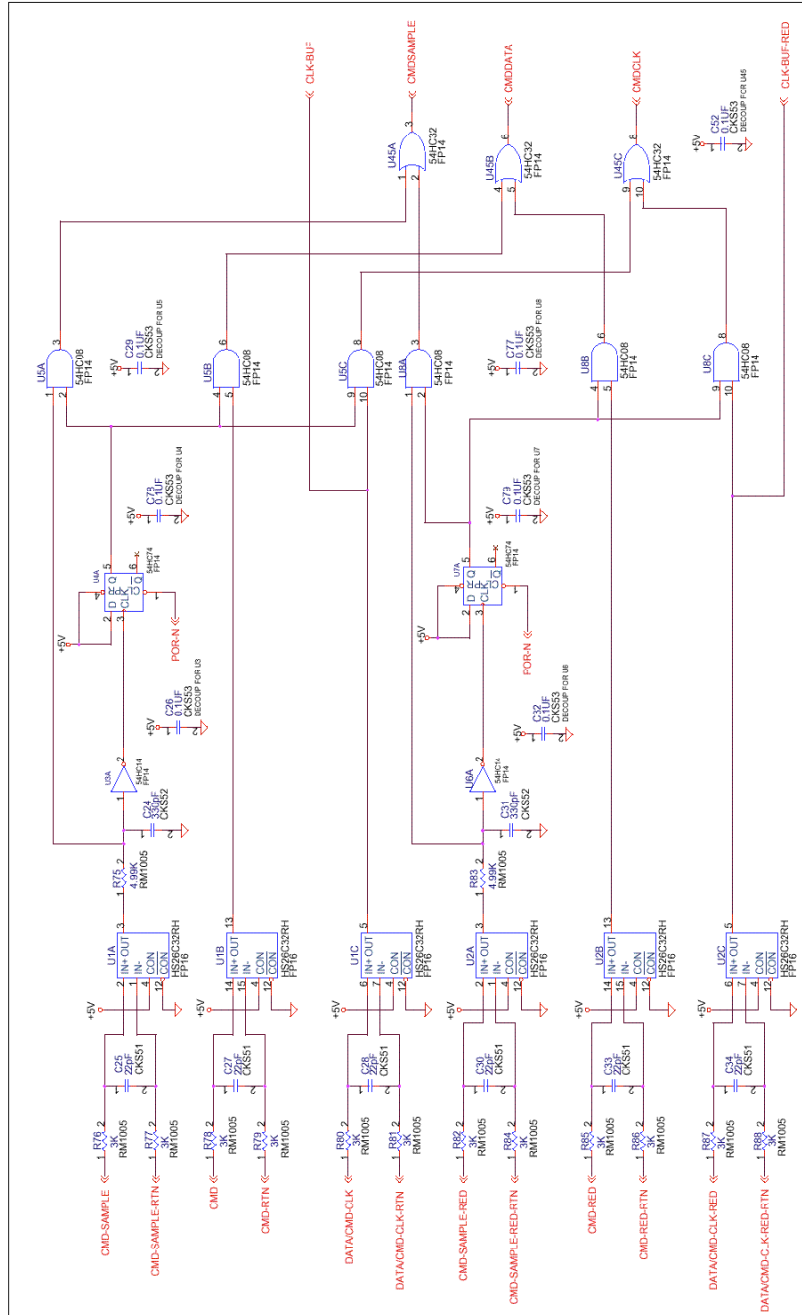

Figure 2.9.7-2: Telecommand Interface Circuit—Data Input, Clock Input, (combined with TM) and Sample Input

#### 2.9.7.4 Broadcast Pulse (TSY)

Refer to Figure 2.9.7-3 for the implementation of the Broadcast Pulse (TSY) interface circuit.

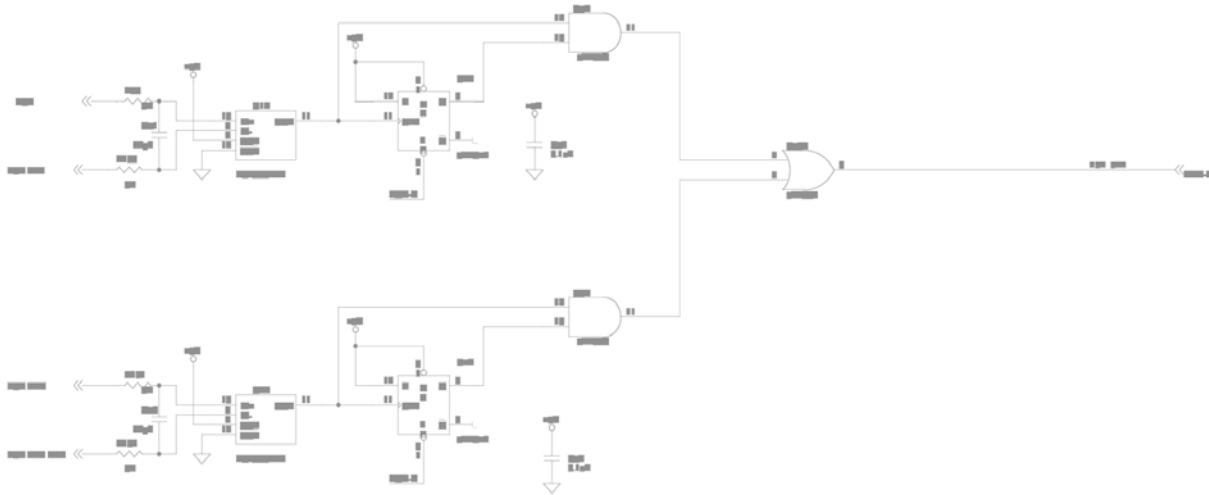

Figure 2.9.7-3: Broadcast Pulse (TSY) Circuit Interface [need new graphic]

#### 2.9.7.5 Environmental and Status Monitoring

Two temperature sensors within MIRO will be monitored by the S/C. One located near the sensor electronics and the other on the optical bench. Only the sensor on the optical bench will have a redundant temperature sensor.

#### 2.9.7.6 Redundancy

MIRO will provide for redundancy on all signal lines to/from the OBDH. MIRO will design its interface circuits to prevent a single failure from propagating to its redundant interface.

MIRO is configured as non-redundant and will OR the main and redundant signal in such a way as to enable proper operation if either signal is stuck in its high or low state.

MIRO will provide both a main and redundant signal to the OBDH.

#### 2.9.8 ON-BOARD OPERATIONAL INTERFACE WITH DMS

The following sections describe in general terms the operational interface between payload units and the DMS.



**2.9.8.1 Telecommand**

MIRO will receive commands sent from the ground or generated within the DMS. MIRO will be capable of receiving the commands at 131K bits per second MIRO will support a maximum data volume of 1024 bytes within a 0.2 second period.

**2.9.8.2 Telemetry**

Data of different types will be collected and are as follows:

**1. Housekeeping Data**

MIRO science housekeeping packet will contain those channels that will indicate the instrument's health, provide data to determine instrument's operating temperatures and its operation modes. The MIRO science housekeeping packets will contain verification of commands received.

**2. Science Data**

MIRO will provide both the science and science housekeeping to the S/C over a common interface. The MIRO analogue channels will be converted to housekeeping channel.

**3. Large Data File Transfer**

The DMS shall provide storage for data file to be used for MIRO program changes. Data rate and storage required are defined in EIDB Volume 6. This is based on MIRO operating out of RAM where initially program would be moved from EEPROM to RAM but if program is to be changed after launch, the new program would be uploaded to the DMS and then from the DMS to MIRO

## **3 EXPERIMENT OPERATIONS**

### **3.1 OPERATING PRINCIPLES**

MIRO has four (4) major types of operations during the Rosetta Mission:

1. Warmup of CTS and USO
2. Functional Tests
3. In-Flight Calibration Observations
4. Primary Scientific Observations

#### **3.1.1 INSTRUMENT POWER ON, WARMUP, AND STABILIZATION**

Two parts of the MIRO instrument require a warmup period to stabilize their electronics for in spec performance. These are the Chirp Transform Spectrometer (CTS), an assembly of the Electronics Unit, and the Ultra-Stable Oscillator (USO) Unit. During this warmup period, these components require power above their nominal operating state. To minimize the impact of this additional power need, the instrument power switches are configured such that most other MIRO components are off. The warmup sequence is performed automatically at instrument turn on and requires about 30 minutes for the CTS and at least 4 hours for the USO. MIRO may begin operations (acquisition of data) after the CTS warmup with the realization that the USO may not be completely stable and analysis will have higher error bars. Note that spectroscopic data acquired before the CTS is fully warmed up have a high risk of being completely meaningless.

#### **3.1.2 FUNCTIONAL TESTS**

The functional tests will turn on and functionally check out the instrument after any prolonged period during the mission in which the instrument has been turned off. Such periods include the launch and cruise phases of the mission. These tests consist of turning on the instrument such that all types of data are collected (engineering, continuum and spectroscopic) and commanding several parameter changes in order to ascertain the health and status of the instrument.

#### **3.1.3 IN-FLIGHT CALIBRATION OBSERVATIONS**

MIRO will need to perform in-flight calibrations periodically during the mission to check the absolute frequency response. During these observations, MIRO will point at various celestial sources, including Venus, Jupiter, Mars (at a distance) and (Galactic) instellar molecular clouds as well as MIRO's internal "hot" and "cold" targets. Table 3.1.3-1 contains a summary of the calibration goals during the mission and Table 3.1.3-2 prioritizes them. Details of the calibrations are described in section 3.2 of this document.

**Table 3.1.3-1: MIRO Calibration/Observing Needs**

Operation Phase	Modes Used (Ref: EID-B Table 6.3.1-1)	Targets							Calibration Attributes						
		Internal Loads	Earth	Moon	Mars	Celestial	Asteroid	Comet	Beam	Radiometer	Frequency	Spectrometer	Limb	Mapping	Boresighting
Launch phase	H	-	-	-	-	-	-	-	-	-	-	-	-	-	-
Commissioning-1	[1-17]	C	C	C	-	C	-	-	C	C	C	C	C	C	C
Cruise phase 1	[1-6], H	-	-	-	-	C	-	-	C	C	-	-	-	-	C
Commissioning-2	[1-17]	C	C	C	-	C	-	-	C	C	C	C	C	C	C
Earth flyby 1	[1-6], [13-4]	C	C	C	-	-	-	-	C	C	C	C	C	-	C
Cruise phase 2	H	-	-	-	-	-	-	-	-	-	-	-	-	-	-
Mars flyby	[1-6], [13-4]	-	-	-	C	-	-	-	C	C	C	C	-	-	C
Cruise phase 3	H	-	-	-	-	-	-	-	-	-	-	-	-	-	-
Earth flyby 2	[1-6], [13-4]	C	C	C	-	-	-	-	C	C	C	C	C	-	C
Cruise phase 4-1	H	-	-	-	-	-	-	-	-	-	-	-	-	-	-
Steins flyby	[1-6], [13-4]	C	-	-	-	-	S	-	C	C	-	-	-	C	C
Cruise phase 4-2	H	-	-	-	-	-	-	-	-	-	-	-	-	-	-
Earth flyby 3	[1-6], [13-4]	C	C	C	-	-	-	-	C	C	C	C	C	-	C
Cruise phase 5	H	-	-	-	-	-	-	-	-	-	-	-	-	-	-
DSHM Commissioning	H	-	-	-	-	-	-	-	-	-	-	-	-	-	-
Lutetia flyby	[1-6], [13-4]	C	-	-	-	-	S	-	C	C	-	-	-	C	C
Cruise phase 6 (DSHM)	H	-	-	-	-	-	-	-	-	-	-	-	-	-	-
Comet drift phase	[1-6], [13-14], [15], [16]	C	-	-	-	-	-	S	-	C	-	-	-	-	C
Far approach	[1-6], [7-12], [13,14], [15], [16]	C	-	-	-	-	-	S	-	C	-	-	-	-	C
Close approach	[1-6], [7-12], [13,14], [15], [16]	C	-	-	-	-	-	S	-	C	-	-	-	-	-
Transition to global mapping	[1-6], [7-12], [13,14], [15], [16]	C	-	-	-	-	-	S	-	C	-	-	-	-	-
Nucleus map./close enc.	[1-6], [7-12], [13,14], [15], [16]	C	-	-	-	-	-	S	-	C	-	-	-	-	-
Comet low activity phase	[1-6], [7-12], [13,14]	C	-	-	-	-	-	S	-	C	-	-	-	-	-
Comet activity: moderate increase	[1-6], [7-12]	C	-	-	-	-	-	S	-	C	-	-	-	-	-
Comet activity: sharp increase	[1-6], [7-12]	C	-	-	-	-	-	S	-	C	-	-	-	-	-
Comet activity: high activity	[1-6], [7-12]	C	-	-	-	-	-	S	-	C	-	-	-	-	-
Near perihel phase	[1-6]	C	-	-	-	-	-	S	-	C	-	-	-	-	-
Extended mission	TBD	-	-	-	-	-	-	-	-	-	-	-	-	-	-

Notes:

1. C (calibration) and S (science) refer to primary purpose of the observations;
2. Target sources may either be used for calibration or science; celestial sources include Venus, Jupiter, Mars (at a distance) and (Galactic) interstellar molecular clouds

**Table 3.1.3-2: Calibration Priorities (1 = highest)**

Calibration Elements				
	Moon	Earth	Mars	Celestial
Field of View (beam)	1	2	3	4
Radiometric (power)	1	2	3	4
Frequency (knowledge)	x	2	1	3
Spectrometer (function)	x	2	1	3

**3.1.3.1 Radiometric**

The principal radiometric calibration opportunity is the close observation of the Moon during the Earth swing-bys. MIRO continuum maps will be compared to detailed Moon models in order to perform the calibration.

**3.1.3.2 Frequency**

Opportunities for frequency calibration of the CTS will occur with nearby observations of Mars and Earth, in which several known spectral lines will be observed with high accuracy.

**3.1.3.3 Field of View**

Calibration of the FOV and offset of the MIRO beams requires a target that is bright enough to give a strong signal in the continuum detectors and distant enough to be of an angular size much less than the beamwidths. The best candidate for this is the Earth, well away from the swing-bys.

**3.1.4 PRIMARY SCIENTIFIC OBSERVATIONS**

MIRO will acquire science data during the Asteroid Flybys and during Comet Approach, Mapping and Close Encounter, and and Escort to Perihelion phases, as well as for targets (typically comets) of opportunity. Continuum, spectroscopic and calibration data will be taken during these times. These primary operating modes of MIRO are described in Section 6.1.2.1.1 of this User Manual.

Table 3.1.3-1 summarizes when science observations with MIRO will occur. Section 3.2 of this document describes in more detail, the types of data acquired during these phases.

Some special modes are described in the next section.

**3.1.4.1 Asteroid Mode**

A special mode was designed for the asteroid encounters, in which a large amount of spectroscopic data are acquired in a short period of time (maximum 18 minutes) and then played back during several hours after that. When using this mode, care must be taken in the observation design to allow sufficient time after

the primary observations to play back all the data, including as much of the post-asteroid mode data as are desired.

Note that this mode is not necessarily limited to use in asteroid encounters. It can also be of use in any close encounter with a target.

The Asteroid Mode telecommand is described in Section 6.1.2.2 of this User Manual.

### **3.1.5 MIRO FLIGHT COMPUTER MEMORY OPERATIONS**

The MIRO flight software is capable of being patched with updates from the ground. This capability has been tested before launch; however, the procedure for doing this in flight has yet to be worked out.

It should be noted that due to a bug, the Memory Checksum command in the MIRO flight software only includes every other memory location in the checksum, i.e., half the total memory requested. Therefore, in order to ensure that the EEPROM has not suffered any radiation damage, it is necessary to dump the entire area and perform the check on the ground.

### **3.1.6 THERMAL OPERATING LIMITS**

The principal thermal concern is overheating of the Gunn oscillators in the mm-wave and submm-wave heterodyne receivers mounted on the optical bench in the Sensor Unit, which may cause degradation of the longevity of some components. Therefore, we require that the instrument be switched off if the Optical Bench temperature exceeds 45 degrees C.

### **3.1.7 OPTIMIZING DATA TAKING**

Certain commands are designed to optimize the efficiency and stability of data acquisition. These include the Calibration Heater command, the CTS Runtime command, which controls the “CTS gap” and the Housekeeping Cycle Skip command.

#### **3.1.7.1 Calibration Heater**

There are two calibration loads in the MIRO instrument, one internal to the Sensor Unit and one mounted externally under the primary mirror of the telescope. The MIRO instrument is radiometrically calibrated by correlating its measured response when looking at each of the calibration loads with their physical temperature. For this calibration to be accurate, the difference in the two loads' temperature should be greater than 30C. The cold load will be at the temperature of the external environment. This is expected to become quite cold when the Rosetta spacecraft is far from the sun. The warm load is at the ambient temperature inside the spacecraft maintained between -20C and +50C. The purpose of the calibration heater is increase the temperature of the warm load should the two loads be within 30C of each other. The calibration heater

command, when turned on supplies current to a heater on the warm calibration load. With this current applied the warm load heats up about 30C above its ambient temperature. When the calibration heater is turned off, the warm load temperature returns to ambient.

The Calibration Heater telecommand is described in Section 6.1.1.1 of this User Manual.

### **3.1.7.2 CTS Gap**

In modes where both CTS and continuum data are being acquired, the CTS gap is the time between the end of the readout of a given continuum packet and the start of the next CTS scan. Reducing this gap increases the speed of data generation; however, it must not be so small that the CTS scan and the continuum readout overlap, as this will cause an instrument failure (power-off). The value of the gap is reported in the Miscellaneous Science packets, and it can be changed by varying the parameters of the CTS Runtime command, which sets the duration of a CTS scan.

The CTS Runtime telecommand is described in Section 6.1.5.8 of this User Manual.

### **3.1.7.3 Housekeeping Cycle Skip**

The digital noise generated when reading the engineering housekeeping data every 11 seconds can cause excess noise in the continuum data. The engineering housekeeping cycle skip command can be used to skip this readout for a certain period of time in order to eliminate this noise source.

The Housekeeping Cycle Skip telecommand is described in Section 6.1.3.1 of this User Manual.

## **3.2 OPERATING MODES**

### **3.2.1 GROUND TEST PLAN**

The ground test plan for MIRO, both EQM and FM includes tests for electrical and functional verification including the spacecraft interfaces and a full set of environmental tests (vibration, shock, thermal / vacuum and EMC). Tests that will be performed on the flight model which are not performed on the EQM are optical alignment tests and detailed calibration tests. In addition, the MIRO STM performed qualification level vibration testing of each unit.

For functional and interface verifications (not including the detailed electrical verification and EMC test), a set of test sequences are defined (see Attachment 4 of this document). The following tests are defined:

- Full Functional Test (FFT)
- Bench Test (BT)

- Unit Functional Test (UFT)
- Integrated System Test (IST)
- Special Performance Test (SPT)

### 3.2.2 IN-ORBIT COMMISSIONING PLAN (MIRO EID-B, § 6.3.2.2)

MIRO will initially undergo a checkout procedure during the commissioning phase, followed by tests to establish baseline performance of the instrument. MIRO will run through its operational modes, and will provide calibration and housekeeping data. As an essential part of 1) the instrument pointing and alignment, and 2) the radiometric calibration of both the millimeter and sub-millimeter-wave receivers, the MIRO instrument will observe the Moon, the Earth and Celestial sources (Venus, Jupiter, Mars or Galactic) as available. Observations will be required at times which are not tightly constrained (within a 10 day period TBC). Two sets of observations are desired; one set preferably timed to be late in the commissioning period when the Earth or Moon are smaller than the smallest MIRO beamwidth (7 arc min), and a second set when either source is large relative to the MIRO beamwidths so that its limb may be scanned. The Moon is a valuable source for gain calibration because it was extensively observed by the Cosmic Microwave Background Explorer and its microwave brightness temperature distribution is well understood. Observations of the Moon when it is smaller than the MIRO beamwidth will enable the verification of the antenna on-axis gain to within approximately 2%. Observations when the Moon is larger than the beamwidth will enable the verification of the main beam efficiency and will enhance confidence in our ability to determine absolute brightness temperatures of the comet nucleus. These observations will require up to four hours each, (more time than when the Moon is smaller than a beamwidth) since mapping is required.

### 3.2.3 INSTRUMENT CHECKOUT

During the regular payload checkout activities, MIRO will run a standard sequence (AMRF100A, see FOP) in which as many modes and commands are exercised as possible. In addition, a dump of EEPROM memory (AMRF101A, see FOP) will be performed in order to check for radiation damage (see 3.1.5).

### 3.2.4 FLIGHT OPERATIONS PLANS (MIRO EID-B, § 6.3.2.3)

This section covers the post-launch operation of MIRO in conjunction with the overall operations of the Rosetta spacecraft. The MIRO science team will conduct its mission operations through the Rosetta Science Operations Centre (RSOC) as described below. The operations requirements for MIRO are given for all phases of the mission, from launch until the end of the mission, making use of the facilities provided to the MIRO team by ESOC. This portion of Volume VI is a response to Volume VI of the Rosetta EID-A and is to be read in that context.

Specifically, the Mission Operations description and definitions of terms appearing in that document are not repeated here.

The following sections describe the requirements of the MIRO instrument during the mission phases described in Section 6.2 of the EID-A.

#### **3.2.4.1 Launch Phase**

MIRO will be off during launch phase.

#### **3.2.4.2 Cruise Phases**

MIRO will generally be switched off during the cruise phases with the exception of the calibration periods and the periodic instrument checkouts.

#### **3.2.4.3 Mars Gravity Assist**

Mars observations in both the continuum and spectral modes are desired to obtain spectral calibration and confirmation of pointing parameters, to be obtained toward the end of the Mars Gravity Assist period after close encounter and before the apparent disk of Mars decreases below the MIRO beamwidths. Both centred (boresighted) and limb sounding observations are desired. The asteroid mode may be used for these observations.

#### **3.2.4.4 Earth Gravity Assists**

A minimal instrument turn-on and checkout procedure will be performed during these two phases. Further, Earth observations in spectral modes are desired to confirm spectral calibration. Observations of the Earth and Moon in continuum mode are desired to determine pointing parameters and establish gain calibrations. It is desired that these observations be obtained toward the end of the Earth Gravity Assist periods (as with the Mars fly-by).

#### **3.2.4.5 Steins Fly-by**

The flyby of Steins is the first opportunity for science observations by MIRO, which will be turned on and fully operational during this phase. Continuum radiometry and sub-millimeter spectroscopy will be performed during this flyby, via the asteroid mode, to search for low levels of gas (water) and evaluate the state of rotation of the asteroid.

#### **3.2.4.6 Lutetia Fly-by**

MIRO operations at Lutetia will be the same as those for Steins.

#### **3.2.4.7 Deep Space Hibernation Mode (DSHM)**

MIRO will remain switched off during this phase.



**3.2.4.8 Rendezvous Manoeuvre**

MIRO will remain switched off during this phase.

**3.2.4.9 Comet Drift Phase**

A minimal instrument turn-on and checkout procedure will be performed during this phase. A brief period of comet nucleus observation comparable to those of the asteroids is desired depending on available spacecraft resources; otherwise the instrument will remain switched off through most of this phase.

**3.2.4.10 Comet Approach Navigation and Manoeuvring**

MIRO will be turned on and fully operational during this and all subsequent phases.

**3.2.4.11 Nucleus Mapping and Close Observation**

MIRO will operate primarily in continuum mode during this phase and will support the mission's nucleus characterisation effort. By mapping the area near the lander the surface emissivity can be characterised using in situ temperature measurements from the lander. If power is available, spectroscopic mode will be used as well.

**3.2.4.12 SSP Delivery and Comet Escort to Perihelion**

Observations during this phase are MIRO's prime mission objective. MIRO will operate in all modes, and will observe the nucleus in both continuum and spectroscopic modes with as large a range of solar phase angles as possible, and will observe the coma in all possible directions from the spacecraft relative to the nucleus.

**3.2.5 INTERFERENCES**

At the present time, no interferences between MIRO and other instruments or subsystems have been definitely established, although disturbances are occasionally seen in the data that could be due to some sort of interference. It is intended to perform further analysis in order to settle this issue. Also, the following is a candidate for possible interference and should be closely monitored during MIRO operations:

- Thrusters firing. MIRO should be turned off when this occurs.

### 3.2.6 OPERATIONAL CONSTRAINTS

The following operational constraints exist for MIRO:

1. Instrument constraints related to warming up (see 3.1.10):
  - It is imperative that CTS warmup be started at least 30 minutes before the CTS is turned on; if this is not done, there is a high probability that the CTS data will be invalid.
  - It is desirable that the USO be stable during CTS operations, but since full stabilization can take 8 hours (or more), it is permissible to start the CTS soon after CTS warmup has been performed (above), with the realization that the data will have higher noise than after stabilization has been achieved. Normally, the USO should be turned on at least 2 hours before the CTS is started up.
2. Commanding constraints. The following constraints exist on the instrument commands that switch various modules on and off:
  - USO: cannot be powered off from any CTS mode; otherwise, it can be powered on or off from any mode.
  - MM LNA: this is powered on automatically when MIRO goes into MM Continuum, Dual Continuum and CTS/Dual Continuum modes. It can be powered on or off in these modes only, not in any other mode. It can only be powered on after it has been powered off without a mode change.
  - SMM LNA: same as MM LNA, with the substitution of SMM for MM.
  - CTS Warmup: this command can only be issued from a non-CTS mode; the CTS warmup is automatically switched off by any mode change to a non-CTS mode, and this is the only way in which it can be turned off.
  - CTS Heater: this command can only be issued from a CTS mode. Note that the CTS heater is turned on automatically when any CTS mode is entered, but the temperature and heating rate are then set to default values.
3. Pointing constraint: the MIRO boresight shall not be closer than 5 degrees from the Sun.
4. Power constraint: there is a latching current limit (LCL) of 109W / 4A. (Ref.: EID-B section 2.4.1, Table 2.4-1.)
5. Thermal constraint: the Optical Bench temperature should not exceed 45 degrees C; if this is exceeded, MIRO should be turned off. (See 3.1.6.)
6. Interferences (See 3.2.5): until further tests have determined that there is no interference from the thrusters, MIRO should avoid being on when the thrusters are firing.

### 3.3 FAILURE DETECTION AND RECOVERY STRATEGY

The MIRO instrument is a single string instrument. Accordingly, there is little that can be done in the event of a major instrument failure. Table 3.3-1 summarizes the possible failure modes and describes the consequences of each. Also refer to EID-B §6.5.4 for recovery procedures.

In order to prevent the instrument temperatures from rising to excessively high values during observations in which there is no ground contact with the spacecraft for extensive periods, there is an on-board monitoring procedure on the Optical Bench temperature (NTSA0194), which will turn off MIRO by OBCP if this item exceeds 45 degrees C for more than 30 consecutive seconds.

**Table 3.3-1: MIRO Failure Modes and Possible Recovery Operations**

Assembly/ Subassembly	Failure	Response
Mirror Motor	Complete failure to operate	Activate the pin puller mechanism which will disengage the mirror from the motor. Once disengaged, the spring loaded mirror will move to the "Space" position. Calibration target data will be lost
Mirror LEDs for positioning	Failure to indicate position	Error codes returned in anomaly packets need to be analyzed to determine if this failure is permanent. If permanent failure, only recovery is to re-write flight software to count steps to each calibration target position.
mm-receiver	Failure of component	May be able to bring component back into operation by changing operating parameter. Worse case is complete loss of mm continuum data.
Submm-receiver	Failure of component	May be able to bring component back into operation by changing various operating parameters. Worse case is complete loss of submm continuum data and all spectroscopic data.
Signal processing electronics	Failure of key component	Depending on component that fails, may be recoverable via operating parameters. Some data loss will happen.
Main electronics	Failure of key component	Depending on component that fails, may be recoverable via operating parameters. Some data loss will happen.
Power Controller Electronics	Failure of DC/DC Converter	Depending on which power converter fails, some recovery is possible
Failure of CPU	Failure of electronics	Not recoverable
Failure of CTS	Failure of electronics	Loss of spectroscopic data

## 4 MODE DESCRIPTIONS

The MIRO instrument has 6 major modes: engineering mode, millimeter-wave continuum mode, submillimeter-wave continuum mode, dual continuum mode, CTS/submillimeter-wave continuum mode, and CTS/dual continuum mode. Each of these modes has different power levels. The data rate for a given mode is dependent on the parameters selected. Each mode and its data rate are discussed in more detail below. The parameters for each mode are described in more detail in Volume 6.1 Telecommand Description.

As per the EID-A, when the instrument is initially powered on it will enter engineering mode upon receipt of a time update telecommand from the spacecraft. Engineering mode telemetry will be sent to the spacecraft within 1 minute following the time synchronization telecommand.

### 4.1 ENGINEERING MODE

While running in engineering mode the MIRO software is collecting engineering data from 56 internal sensors. The sampling of these sensors is at a 5 Hz rate. All engineering measurements are 12-bit A/D converted values. The engineering mode telemetry is sent to the spacecraft in the form of a housekeeping telemetry packet. One engineering telemetry packet is generated every 11 seconds, unless the Engineering Housekeeping Cycle Skip Telecommand has been executed with its parameter set to n not equal to zero. Then the telemetry packet is returned every  $(n+1)*11$  seconds.

The engineering TM is also generated all the other MIRO operational modes.

### 4.2 MILLIMETER CONTINUUM MODE

While running in millimeter continuum mode the MIRO software has powered up the millimeter continuum portion of the electronics. Millimeter continuum data is collected at a 20 Hz. rate. All continuum data consist of 16-bit values. The millimeter continuum data is nominally packet into science telemetry packets every 10 seconds. A 'summing value' parameter can cause the MIRO software to sum either 1, 2, 5, 10, or 20 separate continuum values prior to putting them into the telemetry packet. This feature can reduce the data rate to as little as one millimeter continuum packet every 200 seconds.

### 4.3 SUB-MILLIMETER CONTINUUM MODE

Sub-millimeter continuum mode is very similar to millimeter continuum mode except a different set of electronics is powered on. The data collection and packing is identical to millimeter continuum mode. Millimeter and sub-millimeter continuum data are contained in separate science telemetry packets. A field in the source data header identifies which type of science data is contained in the telemetry packet.

#### 4.4 DUAL CONTINUUM MODE

In dual continuum mode the millimeter and sub-millimeter continuum are being collected simultaneously. When running in dual continuum mode, the summing value parameter mentioned earlier is applied to both sets of data. This causes the same amount of millimeter and sub-millimeter data to be generated.

#### 4.5 CTS / SUB-MILLIMETER CONTINUUM MODE

This mode adds the collection of chirp transform spectrometer (CTS) data. The CTS is programmed by the MIRO software to run for an initial sub-integration period of approximately 5 seconds. An internal LO frequency generator is then switched and another 5 second period is observed. These pairs of observations are repeated with the respective results being summed over time. Selectable integration periods are 30, 60, 90, and 120 seconds. The data from the 2 LO frequencies are then subtracted from each other.

The CTS returns a total of 4096 channels of data. The 4096 data values can be further reduced by application of a smoothing function whereby data from several channels are combined and weighted to produce fewer final channels. Smoothing window sizes are 1, 5, 7 and 9 channels. A mask is applied to the CTS data and only 12 bits of each resulting measurement is returned.

CTS data collection and the LO frequency switching is coordinated with the collection of continuum data. Exactly 100 continuum samples are taken during each CTS scan. Upon receipt of the data on the ground it is known at which LO frequency all of the continuum measurements were made at.

If the CTS has just been powered on an internal calibration of the CTS is performed. This consists of loading the 4 CTS sum of square tables with a linear ramping pattern. A 10,000 cycle integration is then performed and the resulting data read out. The data is then averaged to yield the mid-point of the table. The resulting mid-point values for each table are downlinked in telemetry packets for monitoring over time.

#### 4.6 CTS / DUAL CONTINUUM MODE

This is similar to CTS / SMM continuum mode except that the millimeter data is also collected.

#### 4.7 MODE TRANSITIONS

It is possible to change the software operating mode from/to any valid mode. A mode change command is issued to the MIRO software. The mode change command contains 4 controlling parameters:

1. Power mode (the 6 defined above)
2. CTS integration period (30, 60, 90 or 120 seconds)

3. CTS smoothing value
4. Continuum summing value (1, 2, 5, 10 or 20)

The process of changing from one operational mode to another is begun via a graceful shutdown of the current mode. If the CTS is running as part of the current mode, then the current CTS integration period is allowed to complete. The telemetry data associated with the current scan, as well as the accumulating continuum data, are then flushed out. The software is then shut down.

If the CTS is not operating then the graceful shutdown is much simpler. If continuum data is being collected then the current 5 second ( $\leq 100$  samples, dependent on summing value) collection cycle is allowed to complete prior to shutting down the software. If engineering mode is the current mode then no graceful shutdown is required as engineering collection continues through all mode transitions.

After the graceful software shutdown is complete, any required power state changes are made. This could result in numerous components either being powered on or off depending on the current mode and the commanded mode.

The start of each mode, except for engineering only mode, begins with an instrument calibration. The instrument calibration views the hot target for 30 seconds, the cold target for 30 seconds, and finally the space target for 30 seconds. CTS data collected during calibration is not subtracted based on LO frequency. Both LO data sets are returned. The continuum summing value in place when the mode is changed controls the rate of continuum collection during the instrument calibration.

When the instrument calibration is complete the nominal processing mode is begun. The MIRO instrument will remain in nominal processing until it receives a mode change command or approximately 30 minutes have elapsed. After 30 minutes another instrument calibration is performed. Instrument calibration is performed with every mode change and every 30 minutes except when running in engineering only mode.

## 4.8 DATA RATES WITHIN MODES

Depending on all the parameters specified in the mode change command the MIRO software can generate a variety of telemetry data rates in the different power modes. Nearly all MIRO telemetry packets have been designed to be 430 bytes in size. Collected telemetry data is then trickled out over time depending on the allowable data rate. The rate is specified as a fixed number (maximum) of 430 byte telemetry packets to be sent by the MIRO software to the spacecraft every 8 seconds. The net result is that MIRO has a total of 17 operation modes when you define mode to be a combination of power and data rate.

**4.8.1 CTS DUAL CONTINUUM MODE**

Housekeeping On/Off	# of Summed 50-msec Continuum-mm Integrations	# of Summed 50-msec Continuum-smm Integrations	CTS Integration Time	CTS Smoothing Shift	HK Rate (bps)	CON/mm Rate (bps)	CON/smm Rate (bps)	CTS Rate (bps)	CTS Rate Including Calibration (bps)	Overall Rate (bps)	Overall + 3.72% Packet Overhead (bps)	Data Mode
1	1	1	31.2	1	60	320	320	1577	1636	2336	2423	6
1	1	1	31.2	2	60	320	320	795	899	1599	1658	5
1	1	1	31.2	3	60	320	320	526	645	1345	1395	4
1	1	1	31.2	4	60	320	320	395	521	1221	1266	4
1	1	1	62.4	1	60	320	320	789	893	1593	1652	5
1	1	1	62.4	2	60	320	320	398	525	1225	1270	4
1	1	1	62.4	3	60	320	320	264	398	1098	1138	3
1	1	1	62.4	4	60	320	320	198	336	1036	1074	3
1	1	1	93.6	1	60	320	320	527	645	1345	1396	4
1	1	1	93.6	2	60	320	320	266	400	1100	1141	3
1	1	1	93.6	3	60	320	320	176	315	1015	1053	3
1	1	1	93.6	4	60	320	320	133	274	974	1010	3
1	1	1	124.8	1	60	320	320	395	522	1222	1267	4
1	1	1	124.8	2	60	320	320	200	337	1037	1076	3
1	1	1	124.8	3	60	320	320	133	274	974	1010	3
1	1	1	124.8	4	60	320	320	100	243	943	978	3
1	2	2	31.2	1	60	160	160	1577	1636	2016	2091	6
1	2	2	31.2	2	60	160	160	795	899	1279	1326	4
1	2	2	31.2	3	60	160	160	526	645	1025	1063	3
1	2	2	31.2	4	60	160	160	395	521	901	934	3
1	2	2	62.4	1	60	160	160	789	893	1273	1320	4
1	2	2	62.4	2	60	160	160	398	525	905	938	3
1	2	2	62.4	3	60	160	160	264	398	778	807	3
1	2	2	62.4	4	60	160	160	198	336	716	742	2
1	2	2	93.6	1	60	160	160	527	645	1025	1064	3
1	2	2	93.6	2	60	160	160	266	400	780	809	3
1	2	2	93.6	3	60	160	160	176	315	695	721	2
1	2	2	93.6	4	60	160	160	133	274	654	678	2

**4.8.1 CTS DUAL CONTINUUM MODE (CONTINUED)**

Housekeeping On/Off	# of Summed 50-msec Continuum-mm Integrations	# of Summed 50-msec Continuum-smm Integrations	CTS Integration Time	CTS Smoothing Shift	HK Rate (bps)	CON/mm Rate (bps)	CON/smm Rate (bps)	CTS Rate (bps)	CTS Rate Including Calibration (bps)	Overall Rate (bps)	Overall + 3.72% Packet Overhead (bps)	Data Mode
1	2	2	124.8	1	60	160	160	395	522	902	935	3
1	2	2	124.8	2	60	160	160	200	337	717	744	2
1	2	2	124.8	3	60	160	160	133	274	654	678	2
1	2	2	124.8	4	60	160	160	100	243	623	646	2
1	5	5	31.2	1	60	64	64	1577	1636	1824	1892	5
1	5	5	31.2	2	60	64	64	795	899	1087	1127	3
1	5	5	31.2	3	60	64	64	526	645	833	864	3
1	5	5	31.2	4	60	64	64	395	521	709	735	2
1	5	5	62.4	1	60	64	64	789	893	1081	1121	3
1	5	5	62.4	2	60	64	64	398	525	713	739	2
1	5	5	62.4	3	60	64	64	264	398	586	607	2
1	5	5	62.4	4	60	64	64	198	336	524	543	2
1	5	5	93.6	1	60	64	64	527	645	833	864	3
1	5	5	93.6	2	60	64	64	266	400	588	610	2
1	5	5	93.6	3	60	64	64	176	315	503	522	2
1	5	5	93.6	4	60	64	64	133	274	462	479	2
1	5	5	124.8	1	60	64	64	395	522	710	736	2
1	5	5	124.8	2	60	64	64	200	337	525	545	2
1	5	5	124.8	3	60	64	64	133	274	462	479	2
1	5	5	124.8	4	60	64	64	100	243	431	447	2
1	10	10	31.2	1	60	32	32	1577	1636	1760	1825	5
1	10	10	31.2	2	60	32	32	795	899	1023	1061	3
1	10	10	31.2	3	60	32	32	526	645	769	798	2
1	10	10	31.2	4	60	32	32	395	521	645	669	2
1	10	10	62.4	1	60	32	32	789	893	1017	1055	3
1	10	10	62.4	2	60	32	32	398	525	649	673	2
1	10	10	62.4	3	60	32	32	264	398	522	541	2
1	10	10	62.4	4	60	32	32	198	336	460	477	2



**4.8.1 CTS DUAL CONTINUUM MODE (CONTINUED)**

Housekeeping On/Off	# of Summed 50-msec Continuum-mm Integrations	# of Summed 50-msec Continuum-smm Integrations	CTS Integration Time	CTS Smoothing Shift	HK Rate (bps)	CON/mm Rate (bps)	CON/smm Rate (bps)	CTS Rate (bps)	CTS Rate Including Calibration (bps)	Overall Rate (bps)	Overall + 3.72% Packet Overhead (bps)	Data Mode
1	10	10	93.6	1	60	32	32	527	645	769	798	2
1	10	10	93.6	2	60	32	32	266	400	524	543	2
1	10	10	93.6	3	60	32	32	176	315	439	455	2
1	10	10	93.6	4	60	32	32	133	274	398	413	2
1	10	10	124.8	1	60	32	32	395	522	646	670	2
1	10	10	124.8	2	60	32	32	200	337	461	479	2
1	10	10	124.8	3	60	32	32	133	274	398	413	2
1	10	10	124.8	4	60	32	32	100	243	367	381	1
1	20	20	31.2	1	60	16	16	1577	1636	1728	1792	5
1	20	20	31.2	2	60	16	16	795	899	991	1028	3
1	20	20	31.2	3	60	16	16	526	645	737	764	2
1	20	20	31.2	4	60	16	16	395	521	613	636	2
1	20	20	62.4	1	60	16	16	789	893	985	1022	3
1	20	20	62.4	2	60	16	16	398	525	617	640	2
1	20	20	62.4	3	60	16	16	264	398	490	508	2
1	20	20	62.4	4	60	16	16	198	336	428	443	2
1	20	20	93.6	1	60	16	16	527	645	737	765	2
1	20	20	93.6	2	60	16	16	266	400	492	510	2
1	20	20	93.6	3	60	16	16	176	315	407	422	2
1	20	20	93.6	4	60	16	16	133	274	366	379	1
1	20	20	124.8	1	60	16	16	395	522	614	636	2
1	20	20	124.8	2	60	16	16	200	337	429	445	2
1	20	20	124.8	3	60	16	16	133	274	366	380	1
1	20	20	124.8	4	60	16	16	100	243	335	347	1

**4.8.2 CTS/ SMM CONTINUUM MODE**

Housekeeping On/Off	# of Summed 50-msec Continuum-mm Integrations	# of Summed 50-msec Continuum-smm Integrations	CTS Integration Time	CTS Smoothing Shift	HK Rate (bps)	CON/mm Rate (bps)	CON/smm Rate (bps)	CTS Rate (bps)	CTS Rate Including Calibration (bps)	Overall Rate (bps)	Overall + 3.72% Packet Overhead (bps)	Data Mode
1	0	1	31.2	1	60	0	320	1577	1636	2016	2091	6
1	0	1	31.2	2	60	0	320	795	899	1279	1326	4
1	0	1	31.2	3	60	0	320	526	645	1025	1063	3
1	0	1	31.2	4	60	0	320	395	521	901	934	3
1	0	1	62.4	1	60	0	320	789	893	1273	1320	4
1	0	1	62.4	2	60	0	320	398	525	905	938	3
1	0	1	62.4	3	60	0	320	264	398	778	807	3
1	0	1	62.4	4	60	0	320	198	336	716	742	2
1	0	1	93.6	1	60	0	320	527	645	1025	1064	3
1	0	1	93.6	2	60	0	320	266	400	780	809	3
1	0	1	93.6	3	60	0	320	176	315	695	721	2
1	0	1	93.6	4	60	0	320	133	274	654	678	2
1	0	1	124.8	1	60	0	320	395	522	902	935	3
1	0	1	124.8	2	60	0	320	200	337	717	744	2
1	0	1	124.8	3	60	0	320	133	274	654	678	2
1	0	1	124.8	4	60	0	320	100	243	623	646	2
1	0	2	31.2	1	60	0	160	1577	1636	1856	1925	5
1	0	2	31.2	2	60	0	160	795	899	1119	1161	3
1	0	2	31.2	3	60	0	160	526	645	865	897	3
1	0	2	31.2	4	60	0	160	395	521	741	769	2
1	0	2	62.4	1	60	0	160	789	893	1113	1154	3
1	0	2	62.4	2	60	0	160	398	525	745	772	2
1	0	2	62.4	3	60	0	160	264	398	618	641	2
1	0	2	62.4	4	60	0	160	198	336	556	576	2
1	0	2	93.6	1	60	0	160	527	645	865	898	3
1	0	2	93.6	2	60	0	160	266	400	620	643	2
1	0	2	93.6	3	60	0	160	176	315	535	555	2
1	0	2	93.6	4	60	0	160	133	274	494	512	2

**4.8.2 CTS/ SMM CONTINUUM MODE (CONTINUED)**

Housekeeping On/Off	# of Summed 50-msec Continuum-mm Integrations	# of Summed 50-msec Continuum-smm Integrations	CTS Integration Time	CTS Smoothing Shift	HK Rate (bps)	CON/mm Rate (bps)	CON/smm Rate (bps)	CTS Rate (bps)	CTS Rate Including Calibration (bps)	Overall Rate (bps)	Overall + 3.72% Packet Overhead (bps)	Data Mode
1	0	2	124.8	1	60	0	160	395	522	742	769	2
1	0	2	124.8	2	60	0	160	200	337	557	578	2
1	0	2	124.8	3	60	0	160	133	274	494	512	2
1	0	2	124.8	4	60	0	160	100	243	463	480	2
1	0	5	31.2	1	60	0	64	1577	1636	1760	1825	5
1	0	5	31.2	2	60	0	64	795	899	1023	1061	3
1	0	5	31.2	3	60	0	64	526	645	769	798	2
1	0	5	31.2	4	60	0	64	395	521	645	669	2
1	0	5	62.4	1	60	0	64	789	893	1017	1055	3
1	0	5	62.4	2	60	0	64	398	525	649	673	2
1	0	5	62.4	3	60	0	64	264	398	522	541	2
1	0	5	62.4	4	60	0	64	198	336	460	477	2
1	0	5	93.6	1	60	0	64	527	645	769	798	2
1	0	5	93.6	2	60	0	64	266	400	524	543	2
1	0	5	93.6	3	60	0	64	176	315	439	455	2
1	0	5	93.6	4	60	0	64	133	274	398	413	2
1	0	5	124.8	1	60	0	64	395	522	646	670	2
1	0	5	124.8	2	60	0	64	200	337	461	479	2
1	0	5	124.8	3	60	0	64	133	274	398	413	2
1	0	5	124.8	4	60	0	64	100	243	367	381	1
1	0	10	31.2	1	60	0	32	1577	1636	1728	1792	5
1	0	10	31.2	2	60	0	32	795	899	991	1028	3
1	0	10	31.2	3	60	0	32	526	645	737	764	2
1	0	10	31.2	4	60	0	32	395	521	613	636	2
1	0	10	62.4	1	60	0	32	789	893	985	1022	3
1	0	10	62.4	2	60	0	32	398	525	617	640	2
1	0	10	62.4	3	60	0	32	264	398	490	508	2
1	0	10	62.4	4	60	0	32	198	336	428	443	2

**4.8.2 CTS/ SMM CONTINUUM MODE (CONTINUED)**

Housekeeping On/Off	# of Summed 50-msec Continuum-mm Integrations	# of Summed 50-msec Continuum-smm Integrations	CTS Integration Time	CTS Smoothing Shift	HK Rate (bps)	CON/mm Rate (bps)	CON/smm Rate (bps)	CTS Rate (bps)	CTS Rate Including Calibration (bps)	Overall Rate (bps)	Overall + 3.72% Packet Overhead (bps)	Data Mode
1	0	10	93.6	1	60	0	32	527	645	737	765	2
1	0	10	93.6	2	60	0	32	266	400	492	510	2
1	0	10	93.6	3	60	0	32	176	315	407	422	2
1	0	10	93.6	4	60	0	32	133	274	366	379	1
1	0	10	124.8	1	60	0	32	395	522	614	636	2
1	0	10	124.8	2	60	0	32	200	337	429	445	2
1	0	10	124.8	3	60	0	32	133	274	366	380	1
1	0	10	124.8	4	60	0	32	100	243	335	347	1
1	0	20	31.2	1	60	0	16	1577	1636	1712	1776	5
1	0	20	31.2	2	60	0	16	795	899	975	1011	3
1	0	20	31.2	3	60	0	16	526	645	721	748	2
1	0	20	31.2	4	60	0	16	395	521	597	619	2
1	0	20	62.4	1	60	0	16	789	893	969	1005	3
1	0	20	62.4	2	60	0	16	398	525	601	623	2
1	0	20	62.4	3	60	0	16	264	398	474	491	2
1	0	20	62.4	4	60	0	16	198	336	412	427	2
1	0	20	93.6	1	60	0	16	527	645	721	748	2
1	0	20	93.6	2	60	0	16	266	400	476	493	2
1	0	20	93.6	3	60	0	16	176	315	391	406	2
1	0	20	93.6	4	60	0	16	133	274	350	363	1
1	0	20	124.8	1	60	0	16	395	522	598	620	2
1	0	20	124.8	2	60	0	16	200	337	413	429	2
1	0	20	124.8	3	60	0	16	133	274	350	363	1
1	0	20	124.8	4	60	0	16	100	243	319	331	1

### 4.8.3 DUAL CONTINUUM MODE

Housekeeping On/Off	# of Summed 50-msec Continuum-mm Integrations	# of Summed 50-msec Continuum-smm Integrations	CTS Integration Time	CTS Smoothing Shift	HK Rate (bps)	CON/mm Rate (bps)	CON/smm Rate (bps)	CTS Rate (bps)	CTS Rate Including Calibration (bps)	Overall Rate (bps)	Overall + 3.72% Packet Overhead (bps)	Data Mode
1	1	1	N/A	N/A	60	320	320	0		700	726	2
1	2	2	N/A	N/A	60	160	160	0		380	394	1
1	5	5	N/A	N/A	60	64	64	0		188	195	1
1	10	10	N/A	N/A	60	32	32	0		124	129	1
1	20	20	N/A	N/A	60	16	16	0		92	95	1

### 4.8.4 SMM CONTINUUM MODE

Housekeeping On/Off	# of Summed 50-msec Continuum-mm Integrations	# of Summed 50-msec Continuum-smm Integrations	CTS Integration Time	CTS Smoothing Shift	HK Rate (bps)	CON/mm Rate (bps)	CON/smm Rate (bps)	CTS Rate (bps)	CTS Rate Including Calibration (bps)	Overall Rate (bps)	Overall + 3.72% Packet Overhead (bps)	Data Mode
1	0	1	N/A	N/A	60	0	320	0		380	394	1
1	0	2	N/A	N/A	60	0	160	0		220	228	1
1	0	5	N/A	N/A	60	0	64	0		124	129	1
1	0	10	N/A	N/A	60	0	32	0		92	95	1
1	0	20	N/A	N/A	60	0	16	0		76	79	1

**4.8.5 MM CONTINUUM MODE**

Housekeeping On/Off	# of Summed 50-msec Continuum-mm Integrations	# of Summed 50-msec Continuum-smm Integrations	CTS Integration Time	CTS Smoothing Shift	HK Rate (bps)	CON/mm Rate (bps)	CON/smm Rate (bps)	CTS Rate (bps)	CTS Rate Including Calibration (bps)	Overall Rate (bps)	Overall + 3.72% Packet Overhead (bps)	Data Mode
1	1	0	N/A	N/A	60	320	0	0		380	394	1
1	2	0	N/A	N/A	60	160	0	0		220	228	1
1	5	0	N/A	N/A	60	64	0	0		124	129	1
1	10	0	N/A	N/A	60	32	0	0		92	95	1
1	20	0	N/A	N/A	60	16	0	0		76	79	1

**4.8.6 ENGINEERING MODE**

Housekeeping On/Off	# of Summed 50-msec Continuum-mm Integrations	# of Summed 50-msec Continuum-smm Integrations	CTS Integration Time	CTS Smoothing Shift	HK Rate (bps)	CON/mm Rate (bps)	CON/smm Rate (bps)	CTS Rate (bps)	CTS Rate Including Calibration (bps)	Overall Rate (bps)	Overall + 3.72% Packet Overhead (bps)	Data Mode
1	0	0	N/A	N/A	60	0	0	0		60	62	1

## 5

**CONTINGENCY RECOVERY AND FLIGHT  
CONTROL PROCEDURES/SEQUENCES**

The following is a list of Contingency Recovery Procedures (CRP) and sequences, and Flight Control Procedures (FCP) and sequences for MIRO. This list is based on Issue 5.1 dated 26/07/2005. Details of procedures are contained in RO-ESC-PL-5000.

CRP-001 Emergency Switch-Off  
MR-FCP-001 MIRO Power On Engineering using OBCP  
MR-FCP-003 MIRO Power Off using OBCP  
MR-FCP-004 MIRO Power Off/Asteroid  
MR-FCP-007 MIRO Calibration Heater Power On  
MR-FCP-008 MIRO USO ON  
MR-FCP-009 MIRO CTS Warm-up  
MR-FCP-011 MIRO Mode Change to CTS/Dual Continuum  
MR-FCP-012 MIRO Mode Change to CTS/SMM  
MR-FCP-013 MIRO Mode Change to Dual Continuum  
MR-FCP-014 MIRO Mode Change to SMM Continuum  
MR-FCP-015 MIRO Mode Change to MM Continuum  
MR-FCP-016 MIRO Mode Change to Engineering  
MR-FCP-030 MIRO CTS Internal Calibration  
MR-FCP-031 MIRO MM LNA Power Off  
MR-FCP-032 MIRO SMM LNA Power Off  
MR-FCP-100 MIRO Instrument Checkout  
MR-FCP-101 MIRO EEPROM Memory Dump  
MR-FCP-200 MIRO Radio Source Boresight  
MR-FCP-210 MIRO Radiometric Calibration of the Moon  
MR-FCP-300 MIRO Point at Fixed Celestial Position  
MR-FCP-320 MIRO MAP/SCAN Object  
MR-FCP-500 MIRO Asteroid Observation  
MR-SEQ-301 Enable HK  
MR-SEQ-302 Disable HK  
MR-SEQ-402 Dump MIRO Memory

MR-SEQ-403 Check MIRO Memory  
MR-SEQ-601 Set Submm Gunn Voltage  
MR-SEQ-603 MM LNA Power  
MR-SEQ-604 Submm LNA Power  
MR-SEQ-605 MR IFP Power Control  
MR-SEQ-607 Reset PLL  
MR-SEQ-610 CTS Run Time  
MR-SEQ-611 CTS Pulse Position  
MR-SEQ-612 Move Mirror  
MR-SEQ-613 MIRO SW Restart  
MR-SEQ-614 MIRO Mode Change  
MR-SEQ-615 CTS Thermal Control Command  
MR-SEQ-617 MIRO CTS Data Masks  
MR-SEQ-618 Continuum Subtraction Value  
MR-SEQ-621 CTS Warmup  
MR-SEQ-622 USO Off  
MR-SEQ-623 SMM Gunn Voltage AutoCtrl Enable/Disable  
MR-SEQ-624 MIRO Engineering Data Slow Down  
MR-SEQ-631 Enable Science  
MR-SEQ-632 Disable Science  
MR-SEQ-722 Step Mirror



## 6 DATA OPERATIONS HANDBOOK (TELECOMMANDS)

### 6.1 TELECOMMANDS

MIRO is operated through telecommands. The telecommands are divided into six functional groups.

1. Warm Up Telecommands
2. Mode Change Telecommands
3. Additional Engineering Mode Telecommands
4. Additional Continuum Mode Telecommands
5. Additional Spectroscopic Mode Telecommands
6. Calibration Mirror Control Telecommands
7. Software Telecommands
8. Spacecraft Interface Telecommands

Each telecommand has parameters with a set of fixed values that can be assigned to them.

#### 6.1.1 WARM UP TELECOMMANDS

The warm up telecommands are used when MIRO is first powered up.

##### 6.1.1.1 Calibration Heater Telecommand

###### 6.1.1.1.1 Description

There are two calibration loads in the MIRO instrument, one internal to the Sensor Unit and one mounted externally under the primary mirror of the telescope. The MIRO instrument is radiometrically calibrated by correlating its measured response when looking at each of the calibration loads with their physical temperature. For this calibration to be accurate, the difference in the two loads' temperature should be greater than 30°C. The cold load will be at the temperature of the external environment. This is expected to become quite cold when the Rosetta spacecraft is far from the sun. The warm load is at the ambient temperature inside the spacecraft maintained between -20°C and +50°C. The purpose of the calibration heater is increase the temperature of the warm (load should the two loads be within 30°C of each other.

The calibration heater command, when turned on supplies current to a heater on the warm calibration load. With this current applied the warm load heats up about 30°C above its ambient temperature. When the calibration heater is turned off, the warm load temperature returns to ambient.

### 6.1.1.1.2 Packet Definition

Data Element	Size (bits)	Value (binary)	Comment
Version Number	3	000	EID-A Mandatory
Type	1	1	EID-A Mandatory
Data Field Header Flag	1	1	EID-A Mandatory
Application Process ID	7	1000111	EID-A Specified, 71
Packet Category	4	1100	EID-A Specified, Private (science) = 12
Sequence Flags	2	11	EID-A Mandatory
Sequence Count	14	000 + 1 up counter	First 3 bits are zero indicating 'Ground' as the source. The remaining 11 bits are zero initially, and constitute a one-up Telecommand counter. A separate counter is used for each APID/Packet Category combination.
Packet Length	16	0000000000000111	This gets set to the size of the application data field (in bytes) + 5. In this case, 7.
PUS Version	3	000	EID-A Specified, Ground Sourced Telecommand
Checksum Flag	1	1	EID-A Mandatory
Ack	4	0001	EID-A Specified, Acknowledgement of Acceptance
Packet Type	8	11000000	EID-A Specified, Private Telecommand = 192
Packet Subtype	8	01100101	EID-A Optional, 101 = Calibration Heater Power
Pad	8	00000000	EID-A Mandatory
Application Data	16	Variable	0-1 decimal: 0=Heater Off, 1=Heater On
Packet Error Control	16	Variable	Telecommand Packet Checksum

### 6.1.1.1.3 Parameters

The parameters are contained in the application data of the packet.

Calibration heater state: On (1), Off (0)

### 6.1.1.1.4 Execution Description

Upon receipt of this TC the inbound FIFO manager task immediately clocks the specified setting out to the hardware.

#### 6.1.1.1.4.1 Action Taken

Bit 14 of address 100 of the control register is set to the value specified.

#### 6.1.1.1.4.2 Resulting Effect

The resulting effect has three parts—(1) the software command is reflected in either Address Register 100 or the Sensor Unit Control Register (SUCR) control bits, (2) the change in temperature, voltage, etc., as measured by sensors, and (3) impact on the science data. The direct effect of this command is that the temperature of the warm load should increase. The two temperatures, measured by two sensors on the Warm load should increase. In addition the current and voltage change on the supply lines. Also as mentioned above Bit 14 of address

register 100 is set to 1. The typical effect on telemetry is summarized below. (Note that the actual voltages vary depending on the instrument state and may even go in the opposite direction. See expected values for telemetry in 6.2. However it should change.)

Calibration Heater Telecommand	Off	On
<b>Control Bits</b>		
AddReg 100, Bit 14 (NMRA0005, bit 9)	0	1
<b>Sensor Results</b>		
Warm Load 1 (NMRA0033)	ambient	ambient +30°C
Warm Load 2 (NMRA0044)	ambient	ambient +30°C
+24 V EU (NMRA0020)	23.1V	24.87
+24 V Current (NMRA0026)	0.02A	0.05A

The impact on the science data:

The measured continuum channels should increase. The measured spectroscopic calibration data should increase.

#### 6.1.1.1.4.3 *Additional Information*

During initial software startup following power on or during a software restart to incorporate memory patches this value is set to 0 (off).

#### 6.1.1.1.5 **RSDB Inputs**

Telecommand: ZMR19208 –Calibration Heater Power

Parameters: PMRG0014 –PLL Reset, default 0, Off  
CMRV0005

0, off

1, on

## 6.1.1.2 USO Power Telecommand

### 6.1.1.2.1 Description

The USO provides the frequency reference for spectroscopic measurements. It takes about 8 hours to stabilize. It is automatically turned on in the two spectroscopic modes. This commands allows it to be turned on in any mode so that it can warm up prior to initiating a spectroscopic mode.

### 6.1.1.2.2 Packet Definition

Data Element	Size (bits)	Value (binary)	Comment
Version Number	3	000	EID-A Mandatory
Type	1	1	EID-A Mandatory
Data Field Header Flag	1	1	EID-A Mandatory
Application Process ID	7	1000111	EID-A Specified, 71
Packet Category	4	1100	EID-A Specified, Private (science) = 12
Sequence Flags	2	11	EID-A Mandatory
Sequence Count	14	000 + 1 up counter	First 3 bits are zero indicating 'Ground' as the source. The remaining 11 bits are zero initially, and constitute a one-up Telecommand counter. A separate counter is used for each APID/Packet Category combination.
Packet Length	16	000000000000111	This gets set to the size of the application data field (in bytes) + 5. In this case, 7.
PUS Version	3	000	EID-A Specified, Ground Sourced Telecommand
Checksum Flag	1	1	EID-A Mandatory
Ack	4	0001	EID-A Specified, Acknowledgement of Acceptance
Packet Type	8	11000000	EID-A Specified, Private Telecommand = 192
Packet Subtype	8	00001011	EID-A Optional, 11 = USO Power
Pad	8	00000000	EID-A Mandatory
Application Data	16	Variable	0-1 decimal: 0=USO Off, 1=USO On
Packet Error Control	16	Variable	Telecommand Packet Checksum

### 6.1.1.2.3 Parameters

The parameters are contained in the application data of the packet.

USO state: On (1), Off (0)

### 6.1.1.2.4 Execution Description

Upon receipt of this TC the inbound FIFO manager task immediately clocks the specified setting out to the hardware.

#### 6.1.1.2.4.1 Action Taken

Bit 13 of address 100 of the control register is set to the value specified.

#### 6.1.1.2.4.2 *Resulting Effect*

The resulting effect has three parts—(1) the software command is reflected in either Address Register 100 or the Sensor Unit Control Register (SUCR) control bits, (2) the change in temperature, voltage, etc., as measured by sensors, and (3) impact on the science data. The direct effect of this is that the USO is turned on or off. The USO is temperature stabilized. It has two sensors—TLM Heating and TLM RF. The first is a measure of the temperature stabilizing circuit operation, the second is a measure of the output power. These two indicators are not calibrated. The supply voltage and current also change. The typical effect on telemetry is summarized below.

USO Power Telecommand	Off	On
<b>Control Bits</b>		
AddReg 100, Bit 13 (NMRA0005, bit 10)	0	1
<b>Sensor Results</b>		
TLM Heating (NMRA0027)	0.01	1.35
TLM RF (NMRA0028)	0.01	0.05
+24V (NMRA0020)	23.37	23.5
+24V Current (NMR0026)	0.02A	0.4A

Impact on the science data: The frequency calibration of the spectroscopic data will be correct. There is no way of verifying this from the data other than looking at a source with a know spectroscopic signature, such as an astrophysical source.

#### 6.1.1.2.4.3 *Additional Information*

During initial software startup following power on or during a software restart to incorporate memory patches this value is set to 0.

#### 6.1.1.2.5 **RSDB Inputs**

Telecommand: ZMR19209 –USO Power

Parameters: PMRG0015 –PLL Reset, default 0, Off

CMRV0005

0, off

1, on

### 6.1.1.3 CTS Warm Up Telecommand

#### 6.1.1.3.1 Description

The analog part (SAW filters) of the CTS is temperature controlled. For optimum performance of the thermal feedback analog part of the CTS should be at least 20C above ambient. This command turns on the thermal control. It takes about an hour for the CTS to stabilize.

In addition, the CTS does not turn on correctly if it is below about  $-5^{\circ}\text{C}$ . Therefore it needs to be warmed up prior to turning it on. It warms up in a few minutes after executing this command.

This command can be executed in any non-spectroscopic mode. In a spectroscopic mode the CTS heater command should be used to change the temperature for the thermal control.

#### 6.1.1.3.2 Packet Definition

Data Element	Size (bits)	Value (binary)	Comment
Version Number	3	000	EID-A Mandatory
Type	1	1	EID-A Mandatory
Data Field Header Flag	1	1	EID-A Mandatory
Application Process ID	7	1000111	EID-A Specified, 71
Packet Category	4	1100	EID-A Specified, Private (science) = 12
Sequence Flags	2	11	EID-A Mandatory
Sequence Count	14	000 + 1 up counter	First 3 bits are zero indicating 'Ground' as the source. The remaining 11 bits are zero initially, and constitute a one-up Telecommand counter. A separate counter is used for each APID/Packet Category combination.
Packet Length	16	0000000000000111	This gets set to the size of the application data field (in bytes) + 5. In this case, 7.
PUS Version	3	000	EID-A Specified, Ground Sourced Telecommand
Checksum Flag	1	1	EID-A Mandatory
Ack	4	0001	EID-A Specified, Acknowledgement of Acceptance
Packet Type	8	11000000	EID-A Specified, Private Telecommand = 192
Packet Subtype	8	00010011	EID-A Optional, 19 = CTS Warm up
Pad	8	00000000	EID-A Mandatory
Application Data	16	Variable	Detailed definition on following page
Packet Error Control	16	Variable	Telecommand Packet Checksum

## CTS Warm Up Telecommand Application Data Definition

Data Element	Size (bits)	Value (binary)	Comment
CTS Heater Power	4		0=High, 1=Off, 2=Low
CTS Heater Temperature	4		All values are degrees C; 0=0, 1=10, 2=20, 3=30, 4=40, 5=50, 6=60, 7=70
Reserved	8		Not Used

**6.1.1.3.3 Parameters**

The parameters are contained in the application data of the packet.

CTS Heater Temperature (PMRD2701): 0, 10, 20, 30, 40, 50, 60, 70

CTS Heater Power (PMRD2702): High, Off, Low

**6.1.1.3.4 Execution Description**

Upon receipt of this TC the inbound FIFO manager task sets a semaphore to tell the memory check task to perform the CTS warm up processing.

*6.1.1.3.4.1 Action Taken*

The memory check task powers on the CTS and sets the analog SAW filter temperature and power levels as specified in the TC. The CTS internal clocks are then turned off to reduce power consumption. The CTS digital electronics remain on. The global variable that contains the CTS temperature and power level is also set as specified by the TC.

*6.1.1.3.4.2 Resulting Effect*

The resulting effect has three parts—(1) the software command is reflected in either Address Register 100 or the Sensor Unit Control Register (SUCR) control bits, (2) the change in temperature, voltage, etc., as measured by sensors, and (3) impact on the science data. The direct effect of this is that the thermal control for the analog SAW filters of the CTS is turned on and set to the input temperature. The heating rate is determined by the power level. There are 6 temperature sensors in the CTS. Spect Temp 1–4 are in the analog part. Spect Temp 5–6 are in the digital part. The first four temperatures should stabilize at the commanded temperatures. The last 2 temperatures will increase by about 5–10°C. The supply voltage and current also change. The typical effect on telemetry is summarized below.

CTS Warm Up Telecommand	Off	On
<b>Control Bits</b>		
Add Reg 100, bit 9 (NMRA0005, bit 14)	0	1
Add Reg 100, bit 11 (NMRA0005, bit 12)	0	1
Add Reg 100, bit 10 (NMRA0005, bit 13)	0	1
Add Reg 100, bit 8 (NMRA0005, bit 15)	0	1
Add Reg 100, bit 12 (NMRA0005, bit 11)	0	1
Add Reg 100, bit 15 (NMRA0005, bit 8)	0	1
<b>Sensor Results</b>		
Spect Temp #1 (analog) (NMRA0009)	ambient	commanded temperature
Spect Temp #2 (analog) (NMRA0010)	ambient	commanded temperature
Spect Temp #3 (analog) (NMRA0011)	ambient	commanded temperature
Spect Temp #4 (analog) (NMRA 0012)	ambient	commanded temperature
Spect Temp #5 (digital) (NMRA0013)	ambient	ambient + 5°C
Spect Temp #6 (digital) (NMRA0014)	ambient	ambient + 5°C
+12V EU (NMRA0016)	13.20V	12.29V
+12V Curr EU (NMRA0022)	0.07A	0.31A

Impact on the science data: There is no easily measured impact on the science data. The CTS spectroscopic data will be more stable when the CTS SAW filters are maintained at a constant temperature.

#### 6.1.1.3.4.3 *Additional Information*

When the CTS is warming up great care must be taken to not perform a mode change to a mode where the CTS is not normally on because the CTS will then be powered off and the benefit of the warm up will be reduced.

The default setting of the global variable that contains the CTS temperature and power level is 30°C and low power. The default setting of the global variable takes place when either the instrument is powered on or a software restart TC is processed. The setting of the CTS heater temperature and power level in the CTS itself does not take place until the CTS is turned on. In the case where this TC is used to warm up the CTS and also to set the CTS temperature and power global variable, that setting will remain in memory even when the instrument is put into a mode where the CTS is powered off. Upon entering a mode where the CTS is again powered on the global variable will be used to set the CTS temperature and power level to the previous setting.

Once the CTS warm up command has been issued there is no way 'turn off' the warming up process other than performing a mode change to a mode where the CTS is not on. The 'CTS Heater Power' data element described above when set to off does not turn the CTS warm up off it sets the heater power to the analog SAW filter heaters off. The CTS digital electronics remain powered.

Thermal-Vacuum testing of the CTS has shown that at temperatures around -5°C and below the CTS electronics need to be warmed up for a period of a few



minutes to insure that the internal calibration of the CTS sum of squares table is performed correctly. Failing to warm up for a sufficient period of time, or simply switching to a CTS operational mode without warming up, could result in incorrectly calibrated CTS sum of squares tables. This will be evident in the CTS table midpoint values in the miscellaneous science TM packet. Nominal values for the CTS table midpoints fall within the range of 122–128. In the failure case the midpoints exceed 128 and are often in the area of 38000 and higher.

#### 6.1.1.3.5 RSDB Inputs

Telecommand: ZMR19221 – CTS Warm up

Parameters: PMRG0027 – CTS Warm up

PMRD2701 – CTS Heater Temperature

CMRV0016

0, 0 deg

1, 10 deg

2, 20 deg

3, 30 deg

4, 40 deg

5, 50 deg

6, 60 deg

7, 70 deg

PMRD2702 – CTS Heater Power

CMRV0017

0, High Power

1, Off

2, Low Power

PMRD2703 – Not Used

## 6.1.2 MODE CHANGE TELECOMMANDS

### 6.1.2.1 Mode Change Telecommand

#### 6.1.2.1.1 Description

MIRO has six primary modes:

1. Engineering mode
2. Millimeter-wave continuum mode
3. Submillimeter-wave continuum mode
4. Dual continuum mode
5. CTS/submillimeter-wave continuum mode
6. CTS/dual continuum mode

The Engineering mode is the lowest power mode. The flight computer is turned on and returns the engineering telemetry.

The continuum modes include the millimeter-wave continuum mode, the submillimeter-wave continuum mode and the dual continuum mode. In the millimeter-wave continuum mode only the millimeter-wave receiver is on and returning data. Similarly, in the submillimeter-wave continuum mode only the submillimeter-wave continuum receiver is on and returning data. In the dual continuum mode both the submillimeter-wave and millimeter-wave continuum receivers are on and returning data.

The spectroscopic modes include the CTS/submillimeter-wave continuum mode and the CTS/dual continuum mode. The submillimeter-wave receiver can return both continuum and spectroscopic data. To return spectroscopic data requires that the USO be on, the submillimeter-wave local oscillator be phase locked, and the intermediate frequency processor be operational, as well as the continuum parts of the receiver be on. The CTS/submillimeter-wave continuum mode returns both submillimeter-wave spectroscopic and continuum data. The CTS/dual continuum mode returns submillimeter-wave spectroscopic data, submillimeter-wave continuum data, and millimeter-wave continuum data.

The sequence followed for the continuum modes starts with a calibration that consists of (1) observing the “hot” load for 30 seconds, (2) observing the “cold” load for 30 seconds, (3) observing the “source” for 30 seconds, and (4) continuing to observe “source” position. This sequence is repeated every 33 minutes and 50 seconds. The data is returned as counts.

The sequence followed for the spectroscopic modes starts with (1) observing the “hot” load for 30 seconds with the frequency switching between LO 0 and LO 1 every 5 sec, (2) observing the “hot” load for 30 seconds with the frequency switching between LO 0 and LO 1 every 5 seconds, (3) observing the “source” position for 30 seconds with the frequency switching between LO 0 and LO 1 every 5 seconds, and (4) repeated “source” position observations for the

integration time with the frequency switching between LO 0 and LO 1 every 5 seconds. LO 1 shifts frequencies—5MHz (lower frequency). LO 0 shifts frequency +5MHz (higher frequency). This continues for 33 minutes and 50 seconds, when the sequence starts over. The calibration data is returned as 15 seconds of added data binned into LO 0 and LO 1 data sets, while the signal data is returned as LO 0–LO 1 data co-added for the integration time.

In addition to changing the mode, the parameters that control data volume associated with each mode are passed by this telecommand. Additional settings associated with each mode have separate telecommands given later.

### 6.1.2.1.2 Packet Definition

Data Element	Size (bits)	Value (binary)	Comment
Version Number	3	000	EID-A Mandatory
Type	1	1	EID-A Mandatory
Data Field Header Flag	1	1	EID-A Mandatory
Application Process ID	7	1000111	EID-A Specified, 71
Packet Category	4	1100	EID-A Specified, Private (science) = 12
Sequence Flags	2	11	EID-A Mandatory
Sequence Count	14	000 + 1 up counter	First 3 bits are zero indicating 'Ground' as the source. The remaining 11 bits are zero initially, and constitute a one-up Telecommand counter. A separate counter is used for each APID/Packet Category combination.
Packet Length	16	0000000000000111	This gets set to the size of the application data field (in bytes) + 5. In this case, 7.
PUS Version	3	000	EID-A Specified, Ground Sourced Telecommand
Checksum Flag	1	1	EID-A Mandatory
Ack	4	0001	EID-A Specified, Acknowledgement of Acceptance
Packet Type	8	11000000	EID-A Specified, Private Telecommand = 192
Packet Subtype	8	00000101	EID-A Optional, 5 = Mode Change
Pad	8	00000000	EID-A Mandatory
Application Data	16	Variable	Detailed definition on following page
Packet Error Control	16	Variable	Telecommand Packet Checksum

### Mode Change Telecommand Application Data Definition

Data Element	Size (bits)	Value (binary)	Comment
Power mode	3		1=CTS/Dual Continuum, 2=CTS/SMM Continuum, 3=Dual Continuum, 4=SMM Continuum, 5=MM Continuum, 6=Engineering
CTS integration period	2		0=30 sec, 1=60 sec, 2=90 sec, 3=120 sec
Continuum summing value	3		0=sum 1, 1=sum 2, 2=sum 5, 3=sum 10, 4=sum 20
CTS smoothing value	2		0=smooth 1, 1=smooth 2, 2=smooth 3, 3=smooth 4
Reserved	1		Not used
Reserved	1		Not used
Reserved	4		Not Used

### 6.1.2.1.3 Parameters

The parameters are contained in the application data of the packet.

Power mode: selects one of six power modes. The instrument is in engineering mode when powered on.

CTS integration period: selects one of four integration periods for the submillimeter-wave spectroscopic data. 30 seconds is the default. This parameter is set greater than the default in order to reduce data volume for a given period of time. When this parameter is set to 120 seconds, for instance, four 30-second data sets are averaged together on-board. This does not affect the continuum data.

Continuum summing value: This selects the number of continuum data sets to add together on-board. The default is to sum 1 data set. This parameter is set greater than the default in order to reduce data volume for a given period of time. When this parameter is set to sum 10, for instance, 10 continuum values are added together on board. Note that the data is summed, not averaged. This is applied to the millimeter-wave and/or submillimeter-wave continuum data. This does not effect the spectroscopic data.

CTS smoothing value: This parameter smoothes the spectroscopic data in frequency. The default value is "smooth 1" which returns all 4096 of the CTS channels. This parameter is set greater than the default in order to reduce data volume for a given period of time. "Smooth 2", for instance, reduces the number of CTS channels by a factor of 2, from 4096 to 2048.

### 6.1.2.1.4 Execution Description

The inbound FIFO manager task parses the information contained in the mode change TC and stores it in global memory for use by the executive task. The inbound FIFO manager task then sets the mode\_change semaphore to notify the executive task that a mode change has been commanded.

The executive task checks for a mode change once per second while in the nominal processing loop.

#### 6.1.2.1.4.1 Action Taken

Upon detection of a mode change command the executive task begins a graceful shutdown of the software in the current mode of operation. If running in a mode where the CTS is operating the current CTS integration is allowed to complete. If we are running in one of the continuum modes the current 5 seconds (100 samples) of continuum data collection is allowed to complete. In both of these cases all collected science TM data is processed and flushed out to the outbound FIFO manager task as part of the graceful shutdown.

Following the graceful shutdown the executive task sets all required global variables to control the transition to the new operating mode. Any required powering off/on of the various hardware components is then performed. The

software then enters the new operating mode and an instrument calibration is performed provided the new mode is anything other than engineering mode. If the CTS has been powered on as part of the new mode then the instrument calibration is preceded by an internal CTS calibration.

#### 6.1.2.1.4.2 Resulting Effect

The resulting effect has three parts—(1) the software command is reflected in either Address Register 100 or the Sensor Unit Control Register (SUCR) control bits, (2) the change in temperature, voltage, etc., as measured by sensors, and (3) impact on the science data.

The software will enter the new operating mode following a graceful shutdown of the previous mode. New telemetry output rates and power consumption will be in effect depending on the operational mode that is entered.

The typical effect on address register 100 and SUCR is summarized below. Values for temperatures, voltages and currents can be found in Section 6.2.2.3 Expected Values for engineering telemetry.

Function	Telemetry	Eng.	mm cont	smm cont.	Dual cont	CTS/SMM	CTS/Dual
Operational Mode (Power Mode)	NMRA0002 (NMRD0201)	6	5	4	3	2	1
Operational Mode (CTS Integration Period)	NMRA0002 (NMRD0202)	NA	NA	NA	NA	0=30s, 1=60s, 2=90s, 3=120s	0=30s, 1=60s, 2=90s, 3=120s
Operational Mode (Continuum Sum Value)	NMRA0002 (NMRD0203)	NA	0=sum 1 1=sum 2 2=sum 5 3=sum10 4=sum20	0=sum 1 1=sum 2 2=sum 5 3=sum10 4=sum20	0=sum 1 1=sum 2 2=sum 5 3=sum10 4=sum20	0=sum 1 1=sum 2 2=sum 5 3=sum10 4=sum20	0=sum 1 1=sum 2 2=sum 5 3=sum10 4=sum20
Operational Mode (CTS Smoothing Value)	NMRA0002 (NMRD0204)	NA				0=sm 1 1=sm 2 2=sm 3 3=sm 4	0=sm 1 1=sm 2 2=sm 3 3=sm 4
-5V SBEU for mm cont.	SUCR bit 25 (NMRA0004, bit 6)	0	1	0	1	0	1
-5V SBEU for smm cont	SUCR bit 24 (NMRA0004, bit 7)	0	0	1	1	1	1
-5V SBEU for spectroscopy	SUCR bit 26 (NMRA0004, bit 5)	0	0	0	0	1	1
+5V SBEU, +/- 12V SBEU for mm cont.	SUCR bit 10 (NMRA0003, bit 5)	0	1	0	1	0	1

Function	Telemetry	Eng.	mm cont	smm cont.	Dual cont	CTS/SMM	CTS/Dual
+5V SBEU, +/- 12V SU for smm cont.	SUCR bit 5 (NMRA0003, bit 10)	0	0	1	1	1	1
+5V SBEU, +/- 12V SBEU for spect.	SUCR bit 11 (NMRA0003, bit 4)	0	0	0	0	1	1
+12V SPEC EU	Add Reg 100, bit 8 (NMRA0005, bit 15)	0	0	0	0	1	1
+5V Spec EU	Add Reg 100, bit 9 (NMRA0005, bit 14)	0	0	0	0	1	1
+5V ANA SPEC EU	Add Reg 100, bit 10 (NMRA0005, bit 13)	0	0	0	0	1	1
+3.V SPEC EU	Add Reg 100, bit 11 (NMRA0005, bit 12)	0	0	0	0	1	1
-12V SPEC EU	Add Reg 100, bit 12 (NMRA0005, bit 11)	0	0	0	0	1	1

The result on the science data: Typical science data are given in Section 6.2 as follows:

Section 6.2.3 Spectroscopic (CTS) Science Telemetry (YMR00011)

Section 6.2.4 Submillimeter Continuum Science Telemetry (YMR00011)

Section 6.2.5 Millimeter Continuum Science Telemetry (YMR00011)

Section 6.2.6 Miscellaneous Science Telemetry (YMR00011)

For the spectroscopic modes the CTS sum-of-squares table midpoints will be placed in the miscellaneous science file. This is one of the earliest diagnostics to determine if the CTS is operating correctly. The CTS warm up telecommand should be executed prior to the change mode command if its operating temperature is below about -5C. If the CTS is operating correctly, the midpoints of the sum-of-squares tables will all be about 125. If is not, then one or more midpoints is zero.

The frequency smoothing is accomplished as described below.

Smoothing Shift = 1: All 4096 values are returned.

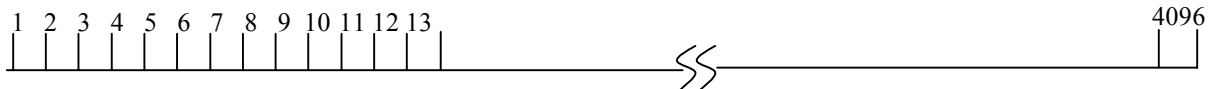

Smoothing Shift = 2: Window size of 5 is shifted over data set 2 positions at a time. Returned value is computed as a mathematical weighting function of the 5 values in the window. The smoothing weights are 0.03, 0.22, 0.50, 0.22, 0.03, respectively. 2046 values are returned.

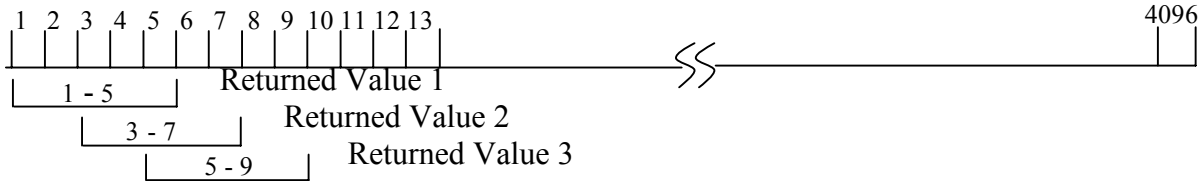

Smoothing Shift = 3: Window size of 7 is shifted over the data set 3 positions at a time. Returned value is computed as a mathematical weighting function of the 7 values in the window. The smoothing weights are 0.01, 0.03, 0.30, 0.32, 0.30, 0.03, 0.01, respectively. 1364 values are returned.

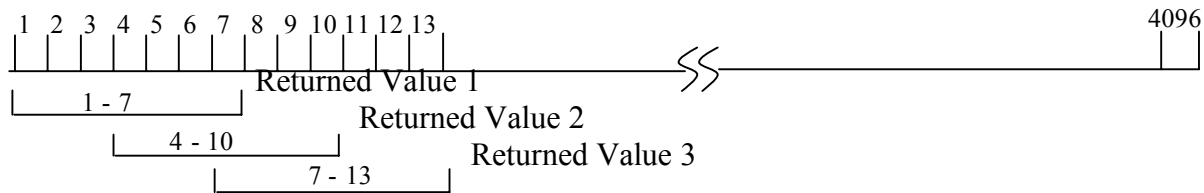

Smoothing Shift = 4: Window size of 9 is shifted over the data set 4 positions at a time. Returned value is computed as a mathematical weighting function of the 9 values in the window. The smoothing weights are 0.01, 0.03, 0.11, 0.23, 0.24, 0.23, 0.11, 0.03, 0.01, respectively. 1022 values are returned.

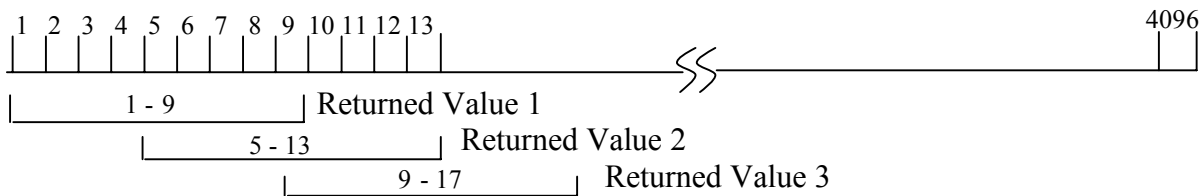

**6.1.2.1.4.3 Additional Information**

The executive assembly only processes mode change commands during the nominal processing loop. This means that any mode changes sent to the software during instrument calibration will not be acted upon until after the instrument calibration is complete. For example, if the instrument is running in engineering mode and is then commanded into CTS / dual continuum mode the following will take place. The numerous hardware components will be powered on, the CTS internal sum of squares table will be initialised, and an instrument calibration will be performed. This requires approximately 2.5 minutes. During that 2.5 minutes, the executive assembly is not checking for any further mode change commands. The first CTS integration is started, and then the executive assembly enters the nominal processing loop where mode change commands are processed. Any

mode change sent in during the prior 2.5 minutes will then be acted upon. Assuming a mode change was sent to the instrument during that time, a graceful shutdown will allow for at a minimum of 1 CTS integration period to complete, which could require anywhere from an additional 30–120 seconds depending on the CTS integration period. In the case where multiple mode change commands are sent to the instrument during the instrument calibration, only the last one received is processed. Mode change commands are not kept in a buffer, only the last one received is processed.

#### 6.1.2.1.5 RSDB Inputs

Telecommand: ZMR19214 – Mode Change

Parameters: PMRG0020 – Defines Operating Mode

PMRD2001 – Power Mode, default = Engineering

CMRV0012

- 1, CTS/Dual Cntm
- 2, CTS/SMMCntm
- 3, DualContinm
- 4, SMMContinuum
- 5, MM Continuum
- 6, Engineering

PMRD2002 – CTS Integration Period, default = 30 s

CMRV0013

- 0, 30 sec
- 1, 60 sec
- 2, 90 sec
- 3, 120 sec

PMRD2003 – Continuum Sum Value, default = Sum 1

CMRV0014

- 0, Sum 1
- 1, Sum 2
- 2, Sum 5
- 3, Sum 10
- 4, Sum 20

PMRD2004 – CTS Smoothing Value, default =Smooth 1

CMRV0015

- 0, Smooth 1
- 1, Smooth 2
- 2, Smooth 3
- 3, Smooth 4

PMRD2005 – Reserved

PMRD2006 – Reserved

PMRD2007 - Reserved



## 6.1.2.2 Asteroid Mode Telecommand

### 6.1.2.2.1 Description

The asteroid mode telecommand is a complex command calling the other modes in a timed sequence. Asteroid Mode returns “raw” data, the only mode that does so.

#### *Time line for asteroid mode*

All times will be referenced to the Start Time in the Asteroid Mode command, which is when data in asteroid mode start to be generated. The time when the spacecraft is at closest approach to the asteroid is called the “asteroid flyby time”. Prior to this time the spacecraft is approaching the asteroid, after it the spacecraft is leaving the asteroid. At the asteroid flyby time the relative velocity between the spacecraft and the asteroid is zero.

Time	Name	Type	Event
-2 hour (at least)		manual	MIRO instrument turned on and warmed up (USO on, Cal Heater on, CTS warm up 70C/High)
-7 min (at least)		manual	Execute Asteroid mode command
-(4 min + CTS integration time) (at least)		manual	Execute Change Mode to Dual Continuum Mode
-119 sec		Carried out automatically by asteroid command	<ol style="list-style-type: none"> <li>1. graceful shutdown,</li> <li>2. power up for asteroid mode,</li> <li>3. CTS internal calibration,</li> <li>4. SMM Gunn voltage auto scan</li> </ol>
0	Start time	Carried out automatically by asteroid command	Start calibration
133.5 sec		Carried out automatically by asteroid command	Start taking N data sets with LO frequency in starting “LO frequency setting”
133.5+N*5.26 sec [10.7 minutes max]	Asteroid flyby time	Carried out automatically by asteroid command	LO setting switched, take N data sets
133.5+N*10.52 sec [19 minutes max]		Carried out automatically by asteroid command	Start calibration
267+N*10.52 sec [21.3 minutes max]		Carried out automatically by asteroid command	change mode to Dual continuum mode
387+N*10.52 sec		manual	change mode to CTS/Dual Continuum to maximize data playback rate (NOTE: if data taken in this mode are of value, precede this with a CTS warm up command!)
67+1.8*N minutes (approx.)	Playback end	manual	All asteroid data read out. Execute change mode to Engineering

The maximum time for this whole procedure to take place, starting two hours prior to the start time, is about 6 hrs in the longest case. It is a function of the Execution time parameter, N, as follows:

Time to complete=3.1+0.03\*N (hours).

At at [please clarify] point, all the data taken in asteroid mode will have been played out. However, the data taken in CTS/Dual mode during the playback period will only be beginning to be played out. The choice must then be made whether to switch the instrument off and lose these latter data or wait until the playback has “caught up”, which will take many more hours.

### ***LO Setting***

The LO setting is optimized for the H<sub>2</sub>O line. The frequency of the water line (and all the other lines) is Doppler shifted due to the relative motion of the spacecraft and the source of emission (the asteroid). It moves from high frequency (approaching the asteroid) to low frequency (departing from the asteroid). However the direction that this frequency shifts in the MIRO spectrometer depends on which sideband the line is in for each of its downconversions. This varies with each line as shown in the table below.

Line	Initial LO Setting	Frequency Shift in Spectrometer on Approach	Frequency Shift in Spectrometer on Departure	Spectrometer Frequency with no Shift (MHz)
H216O	1	-	+	1270
H217O	1	-	+	1300
CH3OH	0	+	-	1320
H218O	1	-	+	1340
CO	1	-	+	1363
CH3OH	1	-	+	1389
NH3	0	+	-	1407
CH3OH	1	-	+	1425

LO 1 shifts frequencies – 5MHz (lower frequency). LO 0 shifts frequency +5MHz (higher frequency).

## 6.1.2.2.2 Packet Definition

Data Element	Size (bits)	Value (binary)	Comment
Version Number	3	000	EID-A Mandatory
Type	1	1	EID-A Mandatory
Data Field Header Flag	1	1	EID-A Mandatory
Application Process ID	7	1000111	EID-A Specified, 71
Packet Category	4	1100	EID-A Specified, Private (science) = 12
Sequence Flags	2	11	EID-A Mandatory
Sequence Count	14	000 + 1 up counter	First 3 bits are zero indicating 'Ground' as the source. The remaining 11 bits are zero initially, and constitute a one-up Telecommand counter. A separate counter is used for each APID/Packet Category combination.
Packet Length	16	0000000000001101	This gets set to the size of the application data field (in bytes) + 5. In this case, 13.
PUS Version	3	000	EID-A Specified, Ground Sourced Telecommand
Checksum Flag	1	1	EID-A Mandatory
Ack	4	0001	EID-A Specified, Acknowledgement of Acceptance
Packet Type	8	11000000	EID-A Specified, Private Telecommand = 192
Packet Subtype	8	00001111	EID-A Optional, 15 = Asteroid mode
Pad	8	00000000	EID-A Mandatory
Application Data	64	Variable	Detailed definition on following page
Packet Error Control	16	Variable	Telecommand Packet Checksum

### Asteroid Mode Telecommand Application Data Definition

Data Element	Size (bits)	Value (binary)	Comment
Start Time	32	Variable	Spacecraft time in seconds
Execution Time	16	Variable	Number of 5-second CTS scans per LO frequency. Must be an even number between 2 and 96.
Starting LO frequency	16	0 or 1	LO frequency to start on, switch to other as per science FR document

## 6.1.2.2.3 Parameters

The parameters are contained in the application data of the packet.

Start time (PMRG2501 Astrd Mode #1) (=asteroid flyby time – (N\*5.3+139)[sec])

Start Time is the time at which the asteroid mode begins its automated sequence. This should precede the Asteroid Flyby time by an interval equal to the Execution

Time parameter multiplied by 5.3 seconds plus the time for a calibration (139 secs). Start Time must be at least 15 minutes later than the time at which the Asteroid Mode command is issued. The units of Start Time are spacecraft time in seconds.

Execution time (PMRD2502) (N, =even number between 2 and 96)

Execution Time is the number of 5-second CTS scans per LO frequency that are done before and after the encounter. This value must be an even integer between 2 and 96.

Starting LO Frequency (PMRD2503) (=0 or 1)

For CTS warm up command

CTS Heater Temperature (PMRD2701) (= 0, 10, ..., 50, 60, 70 deg)

CTS Heater Power (PMRD2703) (=High or Low)

For Dual continuum time (=Execution time (PMRD2502)\*.37 hours)

Dual Continuum Observation Time is the time to read out the data taken during the asteroid encounter. Data continues to be taken in Dual Continuum mode, after the asteroid mode sequence has been completed.

#### 6.1.2.2.4 Execution Description

Upon receipt of this TC the inbound FIFO manager task checks to verify that the start time of the asteroid mode is at a minimum of 130 seconds in the future. If that is the case then a global variable is set to notify the executive task that asteroid mode has been programmed. (Note that 130 seconds is an absolute lower limit; in practice the interval should be considerably longer, see Timeline, above.)

##### 6.1.2.2.4.1 Action Taken

Once notified that asteroid mode is programmed the executive task begins checking once per second if it is time to begin asteroid mode processing by performing a graceful software shutdown of the current operational mode. Once the graceful shutdown has been completed the powering up for asteroid mode is done. An internal CTS table calibration is performed and the SMM Gunn Voltage setting is found using the nominal search described earlier. The asteroid mode routine is called by the executive task and all high level control over asteroid mode processing is done there.

##### 6.1.2.2.4.2 Resulting Effect

The programmed asteroid mode sequence is executed at the time specified in the asteroid mode command.

The asteroid mode doesn't do anything until about 2 minutes prior to the start time except check to see if it is time to start its automated sequence. At about 2

minutes prior to the start time the instrument should be in dual continuum mode and fully warmed up.

The effect of the asteroid mode command will be to place MIRO in CTS / Dual Continuum mode about 2 minutes prior to the Start Time, calibrate the instrument, take a number (N) of CTS scans with the LO set at its initial frequency, change to the other LO setting and take another N scans, calibrate again and then to return automatically to Dual Continuum mode.

To verify that the asteroid mode has been activated check the asteroid mode programmed and asteroid mode start time parameters in the Miscellaneous file.

In addition, progress event reports are generated.

- *Asteroid Mode Started (YMR00013)* is generated when the flight software begins running the asteroid mode sequence. This should correlate to the asteroid mode start time issued in the asteroid mode TC.
- *Asteroid Mode Completed (YMR00014)* is generated when the flight software completes the asteroid mode sequence.

#### 6.1.2.2.4.3 *Additional Information*

Running in asteroid mode generates a large amount of CTS data that are internally buffered in the instrument. These data are played back in the mode selected following asteroid mode, during which time the instrument will be taking more data in that mode. It can take as long as 35 hours for the playback to catch up to the data being acquired. If the instrument is powered down, or a software restart is performed, or disable science telemetry command is executed for any reason all accumulated data that is buffered internally will be lost.

The instrument can be in any mode when the command is sent to program asteroid mode. However, to transition to asteroid mode correctly the instrument must be in dual continuum mode at the time that the graceful shutdown is performed prior to starting asteroid mode. This time is approximately 120 seconds prior to the programmed asteroid mode start time.

During initial software startup following power on or during a software restart to incorporate memory patches there is no asteroid mode programmed by default.

#### 6.1.2.2.5 **RSDB Inputs**

Telecommand: ZMR19219 – Asteroid Mode

Parameters: PMRG2501 – Astrd Mode#1 (Start Time)  
PMRG2502 – Astrd Mode#2  
PMRD2502 – Execution Time  
PMRD2503 – Starting LO Frequency  
CMRV0019

0, LO Freq 0

1, LO Freq 1

## 6.1.3 ADDITIONAL ENGINEERING MODE TELECOMMANDS

### 6.1.3.1 Engineering Housekeeping Cycle Skip Telecommand

#### 6.1.3.1.1 Description

The digital noise generated when reading the engineering housekeeping data every 11 seconds can cause excess noise in the continuum data. The engineering housekeeping cycle skip command can be used to skip this readout for a certain period of time in order to eliminate this noise source.

#### 6.1.3.1.2 Packet Definition

Data Element	Size (bits)	Value (binary)	Comment
Version Number	3	000	EID-A Mandatory
Type	1	1	EID-A Mandatory
Data Field Header Flag	1	1	EID-A Mandatory
Application Process ID	7	1000111	EID-A Specified, 71
Packet Category	4	1100	EID-A Specified, Private (science) = 12
Sequence Flags	2	11	EID-A Mandatory
Sequence Count	14	000 + 1 up counter	First 3 bits are zero indicating 'Ground' as the source. The remaining 11 bits are zero initially, and constitute a one-up Telecommand counter. A separate counter is used for each APID/Packet Category combination.
Packet Length	16	0000000000000111	This gets set to the size of the application data field (in bytes) + 5. In this case, 7.
PUS Version	3	000	EID-A Specified, Ground Sourced Telecommand
Checksum Flag	1	1	EID-A Mandatory
Ack	4	0001	EID-A Specified, Acknowledgement of Acceptance
Packet Type	8	11000000	EID-A Specified, Private Telecommand = 192
Packet Subtype	8	00010110	EID-A Optional, 22 = Engineering HK Cycle Skip
Pad	8	00000000	EID-A Mandatory
Application Data	16	Variable	Number of 11.2 second engineering cycles to skip data collection. Range of 0-65535.
Packet Error Control	16	Variable	Telecommand Packet Checksum

#### 6.1.3.1.3 Parameters

The parameters are contained in the application data of the packet.

N= number of 11.2 sec engineering data packets to skip reading. N=0 is the default.

#### 6.1.3.1.4 Execution Description

Upon receipt of this TC the inbound FIFO manager task immediately sets the global variable used to control the processing of the engineering data collection task.

##### 6.1.3.1.4.1 Action Taken

The engineering data collection task uses the global variable to determine how many 11.2-second engineering data collection cycles should be skipped following each cycle in which data is collected.

##### 6.1.3.1.4.2 Resulting Effect

The resulting effect has three parts—(1) the software command is reflected in either Address Register 100 or the Sensor Unit Control Register (SUCR) control bits, (2) the change in temperature, voltage, etc., as measured by sensors, and (3) impact on the science data.

In the telemetry: NMRAH143 MR71/4 DataFieldHdr time – successive values differ by  $(N+1)*11.2$  seconds.

The impact on the science: When set to a value other than 0, the engineering data collection task will not perform any A/D conversions of engineering data during the specified number of 11.2-second engineering collection cycles. No engineering HK packets will be generated during those cycles as a result. The continuum data, if we are running in a mode where it is being collected, will be more stable during the cycles of non-collection as opposed to when sensor unit A/D conversions are taking place.

##### 6.1.2.1.4.3 Additional Information

This TC was added solely for the purpose of allowing the ground controllers the option to ‘turn off’ engineering data collection for specific periods of time to collect cleaner continuum data. The TC to turn off engineering HK packet generation would not produce the same result, as that TC simply causes the software to drop collected packets on the floor, while the A/D conversions that cause the noise in the continuum channels continue. Upon initial power-on or a software restart the default setting for this value is zero, indicating that no collection cycles will be skipped. This is the nominal mode where engineering HK TM packets get generated every 11.2 seconds. Any changes made to the skip value will not be reflected until the following 11.2-second collection cycle. For example, if sometime after instrument power-on the TC was sent with a skip value of 10, the current 11.2-second cycle of collection would be completed prior to the engineering task then skipping the subsequent 10 collection cycles. While in the process of skipping the 10 cycles it is possible to increase the number of cycles to skip by sending another TC with a value greater than 10. If a TC were then sent to skip 20 cycles while the software was halfway through skipping 10

cycles the total number of cycles ultimately skipped would be exactly 20. There is no cumulative/additive effect. When the software finishes skipping the desired number of cycles it repeats the entire sequence again by collecting engineering data for 1 cycle and then skipping the desired number of cycles. This repeats indefinitely, until the cycle skip count is again changed by TC.

Lowering the skip count value from a higher value has 2 possible outcomes. If the new skip count value is *higher* than the number of cycles that have already been skipped then the software will simply keep skipping cycles until the new lower number of cycles has been skipped. If the new skip count value is *lower* than the number of cycles that have already been skipped then the next cycle that starts will be a good collection cycle followed by the new number of skipped cycles.

For purposes of simply ‘turning off’ engineering data collection for an indefinite period the best method would be to uplink this TC with a value of 65535. This will produce a skip period of 8.5 days, effectively turning off engineering data collection. When one wants to resume periodic engineering HK data collection just send the TC in with a more reasonable skip count value (i.e., 5) or just a zero to cause it to collect engineering HK data continuously.

#### **6.1.3.1.5 RSDB Inputs**

Telecommand: ZMR19224 – Engineering Housekeeping Cycle Skip

Parameters: PMRG0030 –Eng HK Cycles Skip



## 6.1.4 ADDITIONAL CONTINUUM MODE TELECOMMANDS

### 6.1.4.1 Continuum Subtraction Value Telecommand

#### 6.1.4.1.1 Description

The maximum value for continuum data, 32000, may be exceeding when looking at a very bright source or using the continuum summing capability in the mode change telecommand. When this happens, data is lost. Typical values for unsummed continuum data are about 7000. The continuum subtraction value telecommand allows the subtraction of an offset prior to summing to mitigate this problem. Different values can be entered for the millimeter-wave and submillimeter-wave continuum channels.

#### 6.1.4.1.2 Packet Definition

Data Element	Size (bits)	Value (binary)	Comment
Version Number	3	000	EID-A Mandatory
Type	1	1	EID-A Mandatory
Data Field Header Flag	1	1	EID-A Mandatory
Application Process ID	7	1000111	EID-A Specified, 71
Packet Category	4	1100	EID-A Specified, Private (science) = 12
Sequence Flags	2	11	EID-A Mandatory
Sequence Count	14	000 + 1 up counter	First 3 bits are zero indicating 'Ground' as the source. The remaining 11 bits are zero initially, and constitute a one-up Telecommand counter. A separate counter is used for each APID/Packet Category combination.
Packet Length	16	0000000000001001	This gets set to the size of the application data field (in bytes) + 5. In this case, 9.
PUS Version	3	000	EID-A Specified, Ground Sourced Telecommand
Checksum Flag	1	1	EID-A Mandatory
Ack	4	0001	EID-A Specified, Acknowledgement of Acceptance
Packet Type	8	11000000	EID-A Specified, Private Telecommand = 192
Packet Subtype	8	00001110	EID-A Optional, 14 = Continuum subtraction
Pad	8	00000000	EID-A Mandatory
Application Data	32	Variable	Detailed definition on following page
Packet Error Control	16	Variable	Telecommand Packet Checksum

#### Continuum Subtraction Telecommand Application Data Definition

Data Element	Size (bits)	Value (binary)	Comment
Millimeter Subtraction Value	16	Variable	Unsigned integer to be subtracted from each millimeter sample.
Sub-Millimeter Subtraction Value	16	Variable	Unsigned integer to be subtracted from each sub-millimeter sample.

### 6.1.4.1.3 Parameters

The parameters are in the application data.

- Millimeter-wave subtraction value: integer to be subtracted from the millimeter-wave continuum data.
- Submillimeter-wave subtraction values: integer to be subtracted from the submillimeter-wave continuum data.

### 6.1.4.1.4 Execution Description

Upon receipt of this TC the inbound FIFO manager task sets a global variable that is used by the continuum interrupt processing task.

#### 6.1.4.1.4.1 *Action Taken*

The continuum interrupt processing task uses the two subtraction values supplied to decrement the raw continuum samples taken every 50 milliseconds.

#### 6.1.4.1.4.2 *Resulting Effect*

The resulting effect has three parts—(1) the software command is reflected in either Address Register 100 or the Sensor Unit Control Register (SUCR) control bits, (2) the change in temperature, voltage, etc., as measured by sensors, and (3) impact on the science data.

No effect on the command address registers or the engineering sensors.

The impact on the science data:

1. The value of the millimeter-wave and submillimeter-wave continuum subtraction values are stored in the header of the continuum data files as well as in the Miscellaneous Science File.
2. The summed continuum samples that get output in the TM packets will be reduced.

#### 6.1.4.1.4.3 *Additional Information*

The continuum subtraction takes place prior to any other processing of the continuum data. Raw continuum samples are collected every 50 milliseconds and the continuum subtraction value is decremented from the raw samples. Only after this decrementing is the summing of the continuum samples performed as per the current continuum summing value specified in the operational mode. The continuum subtraction value is placed in the continuum TM packet to allow for easier decoding of the data. The continuum subtraction value is placed in the TM packet at the time of packet creation and will not reflect the continuum subtraction value later on in the TM packet if the subtraction value is changed during the course of populating the continuum TM packet. A continuum packet can take anywhere from 10 to 200 seconds to fill depending on the continuum summing value in effect. During initial software startup following power on or

during a software restart to incorporate memory patches the continuum subtraction values are set to zero.

#### **6.1.4.1.5 RSDB Inputs**

Telecommand: ZMR19218 Continuum Subtraction Value

Parameters: PMRG0024 – Continuum Subtr Values

PMRD2401 – MM Subtraction Value, default =0

PMRD2402 – SMM Subtraction Value, default=0

## 6.1.4.2 Millimeter LNA Power Telecommand

### 6.1.4.2.1 Description

This command turns the power on or off to the millimeter-wave receiver low noise amplifier on the optical bench. The power is turned off in order to obtain a “zero” value for the millimeter-wave continuum data calibration. This should be done at least once per millimeter-wave continuum, dual continuum, or CTS/dual mode observing session.

### 6.1.4.2.2 Packet Definition

Data Element	Size (bits)	Value (binary)	Comment
Version Number	3	000	EID-A Mandatory
Type	1	1	EID-A Mandatory
Data Field Header Flag	1	1	EID-A Mandatory
Application Process ID	7	1000111	EID-A Specified, 71
Packet Category	4	1100	EID-A Specified, Private (science) = 12
Sequence Flags	2	11	EID-A Mandatory
Sequence Count	14	000 + 1 up counter	First 3 bits are zero indicating 'Ground' as the source. The remaining 11 bits are zero initially, and constitute a one-up Telecommand counter. A separate counter is used for each APID/Packet Category combination.
Packet Length	16	000000000000111	This gets set to the size of the application data field (in bytes) + 5. In this case, 7.
PUS Version	3	000	EID-A Specified, Ground Sourced Telecommand
Checksum Flag	1	1	EID-A Mandatory
Ack	4	0001	EID-A Specified, Acknowledgement of Acceptance
Packet Type	8	11000000	EID-A Specified, Private Telecommand = 192
Packet Subtype	8	00000111	EID-A Optional, 7 = MM LNA Power
Pad	8	00000000	EID-A Mandatory
Application Data	16	Variable	0-1 decimal: 0=Power Off, 1=Power On
Packet Error Control	16	Variable	Telecommand Packet Checksum

### 6.1.4.2.3 Parameters

The parameters are given in the packet application data.

mm LNA power state (PMRG0009) : Power off=0, Power on = 1

### 6.1.4.2.4 Execution Description

Upon receipt of this TC the inbound FIFO manager task immediately clocks the specified setting out to the hardware.

#### 6.1.4.2.4.1 *Action Taken*

Bit 8 of address 700 of the sensor unit control register is set to the opposite of the value specified. In the hardware 0=on and 1=off.

#### 6.1.4.2.4.2 *Resulting Effect*

The resulting effect has three parts—(1) the software command is reflected in either Address Register 100 or the Sensor Unit Control Register (SUCR) control bits, (2) the change in temperature, voltage, etc., as measured by sensors, and (3) impact on the science data. Typical values are given below.

mm LNA Power Telecommand	Off	On
<b>Control Bits</b>		
SUCR, Bit 8 (NMRA0003, bit 7)**	1	0
<b>Sensor Results</b>		
+12V-2 Current SBEU*(NMRA0054)	0.56A	0.7A

\* The difference of roughly 0.014A should be observed. The absolute value depends on the rest of the state of the instrument

\*\* Note that the value of the SUCR Bit 8 has the inverse meaning of the command value.

The impact on the science data: The mm-wave continuum value goes to its “zero” counts level, about 1700.

#### 6.1.4.2.4.3 *Additional Information*

During initial software startup following power on or during a software restart to incorporate memory patches this value is set to on (0 in the SUCR).

#### 6.1.4.2.5 **RSDB Inputs**

Telecommand: ZMR19203 –MM LNA Power

Parameters: PMRG0009 –mm LNA Power, default 1, On  
 CMRV0005

0, off  
 1, on

### 6.1.4.3 Submillimeter LNA Power Telecommand Definition

#### 6.1.4.3.1 Description

This command turns the power on or off to the submillimeter-wave receiver low noise amplifier on the optical bench. The power is turned off in order to obtain a “zero” value for the submillimeter-wave continuum data calibration. This should be done at least once per submillimeter-wave continuum, dual continuum, or CTS/dual mode observing session.

#### 6.1.4.3.2 Packet Definition

Data Element	Size (bits)	Value (binary)	Comment
Version Number	3	000	EID-A Mandatory
Type	1	1	EID-A Mandatory
Data Field Header Flag	1	1	EID-A Mandatory
Application Process ID	7	1000111	EID-A Specified, 71
Packet Category	4	1100	EID-A Specified, Private (science) = 12
Sequence Flags	2	11	EID-A Mandatory
Sequence Count	14	000 + 1 up counter	First 3 bits are zero indicating 'Ground' as the source. The remaining 11 bits are zero initially, and constitute a one-up Telecommand counter. A separate counter is used for each APID/Packet Category combination.
Packet Length	16	000000000000111	This gets set to the size of the application data field (in bytes) + 5. In this case, 7.
PUS Version	3	000	EID-A Specified, Ground Sourced Telecommand
Checksum Flag	1	1	EID-A Mandatory
Ack	4	0001	EID-A Specified, Acknowledgement of Acceptance
Packet Type	8	11000000	EID-A Specified, Private Telecommand = 192
Packet Subtype	8	00001000	EID-A Optional, 8 = SMM LNA Power
Pad	8	00000000	EID-A Mandatory
Application Data	16	Variable	0-1 decimal: 0=Power Off, 1=Power On
Packet Error Control	16	Variable	Telecommand Packet Checksum

#### 6.1.4.3.3 Parameters

The parameters are given in the packet application data.

smm LNA power state (PMRG0010) : Power off=0, Power on = 1

Upon receipt of this TC the inbound FIFO manager task immediately clocks the specified setting out to the hardware.

##### 6.1.4.3.3.1 Action Taken

Bit 9 of address 700 of the sensor unit control register is set to the opposite of the value specified. In the hardware 0=on and 1=off.

6.1.4.3.3.2 *Resulting Effect*

The resulting effect has three parts—(1) the software command is reflected in either Address Register 100 or the Sensor Unit Control Register (SUCR) control bits, (2) the change in temperature, voltage, etc., as measured by sensors, and (3) impact on the science data. Typical values are given below.

<b>smm LNA Power Telecommand</b>	<b>Off</b>	<b>On</b>
<b>Control Bits</b>		
SUCR, Bit 9 (NMRA0003, bit 6)**	1	0
<b>Sensor Results</b>		
+12V-2 Current SBEU*(NMRA0054)	0.56A	0.7A

\* The difference of roughly 0.014A should be observed. The absolute value depends on the rest of the state of the instrument

\*\* Note that the value of the SUCR Bit 8 (9?) has the inverse meaning of the command value.

Impact on the science data: The submm-wave continuum level goes to its “zero” level, about 1700.

6.1.4.3.3.3 *Additional Information*

During initial software startup following power on or during a software restart to incorporate memory patches this value is set to on (0 in the SUCR).

**6.1.4.3.5 RSDB Inputs**

Telecommand: ZMR19204 –Submm LNA Power

Parameters: PMRG0010 –Submm LNA Power, default 1, On  
 CMRV0005

0, off  
 1, on

**6.1.5 ADDITIONAL SPECTROSCOPIC MODE TELECOMMANDS****6.1.5.1 IFP Power Control Telecommand****6.1.5.1.1 Description**

This telecommand sets the power level into the chirp transform spectrometer (CTS) coming out of the intermediate frequency processor (IFP). It can be adjusted in 1dB steps over a range of 16 dB. The power level for the hot mirror position during a calibration should be about 20000. This is a function of temperature since the gain of the system varies with temperature. At room temperature this is achieved with an IFP power setting of 3 dB.

Since this command changes the gain of the spectroscopic system a calibration sequence is automatically initiated when it is executed.

**6.1.5.1.2 Packet Definition**

Data Element	Size (bits)	Value (binary)	Comment
Version Number	3	000	EID-A Mandatory
Type	1	1	EID-A Mandatory
Data Field Header Flag	1	1	EID-A Mandatory
Application Process ID	7	1000111	EID-A Specified, 71
Packet Category	4	1100	EID-A Specified, Private (science) = 12
Sequence Flags	2	11	EID-A Mandatory
Sequence Count	14	000 + 1 up counter	First 3 bits are zero indicating 'Ground' as the source. The remaining 11 bits are zero initially, and constitute a one-up Telecommand counter. A separate counter is used for each APID/Packet Category combination.
Packet Length	16	000000000000111	This gets set to the size of the application data field (in bytes) + 5. In this case, 7.
PUS Version	3	000	EID-A Specified, Ground Sourced Telecommand
Checksum Flag	1	1	EID-A Mandatory
Ack	4	0001	EID-A Specified, Acknowledgement of Acceptance
Packet Type	8	11000000	EID-A Specified, Private Telecommand = 192
Packet Subtype	8	00000100	EID-A Optional, 4 = IFP Power Control
Pad	8	00000000	EID-A Mandatory
Application Data	16	Variable	0-15 decimal, specifies the IFP Power Control
Packet Error Control	16	Variable	Telecommand Packet Checksum

**6.1.5.1.3 Parameters**

The parameters are given in the packet application data.

IFP power level (PMRG0011): 0 = 0 dB, 1 = -1 dB, 2=-2db .....15=-15dB



## 6.1.5.1.4 Execution Description

Upon receipt of this TC the inbound FIFO manager task stores the setting in a global memory location. If the instrument is already running in a mode where the CTS is powered on the executive task initiates a mode change.

### 6.1.5.1.4.1 Action Taken

The executive task initiates a graceful shutdown of the software as part of a nominal mode change. Prior to performing an instrument calibration the IFP Power Control setting that was stored in global memory is clocked out to the hardware. Bits 6-7 and 13-14 of address 700 of the sensor unit control register are set to the value specified.

### 6.1.5.1.4.2 Resulting Effect

The resulting effect has three parts – 1) the software command is reflected in either Address Register 100 or the Sensor Unit Control Register (SUCR) control bits 2) the change in temperature, voltage, etc. as measured by sensors, and 3) impact on the science data. Typical values are given below.

IFP Power Control Telecommand	
<b>Control Bits</b>	
SUCR, Bit 6 (NMRA0003, bit 9)	Bit 0 of IFP Power Control
SUCR, Bit 7 (NMRA0003, bit 8)	Bit 1 of IFP Power Control
SUCR, Bit 13 (NMRA0003, bit 2)	Bit 2 of IFP Power Control
SUCR, Bit 14 (NMRA0003, bit 1)	Bit 3 of IFP Power Control
<b>Sensor Results</b>	
NA	

Impact on the science: Typical CTS spectra in the hot mirror position during the calibration sequence as a function of IFP Power Control values is given in the table below.

Value	Commanded IFP Level	Observed CTS Level	Measured Ratio to IFP Level =0	Ratio if Exactly 1 dB Change
3	-3db	19633		
0	0dB	36531	1	1
1	-1dB	31393	0.86	0.79
2	-2dB	24010	0.66	0.66
4	-4dB	15738	0.43	0.42
8	-8dB	5203	0.14	0.14
3	-3dB	19520	0.53	0.50

#### 6.1.5.1.4.3 *Additional Information*

The effect of the changing of the IFP Power Control is so great on the CTS data it was decided to have this command treated as if it were a mode change command. A graceful software shutdown is performed prior to implementing the new setting.

The IFP bits in the sensor unit control register are not tri-stated. When the CTS is not on these bits need to be set to 0. When the CTS is on, the global variable containing the IFP power level setting is clocked into the hardware shortly after the CTS is powered on. The powering on and off of the 4 IFP bits is now done in the power\_off and power\_on routines.

During initial software startup following power on or during a software restart to incorporate memory patches the global value is set to 3. The hardware is set to 0 because we come up in engineering mode by default.

#### 6.1.5.1.5 **RSDB Inputs**

Telecommand: ZMR19205 –IFP Power (RF) Control

Parameters: PMRG0011 –IFP Power Control, default 3, -3 dB

CMRV0006: 0, 0

1, -1 dB

2, -2 dB

3, -3 dB

4, -4 dB

5, -5 dB

6, -6 dB

7, -7 dB

8, -8 dB

9, -9 dB

10, -10 dB

11, -11 dB

12, -12 dB

13, -13 dB

14, -14 dB

15, -15 dB

## 6.1.5.2 Submillimeter Gunn Voltage Telecommand

### 6.1.5.2.1 Description

The Submillimeter Gunn Voltage Telecommand allows manual control of the submillimeter-wave Gunn oscillator voltage and hence frequency. This is desirable since the voltage that will result in the desired frequency is somewhat temperature dependent.

Note: This telecommand can be executed in the submillimeter continuum mode to control the frequency of the Gunn oscillator. However, in that case, the submillimeter Gunn oscillator is not controlled by the phase lock system.

### 6.1.5.2.2 Packet Definitions

Data Element	Size (bits)	Value (binary)	Comment
Version Number	3	000	EID-A Mandatory
Type	1	1	EID-A Mandatory
Data Field Header Flag	1	1	EID-A Mandatory
Application Process ID	7	1000111	EID-A Specified, 71
Packet Category	4	1100	EID-A Specified, Private (science) = 12
Sequence Flags	2	11	EID-A Mandatory
Sequence Count	14	000 + 1 up counter	First 3 bits are zero indicating 'Ground' as the source. The remaining 11 bits are zero initially, and constitute a one-up Telecommand counter. A separate counter is used for each APID/Packet Category combination.
Packet Length	16	0000000000000111	This gets set to the size of the application data field (in bytes) + 5. In this case, 7.
PUS Version	3	000	EID-A Specified, Ground Sourced Telecommand
Checksum Flag	1	1	EID-A Mandatory
Ack	4	0001	EID-A Specified, Acknowledgement of Acceptance
Packet Type	8	11000000	EID-A Specified, Private Telecommand = 192
Packet Subtype	8	00000001	EID-A Optional, 1 = SMM Gunn Voltage
Pad	8	00000000	EID-A Mandatory
Application Data	16	Variable	0-15 decimal, specifies the SMM Gunn Voltage
Packet Error Control	16	Variable	Telecommand Packet Checksum

### 6.1.5.2.3 Parameters

The telecommand parameter is given in the packet application data.

Submillimeter-wave Gunn voltage: one of sixteen values (0= 9.36V, 1= 9.29V, 2=9.23V, 3=9.16V, 4=9.09V, 5=9.02V, 6=8.95V, 7=8.88V, 8=8.81V, 9=8.74V, 10=8.67V, 11=8.60V, 12=8.53V, 13=8.46V, 14=8.39V, 15=8.32V)

#### 6.1.5.2.4 Execution Description

Upon receipt of this TC the inbound FIFO manager task immediately clocks the specified setting out to the hardware.

##### 6.1.5.2.4.1 Action Taken

Bits 0-3 of address 800 of the sensor unit control register are set to the value specified.

##### 6.1.5.2.4.2 Resulting Effect

The resulting effect has three parts—(1) the software command is reflected in either Address Register 100 or the Sensor Unit Control Register (SUCR) control bits, (2) the change in temperature, voltage, etc., as measured by sensors, and (3) impact on the science data. Typical values are given below.

<b>Submillimeter Gunn Voltage Telecommand</b>	
<b>Control Bits</b>	
SUCR, Bit 16 (NMRA0004, bit 15)	Bit 0 of smm Gunn osc. voltage
SUCR, Bit 17 (NMRA0004, bit 14)	Bit 1 of smm Gunn osc. voltage
SUCR, Bit 18 (NMRA0004, bit 13)	Bit 2 of smm Gunn osc. voltage
SUCR, Bit 19 (NMRA0004, bit 12)	Bit 3 of smm Gunn osc. voltage
<b>Sensor Results</b>	
SMM_PLL_ERR (NMRA0055)	Will become unlocked: Locked between 1.55V and 2.74V, Unlocked >2.74V or <1.55V (see typical data below)

The frequency of the Gunn oscillator changes with voltage and temperature. The variation with voltage has been measured to be +458.82 MHz/V over the range of commandable voltages. The voltage step size is 0.07V, corresponding to a change in 32.7 MHz at the Gunn oscillator frequency or 128 MHz at the sky frequency. At about room temperature telecommand of 4 =9.09V corresponds to the required frequency of 140703.3MHz. The resultant frequency for each commandable voltage based on this slope is given below.

The frequency also varies with temperature with a slope of 0.0037 V/C at 140.7 GHz. The absolute temperature is not well calibrated. In the table below we have set the voltage at 20°C to be that corresponding to a command of 4, the value observed to be locked at room temperature. Therefore this table provides trends. Based on this the command parameter values need to stay locked over the whole operating temperature range (−20°C to 40°C) is from 6 to 3.

Command	Voltage	Gunn Freq	LO Freq
0	9.36	140.8271	563.309
1	9.29	140.7905	563.180
2	9.23	140.7675	563.070
3	9.16	140.7354	562.941
4	9.09	140.7033	562.813
5	9.02	140.6711	562.685
6	8.95	140.6390	562.556
7	8.88	140.6069	562.428
8	8.81	140.5748	562.299
9	8.74	140.5427	562.171
10	8.67	140.5105	562.042
11	8.6	140.4784	561.914
12	8.53	140.4463	561.785
13	8.46	140.4142	561.657
14	8.39	140.3821	561.528
15	8.32	140.3500	561.400

Baseplate Temperature (°C)	Gunn Bias for 140.7 GHz (V)	Command
-20	8.95	6
-10	8.98	
0	9.02	5
10	9.05	
20	9.09	4
30	9.13	
40	9.17	3

\* 9.09 V is the nominal voltage for a sensor baseplate temperature in vacuum of 20°C

Note: 4 is nominal at for a sensor baseplate temperature of about 20°C in vacuum

Typical Phase Lock Error as a function of submillimeter-wave Gunn oscillator voltage at room temperature. The voltage for which lock is achieved is a function of temperature.

Value	Submm Gunn Voltage	SMM_PLL_ERR	State
start	9.09	1.6311	locked
0	9.36	3.1915	unlocked
3	9.16	2.5608	locked
4	9.09	1.5818	locked
5	9.02	0.4704	unlocked
6	8.95	0.3763	unlocked
9	8.74	3.0685	unlocked
12	8.53	3.0695	unlocked
15	8.32	3.0709	unlocked
12	8.53	3.0713	unlocked
9	8.74	3.0657	unlocked
6	8.95	0.37541	unlocked
5	9.02	0.4695	unlocked
4	9.09	1.6004	locked
3	9.16	2.532	locked
0	9.36	3.1896	unlocked
4 (nominal)	9.09	1.6516	locked

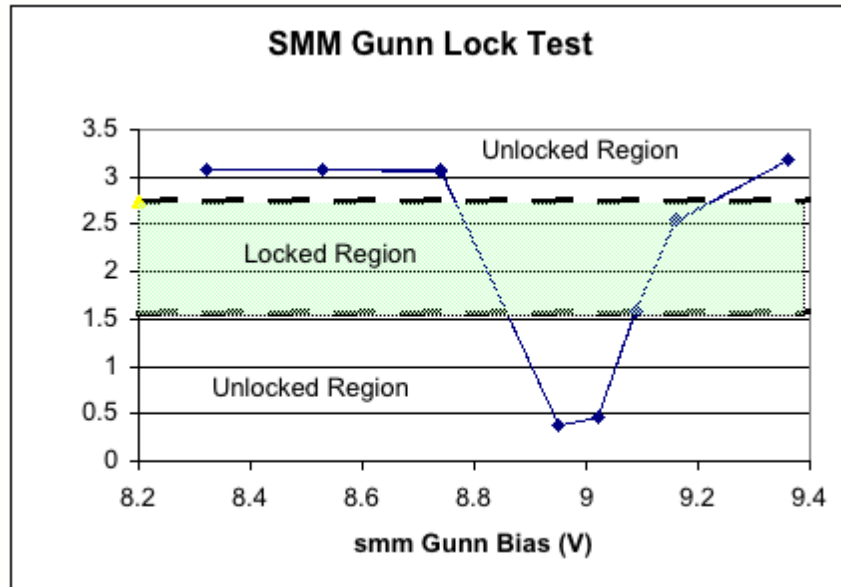

Note that the Gunn oscillator could be locked at two different voltages, though we have never seen it lock at the lower (wrong) voltage. Also there sometimes is hysteresis, though not seen here.

Impact on the science: The submillimeter-wave Gunn oscillator will become unlocked resulting in inaccurate frequency knowledge for the spectroscopic channels. The PLL alarm bits in the Spectroscopic (CTS) science data are set when the submillimeter-wave Gunn oscillator becomes unlocked. For more information see telemetry discussion in Section 6.2.3. Also the number of times that 6 PLL lock indicator bits were found to be locked and unlocked is stored in the Miscellaneous Science file under PLL lock successful counter and PLL Lock Unsuccessful counter.

#### 6.1.5.2.4.3 *Additional Information*

While this command can be used to directly set the SMM Gunn Voltage there are other commands that can affect the setting of the SMM Gunn Voltage value. The 'SMM Gunn Voltage Auto-control Enable/Disable' TC can enable automatic control by the software over this setting. See the description of that TC to see under what conditions the automatic control will change the setting. If the automatic control is disabled then any change made via this TC will stay in effect until a future change is made or automatic control is enabled.

During initial software startup following power on or during a software restart to incorporate memory patches this value is set to 4.

**6.1.5.2.5 RSDB Entries**

Telecommand: ZMR19201 – Submm Gunn Voltage

Parameters: PMRG0006 – Submm Gunn Voltage, default = 4 (9.09 V)

CMRV0003 =0-15  
0, 9.36V  
1, 9.29V  
2, 9.23V  
3, 9.16V  
4, 9.09V  
5, 9.02V  
6, 8.95V  
7, 8.88V  
8, 8.81V  
9, 8.74V  
10, 8.67V  
11, 8.60V  
12, 8.53V  
13, 8.46V  
14, 8.39V  
15, 8.32V





#### 6.1.5.3.4.2 Resulting Effect

The resulting effect has three parts—(1) the software command is reflected in either Address Register 100 or the Sensor Unit Control Register (SUCR) control bits, (2) the change in temperature, voltage, etc., as measured by sensors, and (3) impact on the science data. Typical values are given below.

<b>PLL Reset Telecommand</b>	
<b>Control Bits</b>	
SUCR, Bit 12 (NMRA0003, bit 3)	Phase-lock Reset (0 locks, 1 unlocks)
<b>Sensor Results</b>	
SMM_PLL_ERR (NMRA0055)	Locked between 1.55V and 2.74V, Unlocked >2.74V or <1.55V (see typical data in previous command)

Impact on the science: The submillimeter-wave Gunn oscillator will become unlocked resulting in inaccurate frequency knowledge for the spectroscopic channels. The PLL alarm bits in the Spectroscopic (CTS) science data are set when the submillimeter-wave Gunn oscillator becomes unlocked. For more information see telemetry discussion in Section 6.2.3. Also the number of times that 6 PLL lock indicator bits were found to be locked and unlocked is stored in the Miscellaneous Science file under PLL lock successful counter and PLL Lock Unsuccessful counter.

#### 6.1.5.3.4.3 Additional Information

This TC was originally implemented to toggle the affected bit upon receipt of the TC. It was changed to be a high or low setting.

During initial software startup following power on or during a software restart to incorporate memory patches this value is set to 0.

#### 6.1.5.3.5 RSDB Inputs

Telecommand: ZMR19207 –Reset PLL

Parameters: PMRG0013 –PLL Reset, default 0, Off  
CMRV0005

0, off  
1, on

**6.1.5.4 SMM Gunn Voltage Auto-control Enable/Disable Telecommand****6.1.5.4.1 Description**

MIRO is automated to adjust the submillimeter-wave Gunn oscillator voltage to stay locked over temperature. This command either enables or disables this capability.

**6.1.5.4.2 Packet Definition**

Data Element	Size (bits)	Value (binary)	Comment
Version Number	3	000	EID-A Mandatory
Type	1	1	EID-A Mandatory
Data Field Header Flag	1	1	EID-A Mandatory
Application Process ID	7	1000111	EID-A Specified, 71
Packet Category	4	1100	EID-A Specified, Private (science) = 12
Sequence Flags	2	11	EID-A Mandatory
Sequence Count	14	000 + 1 up counter	First 3 bits are zero indicating 'Ground' as the source. The remaining 11 bits are zero initially, and constitute a one-up Telecommand counter. A separate counter is used for each APID/Packet Category combination.
Packet Length	16	0000000000000111	This gets set to the size of the application data field (in bytes) + 5. In this case, 7.
PUS Version	3	000	EID-A Specified, Ground Sourced Telecommand
Checksum Flag	1	1	EID-A Mandatory
Ack	4	0001	EID-A Specified, Acknowledgement of Acceptance
Packet Type	8	11000000	EID-A Specified, Private Telecommand = 192
Packet Subtype	8	00010101	EID-A Optional, 21 = SMM Gunn Voltage auto-control enable/disable
Pad	8	00000000	EID-A Mandatory
Application Data	16	Variable	0-1: 0=auto-control disabled, 1=auto-control enabled
Packet Error Control	16	Variable	Telecommand Packet Checksum

**6.1.5.4.3 Parameters**

The parameter is found in the packet application data.

SMM Gunn Volt Enbl/Dsbl (PMRG0029): 1= Enable (default), 0 = disable

**6.1.5.4.4 Execution Description**

Upon receipt of this TC the inbound FIFO manager task sets a global variable that controls further processing by other tasks.

**6.1.5.4.4.1 Action Taken**

When the auto-control capability is disabled the software control of the SMM Gunn Voltage works as follows:

1. SMM Gunn Voltage set to 4 following every power on or software restart.
2. Following CTS internal table initialization the SMM Gunn Voltage is set to 3.
3. The SMM Gunn Voltage setting is increased by 1.
4. If the last setting was 15 the SMM Gunn Voltage is set to 0.
5. A 1-second delay occurs.
6. The PLL Phase Error engineering measurement is sampled.
7. If the PLL Phase Error lies between 1.55V (0x680) and 2.74V (0xb80) the SMM Gunn Voltage is left at the current value and processing continues.
8. If the PLL Phase Error falls outside the range then go to step 3.
9. If the desired PLL Phase Error is not achieved after 32 iterations the software exits the loop and processing continues with the SMM Gunn Voltage set to 4.

Following this the SMM Gunn Voltage remains at its last set value until it is either manually changed via TC or the instrument is repowered or the software is restarted.

When the auto-control capability is enabled the software control of the SMM Gunn Voltage works as follows:

1. The same processing occurs as described in steps 1–9 above.
2. Just prior to each instrument calibration if we are running in a mode where the CTS is powered on the PLL Phase Error is again checked to see if it falls within the 1.55V (0x680) to 2.74 (0xb80) range.
3. If the value is < 1.55V (0x680) the SMM Gunn Voltage is decreased by 1.
4. If the value is > 2.74V (0xb80) the SMM Gunn Voltage is increased by 1.
5. Processing then continues with an instrument calibration.

#### 6.1.5.4.4.2

#### *Resulting Effect*

When enabled, approximately every 30 minutes (instrument calibration) the SMM Gunn Voltage may be adjusted 1 count either up or down to automatically compensate for temperature-induced drift in the hardware.

The resulting effect has three parts—(1) the software command is reflected in either Address Register 100 or the Sensor Unit Control Register (SUCR) control bits, (2) the change in temperature, voltage, etc., as measured by sensors, and (3) impact on the science data. Typical values are given below.

<b>Submillimeter Gunn Voltage Telecommand</b>	
<b>Control Bits</b>	
SUCR, Bit 16 (NMRA0004, bit 15)	Bit 0 of smm Gunn osc. voltage
SUCR, Bit 17 (NMRA0004, bit 14)	Bit 1 of smm Gunn osc. voltage
SUCR, Bit 18 (NMRA0004, bit 13)	Bit 2 of smm Gunn osc. voltage
SUCR, Bit 19 (NMRA0004, bit 12)	Bit 3 of smm Gunn osc. voltage

Impact on the science: If the submillimeter-wave Gunn oscillator becomes unlocked then the frequency knowledge for the spectroscopic channels becomes inaccurate. The PLL alarm bits in the Spectroscopic (CTS) science data are set when the submillimeter-wave Gunn oscillator becomes unlocked. For more information see telemetry discussion in Section 6.2.3. Also the number of times that 6 PLL lock indicator bits were found to be locked and unlocked is stored in the Miscellaneous Science file under PLL lock successful counter and PLL Lock Unsuccessful counter.

#### 6.1.5.4.4.3 *Additional Information*

As per the above pseudo-code the SMM Gunn Voltage will only be changed at most 1 setting in either direction. And the change will only occur just prior to each instrument calibration, nominally every 30 minutes.

During initial software startup following power on or during a software restart to incorporate memory patches the auto control of the SMM Gunn Voltage is enabled.

#### 6.1.5.4.5 **RSDB Inputs**

Telecommand: ZMR19223 – SMM Gunn Voltage AutoCtrl Enable/Disable

Parameters: PMRG0029 – SMM Gunn Volt Enbl/Dsbl, default = 1, Enable  
CMRV0021  
0, Disable  
1, Enable

## 6.1.5.5 CTS Heater Control Telecommand

### 6.1.5.5.1 Description

The analog part (SAW filters) of the CTS is temperature controlled. For optimum performance of the thermal feedback analog part of the CTS should be at least 20C above ambient. This command allows you to set the temperature that the analog part of the CTS will be controlled to. In addition, the power level available for this thermal control can be specified. This latter control allows a trade between power dissipation and time to reach a certain temperature.

This command can be executed only in spectroscopic modes. In a non-spectroscopic mode the CTS warmup telecommand should be used to change the temperature for the thermal control.

### 6.1.5.5.2 Packet Definition

Data Element	Size (bits)	Value (binary)	Comment
Version Number	3	000	EID-A Mandatory
Type	1	1	EID-A Mandatory
Data Field Header Flag	1	1	EID-A Mandatory
Application Process ID	7	1000111	EID-A Specified, 71
Packet Category	4	1100	EID-A Specified, Private (science) = 12
Sequence Flags	2	11	EID-A Mandatory
Sequence Count	14	000 + 1 up counter	First 3 bits are zero indicating 'Ground' as the source. The remaining 11 bits are zero initially, and constitute a one-up Telecommand counter. A separate counter is used for each APID/Packet Category combination.
Packet Length	16	000000000000111	This gets set to the size of the application data field (in bytes) + 5. In this case, 7.
PUS Version	3	000	EID-A Specified, Ground Sourced Telecommand
Checksum Flag	1	1	EID-A Mandatory
Ack	4	1001	EID-A Optional, Acknowledgement of Acceptance and Acknowledgement of Execution
Packet Type	8	11000000	EID-A Specified, Private Telecommand = 192
Packet Subtype	8	00000110	EID-A Optional, 6 = CTS Heater Control
Pad	8	00000000	EID-A Mandatory
Application Data	16	Variable	Detailed definition on following page
Packet Error Control	16	Variable	Telecommand Packet Checksum

### CTS Heater Control Telecommand Application Data Definition

Data Element	Size (bits)	Value (binary)	Comment
CTS Heater Power	4		0=High, 1=Off, 2=Low
CTS Heater Temperature	4		All values are degrees C; 0=0, 1=10, 2=20, 3=30, 4=40, 5=50, 6=60, 7=70
Reserved	8		Not Used

**6.1.5.5.3 Parameters**

The parameters are contained in the application data of the packet.

CTS Heater Temperature (PMRD2101): 0, 10, 20, 30, 40, 50, 60, 70

CTS Heater Power (PMRD2102): High, Off, Low

**6.1.5.5.4 Execution Description**

Upon receipt of this TC the inbound FIFO manager task stores the CTS heater setting in a global variable and immediately clocks the specified setting out to the CTS.

*6.1.5.5.4.1 Action Taken*

A CTS command is built that contains the value specified in the application data field of the TC and sent to the CTS.

*6.1.5.5.4.2 Resulting Effect*

The CTS power level and temperature setting are sent to the CTS and the CTS will begin to heat up to the required temperature using the level of power specified.

The resulting effect has three parts—(1) the software command is reflected in either Address Register 100 or the Sensor Unit Control Register (SUCR) control bits, (2) the change in temperature, voltage, etc. as measured by sensors, and (3) impact on the science data. The direct effect of this is that the thermal control for the analog SAW filters of the CTS is turned on and set to the input temperature. The heating rate is determined by the power level. There are 6 temperature sensors in the CTS. Spect Temp 1–4 are in the analog part. Spect Temp 5–6 are in the digital part. The first four temperatures should stabilize at the commanded temperatures. The last 2 temperatures will increase by about 5–10°C. The supply voltage and current also change. The typical effect on telemetry is summarized below.

CTS Warm Up Telecommand	Off	On
<b>Control Bits (already set by change mode)</b>		
<b>Sensor Results</b>		
Spect Temp #1 (analog) (NMRA0009)	ambient	commanded temperature
Spect Temp #2 (analog) (NMRA0010)	ambient	commanded temperature
Spect Temp #3 (analog) (NMRA0011)	ambient	commanded temperature
Spect Temp #4 (analog) (NMRA 0012)	ambient	commanded temperature
Spect Temp #5 (digital) (NMRA0013)	ambient	ambient + 5C
Spect Temp #6 (digital) (NMRA0014)	ambient	ambient + 5C
+12V EU (NMRA0016)	13.20V	12.29V
+12V Curr EU (NMRA0022)	0.07A	0.31 (lo) – 0.51A (hi)

Impact on the science data: There is no easily measured impact on the science data. The CTS spectroscopic data will be more stable when the CTS SAW filters are maintained at a constant temperature.

#### 6.1.5.5.4.3 *Additional Information*

The default setting of the global variable that contains the CTS temperature and power level is 30°C and low power. The default setting of the global variable takes place when either the instrument is powered on or a software restart TC is processed. The setting of the CTS heater temperature and power level in the CTS itself does not take place until the CTS is turned on. In the case where this TC is used to set the CTS temperature and power global variable, that setting will remain in effect (in memory) even when the instrument is put into a mode where the CTS is powered off. Upon entering a mode where the CTS is again powered on the global variable will be used to set the CTS temperature and power level to the previous setting.

If the CTS is not powered on and this TC is sent to the instrument the software will not execute.

During initial software startup following power on or during a software restart to incorporate memory patches this internally stored value is set to 30° C and low power.

#### 6.1.5.5.5 **RSDB Inputs**

Telecommand: ZMR19215 – CTS Heater Controls

Parameters: PMRG0021 – CTS Heater Control

PMRD2101 – CTS Heater Temperature, default = 10C  
CMRV0016

- 0, 0 deg
- 1, 10 deg
- 2, 20 deg
- 3, 30 deg
- 4, 40 deg
- 5, 50 deg
- 6, 60 deg
- 7, 70 deg

PMRD2102 – CTS Heater Power, default = Low Power  
CMRV0017

- 0, High Power
- 1, Off
- 2, Low Power

PMRD2103 – Not Used

### 6.1.5.6 CTS Internal Calibration Telecommand

#### 6.1.5.6.1 Description

The CTS uses four banks of analog-to-digital converters (ADCs) to generate the 4096 spectral channels. Each of the 4 banks of ADCs contains 2 high speed 8-bit ADCs. The output of the ADC banks are interspersed so that the 1st channel comes from the 1<sup>st</sup> ADC bank, the 2<sup>nd</sup> channel from the 2<sup>nd</sup> ADC bank, the 3<sup>rd</sup> channel from the 3<sup>rd</sup> ADC bank and the 4<sup>th</sup> channel from the 4<sup>th</sup> ADC bank. The pattern of repeating, interspersed ADC banks continues through all 4096 channels. Each of the 8 individual ADCs has a different offset and gain that may drift with time and temperature. The purpose of the CTS internal calibration is to compensate for these differences.

Since the CTS internal calibration invalidates the instrument calibration, the CTS internal calibration telecommand actually does two things: (1) the actual CTS internal calibration followed by (2) a new instrument calibration.

A CTS internal calibration is performed automatically every time that the CTS is powered on. (A mode change telecommand to a spectroscopic mode will not perform a CTS internal calibration if the instrument is already in a spectroscopic mode.) This telecommand was created to allow for a re-calibration at least once a day to compensate for any temperature or power level induced changes in the CTS functioning during multi-day CTS observing periods. Once the CTS internal calibration and instrument calibrations are complete, the instrument automatically resumes in the spectroscopic mode it was in before the command was invoked.

The CTS internal calibration command should not be used unless the instrument is already operating in a spectroscopic mode. If the instrument receives a CTS internal calibration command when it is not in spectroscopic mode the command will be rejected.

#### 6.1.5.6.2 Packet Definition

Data Element	Size (bits)	Value (binary)	Comment
Version Number	3	000	EID-A Mandatory
Type	1	1	EID-A Mandatory
Data Field Header Flag	1	1	EID-A Mandatory
Application Process ID	7	1000111	EID-A Specified, 71
Packet Category	4	1100	EID-A Specified, Private (science) = 12
Sequence Flags	2	11	EID-A Mandatory
Sequence Count	14	000 + 1 up counter	First 3 bits are zero indicating 'Ground' as the source. The remaining 11 bits are zero initially, and constitute a one-up Telecommand counter. A separate counter is used for each APID/Packet Category combination.
Packet Length	16	0000000000000111	This gets set to the size of the application data field (in bytes) + 5. In this case, 7.



Data Element	Size (bits)	Value (binary)	Comment
PUS Version	3	000	EID-A Specified, Ground Sourced Telecommand
Checksum Flag	1	1	EID-A Mandatory
Ack	4	1001	EID-A Optional, Acknowledgement of Acceptance and Acknowledgement of Execution
Packet Type	8	11000000	EID-A Specified, Private Telecommand = 192
Packet Subtype	8	00010001	EID-A Optional, 17 = CTS Internal Calibration
Pad	8	00000000	EID-A Mandatory
Application Data	16	Variable	Anything
Packet Error Control	16	Variable	Telecommand Packet Checksum

### 6.1.5.6.3 Parameters

This telecommand requires no parameters.

### 6.1.5.6.4 Execution Description

The inbound FIFO manager task sets a variable in global memory for use by the executive task. The inbound FIFO manager task then sets the mode\_change semaphore to notify the executive task that a mode change has been commanded. The executive task checks for a mode change once per second while in the nominal processing loop.

#### 6.1.5.6.4.1 Action Taken

Upon detection of a CTS internal calibration command the executive task begins a graceful shutdown of the software in the current mode of operation. The current CTS integration is allowed to complete. All collected science TM data is processed and flushed out to the outbound FIFO manager task as part of the graceful shutdown. Then the command causes a CTS internal calibration and an instrument calibration to be carried out. Upon completion of the command the executive task resumes the operation of the software in the same operational mode as before the command had been received.

This CTS uses as a sum of squares (SOS) look-up table as part of its processing. The SOS table is an (x,y) square 256 x 256 in size. There are four of these SOS tables, one for each ADC bank of two ADCs each. The center of the table contains 0. Proceeding outward from the center the cells are populated by the values  $(x^2+y^2)$  as shown in the partially filled table below.

	32				16				32
		18			9			18	
			8	5	4	5	8		
			5	2	1	2			
	16	9	4	1	0	1	4	9	16
			5	2	1	2	5		
			8	5	4	5	8		
		18			9			18	
	32				16				32

If the ADC is perfect, with no offset, then the center of the table will be at (128, 128). The effect of an offset is to shift the table center. The CTS internal calibration procedure determines the effective center (also called midpoint) for each of the 8 ADCs. The four SOS tables are then generated with the 0 being placed in the effective center. These four SOS tables, each with their own midpoints, are then loaded into the CTS.

A two-step process is used in order to measure the effective center of a SOS table for each ADC bank. The first step determines the x center, the second the y center. To determine the x-axis center, the SOS table is loaded with a linear ramping pattern, so that each column of the table contains the same data in each row. The CTS executes 10,000 cycles and the data is read out of the CTS. A linear SOS table loaded for calculating the x-axis midpoint is shown below.

	124	125	126	127	128	129	130	131	132
	124	125	126	127	128	129	130	131	132
	124	125	126	127	128	129	130	131	132
	124	125	126	127	128	129	130	131	132
	124	125	126	127	128	129	130	131	132
	124	125	126	127	128	129	130	131	132
	124	125	126	127	128	129	130	131	132
	124	125	126	127	128	129	130	131	132
	124	125	126	127	128	129	130	131	132

Again if the ADC were perfect, the average of the output of the CTS when scaled for the number of cycles would be 127.5. However, since it is not perfect the output would be different, say 126.7. This is then the computed midpoint for the x-axis ADC. Since the SOS table can only be loaded with integer values the calculated floating point table midpoint is rounded to the nearest integer value prior to subsequently computing the actual SOS table values.

A linear SOS table loaded for calculating the y-axis midpoint is shown below. A similar scheme is used, but in this case the SOS table is loaded with the linear ramping pattern in the rows not the columns.

	124	124	124	124	124	124	124	124	124	
	125	125	125	125	125	125	125	125	125	
	126	126	126	126	126	126	126	126	126	
	127	127	127	127	127	127	127	127	127	
	128	128	128	128	128	128	128	128	128	
	129	129	129	129	129	129	129	129	129	
	130	130	130	130	130	130	130	130	130	
	131	131	131	131	131	131	131	131	131	
	132	132	132	132	132	132	132	132	132	

Again if the ADC were perfect, the average of the output of the CTS when scaled for the number of cycles would be 127.5. However, since it is not perfect the output would be different, say 124.2. This is then the computed midpoint for the y-axis. After rounding, 124 would be used as the mid-point for computing the actual SOS table.

The two rounded midpoints for each SOS table are then used to determine the cell that contains the value 0. The entire SOS table is then generated around the zero point until the entire table is filled in as described earlier.

#### 6.1.5.6.4.2 *Resulting Effect*

The x and y midpoints of the 4 sum-of-squares tables are downlinked in the miscellaneous science TM packet that gets generated immediately after the CTS internal calibration is complete. There are two midpoints for each table, one representing the real part of the transform, the other the imaginary part. The values of the midpoints should be about 128 if the inherent offset of the ADC banks is exactly centered with regard to a null input signal.

#### 6.1.5.6.4.3 *Additional Information*

The CTS contains 4 internal sum of squares tables which are 256x256 16-bit values. These are loaded with data calculated by the flight computer and then transferred to the CTS. The CTS uses them to process the CTS spectrum. The process of determining what values to load into the sum-of-squares tables prior to nominal data collection is the CTS internal calibration process.

The CTS does not turn on correctly if its operating temperature is below about  $-5^{\circ}\text{C}$ . When this occurs the one or more of CTS internal calibration midpoints are orders of magnitude larger than the expected value of around 127. When temperatures are this low the CTS warm up command should be used prior to entering any spectroscopic mode.

**6.1.5.6.5 RSDB Inputs**

Telecommand: ZMR19216 – CTS Internal Calibration

Parameters: PMRG0022 – CTS Internal Calibration

### 6.1.5.7 CTS Data Masks Telecommand

#### 6.1.5.7.1 Description

The CTS generates spectra that consist of 4096 channels of 32-bit data. The flight software compresses the 32-bits to 12-bits. The default compression algorithm looks for the channel with the largest value. It identifies the high bit associated with this value and then makes that the most significant bit for all the channels by stripping off the higher bits with zero value. Then it goes down 12 bits below this high bit and strips off the lower bits.

This telecommand manually sets the high bit above which bits are stripped. The CTS spectra are a composite of 7 bands. Each band may have significantly different gains. In addition, calibration data and regular differenced data have very different values. Therefore a total of 14 most significant bits can be set, one for calibration data in each band and 1 for regular differenced data in each band.

#### 6.1.5.7.2 Packet Definition

Data Element	Size (bits)	Value (binary)	Comment
Version Number	3	000	EID-A Mandatory
Type	1	1	EID-A Mandatory
Data Field Header Flag	1	1	EID-A Mandatory
Application Process ID	7	1000111	EID-A Specified, 71
Packet Category	4	1100	EID-A Specified, Private (science) = 12
Sequence Flags	2	11	EID-A Mandatory
Sequence Count	14	000 + 1 up counter	First 3 bits are zero indicating 'Ground' as the source. The remaining 11 bits are zero initially, and constitute a one-up Telecommand counter. A separate counter is used for each APID/Packet Category combination.
Packet Length	16	0000000000010011	This gets set to the size of the application data field (in bytes) + 5. In this case, 19.
PUS Version	3	000	EID-A Specified, Ground Sourced Telecommand
Checksum Flag	1	1	EID-A Mandatory
Ack	4	0001	EID-A Specified, Acknowledgement of Acceptance
Packet Type	8	11000000	EID-A Specified, Private Telecommand = 192
Packet Subtype	8	00010010	EID-A Optional, 18 = CTS Data Masks
Pad	8	00000000	EID-A Mandatory
Application Data	112	Variable	Detailed definition on following page
Packet Error Control	16	Variable	Telecommand Packet Checksum

## CTS Data Masks Telecommand Application Data Definition

Data Element	Size (bits)	Value (binary)	Comment
Calibration band #1 MSB	8	Varies	Valid setting is in the range of 11-31
Calibration band #2 MSB	8	Varies	Valid setting is in the range of 11-31
Calibration band #3 MSB	8	Varies	Valid setting is in the range of 11-31
Calibration band #4 MSB	8	Varies	Valid setting is in the range of 11-31
Calibration band #5 MSB	8	Varies	Valid setting is in the range of 11-31
Calibration band #6 MSB	8	Varies	Valid setting is in the range of 11-31
Calibration band #7 MSB	8	Varies	Valid setting is in the range of 11-31
Nominal band #1 MSB	8	Varies	Valid setting is in the range of 11-31
Nominal band #2 MSB	8	Varies	Valid setting is in the range of 11-31
Nominal band #3 MSB	8	Varies	Valid setting is in the range of 11-31
Nominal band #4 MSB	8	Varies	Valid setting is in the range of 11-31
Nominal band #5 MSB	8	Varies	Valid setting is in the range of 11-31
Nominal band #6 MSB	8	Varies	Valid setting is in the range of 11-31
Nominal band #7 MSB	8	Varies	Valid setting is in the range of 11-31

### 6.1.5.7.3 Parameters

The parameters are given in the packet application data definition.

The value assigned to the parameters is an integer in the range from 11 to 31.

- (PMRD2301) Calibration Band#1 MSB
- (PMRD2302) Calibration Band#2 MSB
- (PMRD2303) Calibration Band#3 MSB
- (PMRD2304) Calibration Band#4 MSB
- (PMRD2305) Calibration Band#5 MSB
- (PMRD2306) Calibration Band#6 MSB
- (PMRD2307) Calibration Band#7 MSB
- (PMRD2308) Nominal Band#1 MSB
- (PMRD2309) Nominal Band#2 MSB
- (PMRD2310) Nominal Band#3 MSB
- (PMRD2311) Nominal Band#4 MSB
- (PMRD2312) Nominal Band#5 MSB
- (PMRD2313) Nominal Band#6 MSB
- (PMRD2314) Nominal Band#7 MSB

### 6.1.5.7.4 Execution Description

The inbound FIFO manager task parses the 14 mask values out of the TC and populates a global array that will be used by the CTS final processing task.

#### 6.1.5.7.4.1 *Action Taken*

Following the population of the global mask array the inbound FIFO manager task generates a miscellaneous science TM packet containing, among other things, the current set of mask values.

#### 6.1.5.7.4.2 *Resulting Effect*

Immediately following the processing of the TC and the setting of the global mask variables all CTS data sets that are generated will reflect the use of the masks.

Typical values for the most significant bit by the autonomous compression routine are MSB=25 for calibration data and MSB=17 for regular differenced data. The value of the MSB for the calibration data depends on the IFP power setting. The value for the MSB for the regular differenced data depends on the noise in the spectrum (integration time, receiver temperature). The autonomous value is stored in the spectroscopic (CTS) science source data packet and named CTS multiplier value. Note that the 11 must be added to this value to get the number to input into this command. Therefore if the multiplier value is 12, then to get the same effect the input to this command is 23. When this command is executed the multiplier value is set to 0 and the user-defined values are placed in the miscellaneous science file.

If the most significant bit of one band is increased by one bit, then it will appear a factor of two smaller when compared to the other bands.

#### 6.1.5.7.4.3 *Additional Information*

CTS data sets generated as a result of an uplinked mask are identified by having the 'CTS Multiplier Value' data element set to zero. In this case the masks sent out in the most recent miscellaneous science TM packet must be used to expand the raw 12-bit CTS values out to their actual size.

Once a CTS data mask has been uplinked there is no way to 'drop back' to using the auto calculated value for CTS data set MSB determination. The only way to get back to that mode of operation is to issue a software restart command or repower the instrument.

During initial software startup following power on or during a software restart to incorporate memory patches the mask values for the 7 calibration bands are set to 0, and the 7 nominal bands are set to 11. Also, auto calculation of the MSB of each data set is re-enabled.

### 6.1.5.7.5 **RSDB Inputs**

Telecommand: ZMR19217 – CTS Data Masks

Parameters: PMRG2301 –Define CTS Data Masks #1  
PMRD2301 Calibration Band#1 MSB

## CMRV0018

11, MSB=11  
12, MSB=12  
13, MSB=13  
14, MSB=14  
15, MSB=15  
16, MSB=16  
17, MSB=17  
18, MSB=18  
19, MSB=19  
20, MSB=20  
21, MSB=21  
22, MSB=22  
23, MSB=23  
24, MSB=24  
25, MSB=25  
26, MSB=26  
27, MSB=27  
28, MSB=28  
29, MSB=29  
30, MSB=30  
31, MSB=31

PMRD2302 Calibration Band#2 MSB  
CMRV0018

PMRD2303 Calibration Band#3 MSB  
CMRV0018

PMRD2304 Calibration Band#4 MSB  
CMRV0018

PMRD2305 Calibration Band#5 MSB  
CMRV0018

PMRD2306 Calibration Band#6 MSB  
CMRV0018

PMRG2302 – Define CTS Data Masks #2

PMRD2307 Calibration Band#7 MSB  
CMRV0018

PMRD2308 Nominal Band#1 MSB  
CMRV0018

PMRD2309 Nominal Band#2 MSB  
CMRV0018

PMRD2310 Nominal Band#3 MSB  
CMRV0018

PMRD2311 Nominal Band#4 MSB  
CMRV0018



PMRD2312 Nominal Band#5 MSB

CMRV0018

PMRG2303 - Define CTS Data Masks #3

PMRD2313 Nominal Band#6 MSB

CMRV0018

PMRD2314 Nominal Band#7 MSB

CMRV0018

**6.1.5.8 CTS Run Time Telecommand**

**6.1.5.8.1 Description**

This telecommand is used to minimize overhead in the timing when both the spectroscopic and continuum data are being collection (i.e., during spectroscopic modes—CTS/Smm Continuum and CTS/Dual continuum modes). The objective is to reduce that gap from its worse case of 500 milliseconds to about 20 milliseconds, by increasing the CTS run time.

The continuum and spectrometer detailed timeline is given below. The figure shows the detail at the end of a 5 sec LO frequency switch. During each ~5 seconds CTS scan, 100 continuum samples are read out. A time gap is introduced between the time when the 100<sup>th</sup> continuum sample is read out and the next 5 second CTS scan is started. The reason for introducing this gap is that there is an uncertainty in the continuum sample readout of +/-1%, which means that the 100<sup>th</sup> sample could be readout anywhere between 4.95 and 5.05 seconds. The CTS run time is programmable by this telecommand. Its default setting is 4.95 seconds, the minimum time for the 100<sup>th</sup> continuum sample to be read out. This is returned in the Miscellaneous Science data. Also the time to readout the CTS data is uncertain, between 230 and 500 milliseconds. When the program starts up the worse case is assumed, that both the 100<sup>th</sup> sample is read out at 4.95 seconds and the CTS readout takes 500 milliseconds. The next CTS scan and continuum

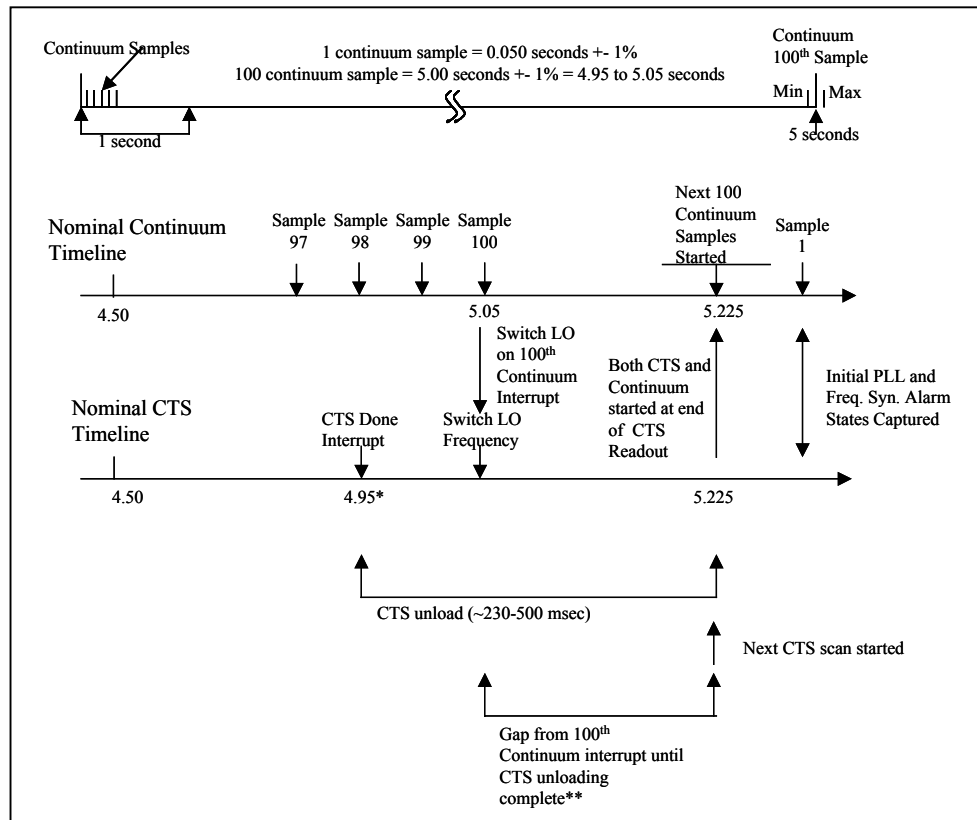

readout then start at 5.225 sec. The gap, called the continuum/CTS unloading gap, from the actual 100<sup>th</sup> continuum interrupt until the actual CTS readout is complete is returned in the Miscellaneous science file.

### 6.1.5.8.2 Packet Definition

Data Element	Size (bits)	Value (binary)	Comment
Version Number	3	000	EID-A Mandatory
Type	1	1	EID-A Mandatory
Data Field Header Flag	1	1	EID-A Mandatory
Application Process ID	7	1000111	EID-A Specified, 71
Packet Category	4	1100	EID-A Specified, Private (science) = 12
Sequence Flags	2	11	EID-A Mandatory
Sequence Count	14	000 + 1 up counter	First 3 bits are zero indicating 'Ground' as the source. The remaining 11 bits are zero initially, and constitute a one-up Telecommand counter. A separate counter is used for each APID/Packet Category combination.
Packet Length	16	0000000000000111	This gets set to the size of the application data field (in bytes) + 5. In this case, 7.
PUS Version	3	000	EID-A Specified, Ground Sourced Telecommand
Checksum Flag	1	1	EID-A Mandatory
Ack	4	0001	EID-A Specified, Acknowledgement of Acceptance
Packet Type	8	11000000	EID-A Specified, Private Telecommand = 192
Packet Subtype	8	00001100	EID-A Optional, 12 = CTS run time setting
Pad	8	00000000	EID-A Mandatory
Application Data	16	Variable	Detailed definition on following page
Packet Error Control	16	Variable	Telecommand Packet Checksum

### CTS Run Time Telecommand Application Data Definition

Data Element	Size (bits)	Value (binary)	Comment
Large Multiplier	1		When set to 1, multiply the results obtained from the small multiplier by an additional 256.
Small Multiplier	1		When set to 1, multiply the integration counts field by 16.
Integration Counts	14	Varies	Integration counts. Each count equals ~22.35 microseconds.

### 6.1.5.8.3 Parameters

The telecommand parameters are identified in the packet application data definition.

Large multiplier (PMRD1601): 0, 1 – multiply small multiplier by  $256^{\text{largemultiplier}}$ , default = 0.

Small multiplier (PMRD1602): 0, 1 – multiply integration counts by  $16^{\text{smallmultiplier}}$ ,

default = 1.

Integration counts (PMRD1603): default = 13858 (each count = ~22.35 microseconds).

#### 6.1.5.8.4 Execution Description

Upon receipt of this TC the inbound FIFO manager task immediately clocks the specified setting out to the hardware. The internal variable that is used to keep track of the average CTS scan times is zeroed as this command directly affects the CTS scan duration. The internal variable that is used to track the minimum duration from the 100<sup>th</sup> continuum interrupt being received until the CTS readout complete is also initialized to 10.0 as increasing or decreasing the CTS run time will directly affect this value. Both of these values appear as TM in the miscellaneous science packet.

##### 6.1.5.8.4.1 Action Taken

The global variable that is used to control the CTS integration cycle count is set to the specified value.

The CTS scan duration, beginning with the next CTS integration, will be set to the number of cycles specified in the global variable. The global variable will remain set to the specified value until either (1) power down/up (2) software restart (3) receipt of new CTS Run Time command.

##### 6.1.5.8.4.2 Resulting Effect

The CTS scan duration will be set to the number of cycles specified. The 100<sup>th</sup> continuum cycle is read out in a range from 4.95 seconds to 5.05 seconds. The time for the CTS data to unload is from 0.19 to 0.50 seconds. Then the range for the gap as a function of CTS run time is given in the Table below. The gap should not be less than 0.02 seconds. As you can see from the table below the range for the CTS run time is between 4.956 (default from large multiplier =0, small multiplier = 1, integration counts = 13858) and 4.47 seconds (large multiplier = 0, small multiplier =1, integration counts =12499).

Large Multiplier	0	0	0	0	0	0	0
Small Multiplier	1	1	1	1	1	1	1
Integration Counts	13858	13701	13422	13142	12863	12583	12499
CTS Run Time (sec)	4.956	4.9	4.8	4.7	4.6	4.5	4.47
Max Gap (sec)	0.506	0.45	0.35	0.25	0.15	0.05	0.02
Min Gap (sec)	0.096	0.04	-0.06	-0.16	-0.26	-0.36	-0.39

The CTS Run time and continuum/CTS unloading gap in seconds are read out in the Miscellaneous Science file. The Gap is initially set to 10.0 to indicate when it hasn't been updated.

The CTS is considered to have failed if the busy line of the CTS is still high during the 100<sup>th</sup> continuum interrupt processing. The busy line normally goes low at the completion of the CTS scan. If the busy line stays high, a graceful software shutdown will occur returning the instrument to the engineering mode. A *CTS Error Event Report (YMR00015)* will be generated.

#### 6.1.5.8.4.3 *Additional Information*

Operationally this TC should be used to decrease the 'continuum / CTS unloading gap' value in the miscellaneous science packet down to a value of about 0.020 seconds.

A short experiment indicates that for the case where

Large multiplier = 0,  
Small multiplier = 1, and  
Integration Counts = 13620

results in a gap of .02 seconds. This implies that the CTS unloading time is just under 0.2 seconds. This however should be verified in flight.

The methodology for doing this should be as follows. A miscellaneous science packet is generated every 30 minutes of nominal operation as part of the instrument calibration. The 'continuum / CTS unloading gap' should be monitored in each of the miscellaneous science packets that get generated at 30 minute intervals due to instrument calibration. Miscellaneous science packets also get generated for a variety of other reasons, and the 'continuum / CTS unloading gap' values in those TM packets should not be used. When the 'continuum / CTS unloading gap' as reported in the miscellaneous science packet stops decreasing over time the value should be noted. Assume that the value has stabilized at 0.100 seconds. The CTS run time will now need to be adjusted to a lower value in order to decrease the 'continuum / CTS unloading gap'. Its CTS run time should not be lowered to a value to immediately reduce the gap from 0.100 to the desired 0.020 value, but gradually decreased over perhaps 3 or 4 iterations. If we wanted to lower it from 0.100 to 0.050 we would need to decrease the CTS run time by about 2272 cycles ( $0.050 / 0.000022$ ). The CTS run time would then be changed from the nominal value of 30242 (221728 cycles) to 30100 (219456 cycles). The 'continuum / CTS unloading gap' should then be monitored until it stops decreasing again, and the process repeated to lower the gap closer to the desired value of 0.020. Once the process has been repeated several times and the gap has been reduced to the 0.020 level the CTS run time being used should be noted. This CTS run time should then be uplinked via TC every time the instrument is repowered or restarted to implement a memory patch. This is the CTS run time that should be used for long-term operation. Once this process has been completed the 'continuum / CTS unloading gap' should still be monitored over time to insure that it maintains the 0.020 nominal level. Further small adjustments may be required over time due to temperature, power or other variables.

During initial software startup following power on or during a software restart to incorporate memory patches this value is set to 30242. The 30242 corresponds to 0x7622. Bit 14 serves as an indicator to multiply the value specified in bits 0-13 by 16. Bit 15 serves as an indicator to further multiple the resulting value by an additional 256. The initial setting of 0x7622 represents  $0x3622 * 0x10$  which totals 221728. This number is the number of cycles that the CTS is set to run for, where each cycle is approximately 22.35 microseconds duration.

#### 6.1.5.8.5 RSDB Inputs

Telecommand: ZMR19210 – CTS Run Time

Parameters: PMRG0016 – CTS Run Time

PMRD1601 – Large Multiplier  
CMRV0008

0, 0

1, SmlMultx256

PMRD1602 – Small Multiplier  
CMRV0009

0,0

1, IntCntsx16

PMRD1603 – Integration Counts

**6.1.5.9 CTS Pulse Position Telecommand****6.1.5.9.1 Description**

This telecommand translates the CTS spectrum with respect to channel number, by approximately 4 spectral channels per unit change in the pulse position number. The default position is 410. This telecommand would allow adjustment of the frequency offset that might result from a change in the CTS function. This is not anticipated.

**6.1.5.9.2 Packet Definition**

Data Element	Size (bits)	Value (binary)	Comment
Version Number	3	000	EID-A Mandatory
Type	1	1	EID-A Mandatory
Data Field Header Flag	1	1	EID-A Mandatory
Application Process ID	7	1000111	EID-A Specified, 71
Packet Category	4	1100	EID-A Specified, Private (science) = 12
Sequence Flags	2	11	EID-A Mandatory
Sequence Count	14	000 + 1 up counter	First 3 bits are zero indicating 'Ground' as the source. The remaining 11 bits are zero initially, and constitute a one-up Telecommand counter. A separate counter is used for each APID/Packet Category combination.
Packet Length	16	0000000000000111	This gets set to the size of the application data field (in bytes) + 5. In this case, 7.
PUS Version	3	000	EID-A Specified, Ground Sourced Telecommand
Checksum Flag	1	1	EID-A Mandatory
Ack	4	1001	EID-A Optional, Acknowledgement of Acceptance and Acknowledgement of Execution
Packet Type	8	11000000	EID-A Specified, Private Telecommand = 192
Packet Subtype	8	00001101	EID-A Optional, 13 = CTS pulse position setting
Pad	8	00000000	EID-A Mandatory
Application Data	16	Variable	See CTS ICD for additional information
Packet Error Control	16	Variable	Telecommand Packet Checksum

**6.1.5.9.3 Parameters**

CTS pulse position (PMRG0017) = 410 (default)

**6.1.5.9.4 Execution Description**

Upon receipt of this TC the inbound FIFO manager task immediately clocks the specified setting out to the CTS.

#### 6.1.5.9.4.1 *Action Taken*

A CTS command is built that contains the value specified in the application data field of the TC and sent to the CTS.

#### 6.1.5.9.4.2 *Resulting Effect*

There is no telemetry that indicates the value of the pulse position. However, it turns out that there is an internal “birdie” in the instrument that results in a signal at 1364.7 MHz when the CTS pulse position is set to 410 (default). The effect of this telecommand is to translate the spectrum with respect to channel number by approximately 4 channels/unit change. So, for instance when the CTS pulse position is set to 510, the birdie will move 400 channels (each channel is about 43 kHz wide) to 1347.5 MHz.

#### 6.1.5.9.4.3 *Additional Information*

The CTS pulse position is only sent out to the CTS at two times. When the CTS internal tables are calibrated this is sent out just prior to the start of that processing. When the TC itself is received the value is also clocked out to the CTS. The value received in the TC is stored internally and used during subsequent internal CTS calibrations.

If the CTS is not powered on and this TC is sent to the instrument the software will fail in a manner that is TBD.

During initial software startup following power on or during a software restart to incorporate memory patches this internally stored value is set to 410 and used when a CTS internal calibration takes place.

### **6.1.5.9.5 RSDB Inputs**

Telecommand: ZMR19211 – CTS Pulse Position

Parameters: PMRG0017 – CTS Pulse Position, default = 410



## 6.1.6 CALIBRATION MIRROR CONTROL TELECOMMANDS

### 6.1.6.1 Move Mirror Telecommand

#### 6.1.6.1.1 Description

This telecommand will move the calibration mirror to any of its preset positions – space, hot load, and cold load.

#### 6.1.6.1.2 Packet Definition

Data Element	Size (bits)	Value (binary)	Comment
Version Number	3	000	EID-A Mandatory
Type	1	1	EID-A Mandatory
Data Field Header Flag	1	1	EID-A Mandatory
Application Process ID	7	1000111	EID-A Specified, 71
Packet Category	4	1100	EID-A Specified, Private (science) = 12
Sequence Flags	2	11	EID-A Mandatory
Sequence Count	14	000 + 1 up counter	First 3 bits are zero indicating 'Ground' as the source. The remaining 11 bits are zero initially, and constitute a one-up Telecommand counter. A separate counter is used for each APID/Packet Category combination.
Packet Length	16	0000000000000111	This gets set to the size of the application data field (in bytes) + 5. In this case, 7.
PUS Version	3	000	EID-A Specified, Ground Sourced Telecommand
Checksum Flag	1	1	EID-A Mandatory
Ack	4	0001	EID-A Specified, Acknowledgement of Acceptance
Packet Type	8	11000000	EID-A Specified, Private Telecommand = 192
Packet Subtype	8	01100110	EID-A Optional, 102 = Move Mirror
Pad	8	00000000	EID-A Mandatory
Application Data	16	Variable	1-3 decimal: 1=Space, 2=Hot Target, 3=Cold Target
Packet Error Control	16	Variable	Telecommand Packet Checksum

#### 6.1.6.1.3 Parameters

The parameter is given in the packet application data.

Move Mirror (PMRG0018): 1 = space (default), 2= hot load, 3= cold load

#### 6.1.6.1.4 Execution Description

Upon receipt of this TC the inbound FIFO manager task sets a semaphore that activates the memory check task. The memory check task performs the actual moving of the mirror as required by the command.

##### 6.1.6.1.4.1 Action Taken

The mirror is moved from its current location to the specified location.

6.1.6.1.4.2 *Resulting Effect*

The resulting effect has three parts—(1) the software command is reflected in either Address Register 100 or the Sensor Unit Control Register (SUCR) control bits, (2) the change in temperature, voltage, etc., as measured by sensors, and (3) impact on the science data.

Calibration Heater Telecommand	Off	On
<b>Control Bits</b>		
SUCR, Bit 28 (NMRA0004, bit 3)*	1	0
SUCR, Bit 29 (NMRA0004, bit 2)*		0=forward, 1=backward
SUCR, Bit 31 (NMRA0004, bit 0)*		Set and clear to activate pin puller
<b>Sensor Results</b>		
Mirror Location (NMRA00006)		1=sky, 2=hot, 3=cold
+24 V EU (NMRA0020)*		See spike
+24 V Current (NMRA0026)*		See spike

\*May be ob for less than 11 sec, so engineering data may miss it

The impact on the science data:

The mirror location is returned with the CTS Science source data, the Submillimeter Continuum Source Data, and the Millimeter Continuum Source Data.

Event Reports:

Failure of the mirror returns event reports

- *Mirror Error Type 1 (YMR00002)* is generated when the mirror fails to achieve the desired position, but is then successfully driven back to its mechanical stop and then positioned at space.
- *Mirror Error Type 2 (YMR00003)* is generated when the mirror fails to achieve the desired position, is then driven back to its mechanical stop and then fails to find space position.
- *Mirror Error Type 3 (YMR00004)* is generated when the mirror fails to achieve the desired position, is then driven back to its mechanical stop and then fails to find the space position, the pin puller is activated and the space position located successfully.
- *Mirror Error Type 4 (YMR00005)* is generated when the mirror fails to achieve the desired position, is then driven back and then fails to find the space position, the pin puller is activated and the space position is not located.
- *Mirror Error Type 5 (YMR00006)* is generated when the previous mirror failure was recovered from and was followed by a subsequent failure.

#### 6.1.6.1.4.3 *Additional Information*

The memory check task is used to perform the mirror movement because the movement requires several seconds of time to execute, and we do not want to delay the processing of the inbound FIFO manager task while that is taking place.

Mirror movement fault protection is in place during the mirror movement. I.e. Any failure to reach the desired location will result in recovery actions taking place. A pin puller releases the mirror and it is returned to the mechanical stop position by a spring. The pin puller is then re-engaged.

Once manually moved via this command the mirror will remain in the location specified, unless manually moved again, until the next instrument calibration occurs. At that time the mirror will be automatically moved by the software to support instrument calibration. At the end of the instrument calibration the mirror will be pointing to the space location.

During initial software startup following power on or during a software restart to incorporate memory patches the mirror is driven back to the mechanical stop and moved forward until it reaches the space position.

#### 6.1.6.1.5 **RSDB Inputs**

Telecommand: ZMR19212 – Move Mirror

Parameters: PMRG0018 – Move Mirror, default = space  
                  CMRV0011

- 1, space
- 2, hot
- 3, cold

**6.1.6.2 Step Mirror Telecommand**

**6.1.6.2.1 Description**

The Step mirror command moves the mirror the commanded number of steps in either the forward (from mechanical stop) or backward (toward mechanical stop) direction.

The calibration mirror is driven by a stepping motor with 0.27-degree step size. The space position is near the mechanical stop. The hot load is 41 (152 steps) degrees from the space position, while the cold load is 23 (85 steps) degrees from the hot load. The calibration loads are 5 cm in diameter. The hot load is located approximately 8 cm from the calibration mirror while the cold load is located about 28 cm from the calibration mirror. Therefore the hot load half angle at the calibration mirror is roughly 17 (63 steps) degrees, while the cold load half angle at the mirror is about 5 degrees (18 steps). These angles are shown in Figure 1.

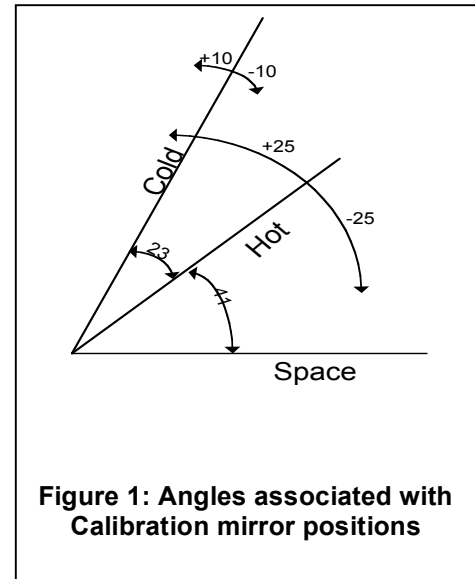

**Figure 1: Angles associated with Calibration mirror positions**

**6.1.6.2.2 Packet Definition**

Data Element	Size (bits)	Value (binary)	Comment
Version Number	3	000	EID-A Mandatory
Type	1	1	EID-A Mandatory
Data Field Header Flag	1	1	EID-A Mandatory
Application Process ID	7	1000111	EID-A Specified, 71
Packet Category	4	1100	EID-A Specified, Private (science) = 12
Sequence Flags	2	11	EID-A Mandatory
Sequence Count	14	000 + 1 up counter	First 3 bits are zero indicating 'Ground' as the source. The remaining 11 bits are zero initially, and constitute a one-up Telecommand counter. A separate counter is used for each APID/Packet Category combination.
Packet Length	16	000000000000111	This gets set to the size of the application data field (in bytes) + 5. In this case, 7.
PUS Version	3	000	EID-A Specified, Ground Sourced Telecommand
Checksum Flag	1	1	EID-A Mandatory
Ack	4	0001	EID-A Specified, Acknowledgement of Acceptance
Packet Type	8	11000000	EID-A Specified, Private Telecommand = 192
Packet Subtype	8	00010100	EID-A Optional, 20 = Step Mirror
Pad	8	00000000	EID-A Mandatory
Application Data	16	Variable	Detailed definition on following page
Packet Error Control	16	Variable	Telecommand Packet Checksum

## Step Mirror Telecommand Application Data Definition

Data Element	Size (bits)	Value (binary)	Comment
Movement Direction	8		0=forward, 1=backward
Number of steps	8		0-255

### 6.1.6.2.3 Parameters

Mirror movement direction (PMRD2801): 0 = forward (from space to hot to cold), 1= backwards (from cold to hot to space)

Number of steps (PMRD2802): 0 – 255 (note 237 steps will go from space to cold)

### 6.1.6.2.4 Execution Description

Upon receipt of this TC the inbound FIFO manager task sets a semaphore that activates the memory check task. The memory check task performs the actual stepping of the mirror as required by the command.

#### 6.1.6.2.4.1 Action Taken

The mirror is moved a series of single steps from its current location in the specified direction.

#### 6.1.6.2.4.2 Resulting Effect

The resulting effect has three parts – 1) the software command is reflected in either Address Register 100 or the Sensor Unit Control Register (SUCR) control bits 2) the change in temperature, voltage, etc. as measured by sensors, and 3) impact on the science data.

Calibration Heater Telecommand	Off	On
<b>Control Bits</b>		
SUCR, Bit 28 (NMRA0004, bit 3)*	1	0
SUCR, Bit 29 (NMRA0004, bit 2)*		0=forward, 1=backward
SUCR, Bit 31 (NMRA0004, bit 0)*		Set and clear to activate pin puller
<b>Sensor Results</b>		
+24 V EU (NMRA0020)*		See spike
+24 V Current (NMRA0026)*		See spike

\*May be for less than 11 sec, so engineering data may miss it

#### 6.1.6.2.4.3 Additional Information

The memory check task is used to perform the mirror movement because the movement could require several seconds of time to execute, and we do not want



## 6.1.7 SOFTWARE TELECOMMANDS

### 6.1.7.1 Software Restart Telecommand

#### 6.1.7.1.1 Description

The software restart telecommand is used for several purposes: (1) to implement a patch that has been loaded by the load memory telecommand, (2) to reset parameters, such as the CTS mask parameters to default, without turning off the whole instrument, and 3) to restart the system if for some reason it is not responding.

This command should be implemented while in engineering mode.

#### 6.1.7.1.2 Packet Definition

Data Element	Size (bits)	Value (binary)	Comment
Version Number	3	000	EID-A Mandatory
Type	1	1	EID-A Mandatory
Data Field Header Flag	1	1	EID-A Mandatory
Application Process ID	7	1000111	EID-A Specified, 71
Packet Category	4	1100	EID-A Specified, Private (science) = 12
Sequence Flags	2	11	EID-A Mandatory
Sequence Count	14	000 + 1 up counter	First 3 bits are zero indicating 'Ground' as the source. The remaining 11 bits are zero initially, and constitute a one-up Telecommand counter. A separate counter is used for each APID/Packet Category combination.
Packet Length	16	000000000000111	This gets set to the size of the application data field (in bytes) + 5. In this case, 7.
PUS Version	3	000	EID-A Specified, Ground Sourced Telecommand
Checksum Flag	1	1	EID-A Mandatory
Ack	4	0001	EID-A Specified, Acknowledgement of Acceptance
Packet Type	8	11000000	EID-A Specified, Private Telecommand = 192
Packet Subtype	8	01100111	EID-A Optional, 103 = Software Restart
Pad	8	00000000	EID-A Mandatory
Application Data	16	Variable	Anything
Packet Error Control	16	Variable	Telecommand Packet Checksum

#### 6.1.7.1.3 Parameters

S/W Pwr Down (PMRG0019 ): value isn't used for anything

#### 6.1.7.1.4 Execution Description

Upon receipt of this TC the inbound FIFO manager task sets a semaphore that is acted upon by the executive assembly. The executive assembly checks the setting of the restart semaphore once per second when running in the nominal processing

loop. When the executive sees that the restart semaphore has been set it begins the processing required to restart the software.

#### 6.1.7.1.4.1 *Action Taken*

The executive assembly deletes all created tasks, message queues and semaphores prior to exiting. The patch executive task detects that the executive task has terminated and processes the entire set of memory patches that exist. The software is then restarted with all memory patches in effect.

#### 6.1.7.1.4.2 *Resulting Effect*

All memory patches uplinked since the last power on will be in effect once the software restarts.

#### 6.1.7.1.4.3 *Additional Information*

The executive assembly does not check the software restart semaphore during instrument calibration processing. Because of this the restart command should only be sent while the instrument is in engineering mode.

From the time that the inbound FIFO task manager receives the software restart command until the restart processing is complete and the software is back up and running is approximately 10 seconds. During this time no TCs should be sent to the instrument, as there is no software running to process them.

All internally buffered data within the instrument awaiting collection by the spacecraft will be lost during the software restart.

A software restart results in the same initial state as when the instrument is first powered on. No uplinked settings for any commandable items are retained through the software restart.

#### 6.1.7.1.5 **RSDB Inputs**

Telecommand: ZMR19213 – Software Restart

Parameters: PMRG0019 – S/W Pwr Down (Grnd Test)



## 6.1.7.2 Memory Checksum Telecommand

### 6.1.7.2.1 Description

This telecommand will carryout a checksum of the memory specified in the parameters. It does a complete checksum of memory, but only a partial checksum (every other word) of the eepprom.

### 6.1.7.2.2 Packet Definition

Data Element	Size (bits)	Value (binary)	Comment
Version Number	3	000	EID-A Mandatory
Type	1	1	EID-A Mandatory
Data Field Header Flag	1	1	EID-A Mandatory
Application Process ID	7	1000111	EID-A Specified, 71
Packet Category	4	1100	EID-A Specified, Private (science) = 12
Sequence Flags	2	11	EID-A Mandatory
Sequence Count	14	000 + 1 up counter	First 3 bits are zero indicating 'Ground' as the source. The remaining 11 bits are zero initially, and constitute a one-up Telecommand counter. A separate counter is used for each APID/Packet Category combination.
Packet Length	16	0000000000001101	This gets set to the size of the application data field (in bytes) + 5. In this case, 13.
PUS Version	3	000	EID-A Specified, Ground Sourced Telecommand
Checksum Flag	1	1	EID-A Mandatory
Ack	4	0001	EID-A Specified, Acknowledgement of Acceptance
Packet Type	8	00000110	EID-A Specified, Memory Management = 6
Packet Subtype	8	00001001	EID-A Specified, 9 = Check Memory
Pad	8	00000000	EID-A Mandatory
Application Data	64	Variable	Detailed definition on following page
Packet Error Control	16	Variable	Telecommand Packet Checksum

### Memory Checksum Telecommand Application Data Definition

Data Element	Size (bits)	Value (binary)	Comment
Memory ID	8	01100100	100 = MIROs assigned ID
Number of blocks	8	00000001	Must be 1.
Start address	32	Variable	Must be quadword aligned. RAM range is 0x00000000 through 0x01FFFFFF. ROM range is 0xFF800000 through 0xFF8FFFFFF.
Block Length	16	Variable	Number of quadwords (32 bit words) to check. 64k-1 maximum quadwords.

### 6.1.7.2.3 Parameters

The parameters are given in the telecommand application data.  
 The two that can be set are:

- Start address (PMRG0002): for patch uploads a candidate is 0x300000, the RAM range is 0x0000000 through 0x1FFFFFF, for EEPROM the range is 0xFF800000 through 0xFF8FFFFFF and in 0x8000 long sections this is 0xFF800000, 0xFF820000, 0xFF840000, 0xFF860000, 0xFF880000, 0xFF8A0000, 0xFF8C0000, 0xFF8E0000.
- Block length (PMRG0003): the number of quadwords (32 bit words) to check.

#### 6.1.7.2.4 Execution Description

Upon receipt of this TC the inbound FIFO manager task sets a semaphore to tell the memory check task to perform the memory checksum processing.

##### 6.1.7.2.4.1 Action Taken

The memory check task performs the checksum over the specified address range of ROM or RAM memory. For the ROM the checksum is incomplete, checking only every other quadword.

##### 6.1.7.2.4.2 Resulting Effect

A TM packet (YMR00008) is generated in response to this TC that contains the final memory checksum calculated.

Start Address	NMRAST51	copied from TC
Block Length	NMRAST52	copied from TC
Checksum	NMRAST54	

Note: The checksums for the EEPROM start addresses above are in table below.

Start Address	Checksum
0xFF800000	0xDE39
0xFF820000	0xA511
0xFF840000	0x74DB
0xFF860000	0xCC56
0xFF880000	0x0A8B
0xFF8A0000	0xBEFC
0xFF8C0000	0x3743
0xFF8E0000	0x84C0

##### 6.1.7.2.4.3 Additional Information

The checksum algorithm used is the ESA standard as defined in the EID-A document.

**6.1.7.2.5 RSDB Inputs**

Telecommand: ZMR00603 – Check MIRO Memory

Parameters: PMRG0001 –Memory Block  
                  PMRD0101 – Memory ID, default = 100  
                  PMRD0102 – Blocks, default = 1  
PMRG0002 – Memory Start  
PMRG0003 – Memory Length

### 6.1.7.3 Memory Dump Telecommand

#### 6.1.7.3.1 Description

This telecomm and will dump out either RAM or EEPROM memory of a commandable length starting at a commandable location.

#### 6.1.7.3.2 Packet Definition

Data Element	Size (bits)	Value (binary)	Comment
Version Number	3	000	EID-A Mandatory
Type	1	1	EID-A Mandatory
Data Field Header Flag	1	1	EID-A Mandatory
Application Process ID	7	1000111	EID-A Specified, 71
Packet Category	4	1100	EID-A Specified, Private (science) = 12
Sequence Flags	2	11	EID-A Mandatory
Sequence Count	14	000 + 1 up counter	First 3 bits are zero indicating 'Ground' as the source. The remaining 11 bits are zero initially, and constitute a one-up Telecommand counter. A separate counter is used for each APID/Packet Category combination.
Packet Length	16	0000000000001101	This gets set to the size of the application data field (in bytes) + 5. In this case, 13.
PUS Version	3	000	EID-A Specified, Ground Sourced Telecommand
Checksum Flag	1	1	EID-A Mandatory
Ack	4	0001	EID-A Specified, Acknowledgement of Acceptance
Packet Type	8	00000110	EID-A Specified, Memory Management = 6
Packet Subtype	8	00000101	EID-A Specified, 5 = Dump Memory
Pad	8	00000000	EID-A Mandatory
Application Data	64	Variable	Detailed definition on following page
Packet Error Control	16	Variable	Telecommand Packet Checksum

#### Memory Dump Telecommand Application Data Definition

Data Element	Size (bits)	Value (binary)	Comment
Memory ID	8	01100100	100 = MIRO's assigned ID
Number of blocks	8	00000001	Must be 1.
Start address	32	Variable	Must be quadword aligned. RAM range is 0x00000000 through 0x01FFFFFF. ROM range is 0xFF800000 through 0xFF8FFFFFF.
Block Length	16	Variable	Number of quadwords (32 bit words) to check. 64k-1 maximum quadwords.

#### 1.6.7.3.3 Parameters

The parameters are given in the telecommand application data.

The two that can be set are

- Start address (PMRG0002): the RAM range is 0x0000000 through 0x1FFFFFFF, for EEPROM the range is 0xFF800000 through 0xFF8FFFFFFF.
- Block length (PMRG0003): the number of quadwords (32 bit words) to dump.

#### 6.1.7.3.4 Execution Description

Upon receipt of this TC the inbound FIFO manager task sets a semaphore to tell the memory check task to perform the memory dump processing.

##### 6.1.7.3.4.1 Action Taken

The memory check task performs the dump of the specified address range of ROM or RAM memory.

##### 6.1.7.3.4.2 Resulting Effect

One or more memory dump TM packets (YMR00007) are generated in response to this TC that contains the memory contents of the requested area.

Start Address	NMRAST51	copied from TC
Block Length	NMRAST52	copied from TC
Memory Data	NMRAST53	Contents of dump

##### 6.1.7.3.4.3 Additional Information

The memory dump request can specify as many as 256k bytes of data, 64k quadwords. Memory dump TM packets are created with the largest size allowed by the EID-A specification.

Memory dump TM packets are trickled out at a rate of one per collection cycle of the DMS. If the DMS collection cycle is every 8 seconds then a 256k byte dump contained in 65 TM packets will be output in 520 seconds.

Only the first memory dump telemetry packet contains all the header information—this therefore requires separate handling by ESOC. Specifically the Memory ID field type should contain “sub-type 6” which defines the format of the memory dump telemetry packets. The second and subsequent packets of each memory dump do not have this information.

The message queue data structure in the outbound FIFO manager task that is used to hold the memory dump TM packets is sized to hold no more than 65 packets. A memory dump of the maximum allowable 256k bytes of memory should not be performed until it is known that the data structure is empty. The message queue associated with the dump TM packets needs to be managed as a consumable resource, in that memory dumps should not be requested that would generate more TM packets than are available in the queue at that time. Since it is not anticipated that the memory dump TC will be used very frequently this should not be difficult to do.

Since the dump parameters (start address, end address, etc) are stored in global memory by the inbound FIFO manager task for use by the memory check task another precaution must be taken. Processing of the memory dump request and generation of the TM packets requires 20 or 30 seconds of clock time by the memory check task. During this time it is important that another memory dump, memory checksum or memory load command not be sent as the memory dump that is in progress will be corrupted.

The simplest way to avoid any problems with memory checksum and memory dump processing is to wait for the associated TM data to be sent out of the instrument. At that point it is safe to send the next such request.

#### **6.1.7.3.5 RSDB Inputs**

Telecommand: ZMR00602 – Dump MIRO Memory

Parameters:    PMRG0001 –Memory Block  
                  PMRD0101 – Memory ID, default = 100  
                  PMRD0102 – Blocks, default = 1  
                  PMRG0002 – Memory Start  
                  PMRG0003 – Memory Length

## 6.1.7.4 Memory Load Telecommand

### 6.1.7.4.1 Description

The memory load telecommand loads a patch into an intermediate storage location. Note that the load command does not actually patch memory.

The procedure for patching requires the following sequence.

1. Execute the load memory telecommand—this places the patch in a temporary location
2. Execute the stop the time update telecommand
3. Execute the software restart telecommand—the patch is loaded into its proper location
4. Execute the start time update telecommand
5. Execute the check memory telecommand on the proper location – this determines if the patch is successfully loaded.

### 6.1.7.4.2 Packet Definition

Data Element	Size (bits)	Value (binary)	Comment
Version Number	3	000	EID-A Mandatory
Type	1	1	EID-A Mandatory
Data Field Header Flag	1	1	EID-A Mandatory
Application Process ID	7	1000111	EID-A Specified, 71
Packet Category	4	1100	EID-A Specified, Private (science) = 12
Sequence Flags	2	11	EID-A Mandatory
Sequence Count	14	000 + 1 up counter	First 3 bits are zero indicating 'Ground' as the source. The remaining 11 bits are zero initially, and constitute a one-up Telecommand counter. A separate counter is used for each APID/Packet Category combination.
Packet Length	16	Variable	This gets set to the size of the application data field (in bytes) + 5.
PUS Version	3	000	EID-A Specified, Ground Sourced Telecommand
Checksum Flag	1	1	EID-A Mandatory
Ack	4	0001	EID-A Specified, Acknowledgement of Acceptance
Packet Type	8	00000110	EID-A Specified, Memory Management = 6
Packet Subtype	8	00000010	EID-A Specified, 2 = Load Memory
Pad	8	00000000	EID-A Mandatory
Application Data	64	Variable	Detailed definition on following page
Packet Error Control	16	Variable	Telecommand Packet Checksum

## Memory Load Telecommand Application Data Definition

Data Element	Size (bits)	Value (binary)	Comment
Memory ID	8	01100100	100 = MIRO's assigned ID
Number of blocks	8	00000001	Must be 1.
Start address	32	0	Not used by software as part of memory loading but must pass address validation check. Hence the forced zero.
Block Length	16	Variable	Number of quadwords (32 bit words) that follow in the data block field. If the data block exceeds the maximum TC packet size it must be split up into more than 1 TC.
Data Block	Varies	Variable	Contains memory load information.

**6.1.7.4.3 Parameters**

The parameters are given in the telecommand application data.

The three that can be set are

- Start address (PMRG0002): not used, however needs to have value to pass formatting check
- Block length (PMRG0003): the number of quadwords (32 bit words) to load,
- Data block (PMRG0004): the 1<sup>st</sup> quadword contains the memory address where the patch is to be loaded following a software restart (0x00300000 was used during SVT), the second quadword is the number of quadwords of data that follow, and the subsequent quadwords the data to be loaded into memory.

**6.1.7.4.4 Execution Description**

Upon receipt of this TC the inbound FIFO manager task populates the main patch area of memory with the contents of the data block field.

*6.1.7.4.4.1 Action Taken*

The data from the 'Data Block' area of the TC is appended to the current contents of the patch array in global memory. The amount of data to be appended is solely based on the 'Block Length' field. The 'Start Address' field of the TC is not applicable as the patch data is loaded sequentially into this pre-defined area of memory.

*6.1.7.4.4.2 Resulting Effect*

The contents of the current TC are appended to all accumulated memory patches.

*6.1.7.4.4.3 Additional Information*

All unlinked patches will be incorporated into the instrument upon receipt of a software restart command.



**6.1.7.4.5 RSDB Inputs**

Telecommand: ZMR00601 – Load MIRO Memory

Parameters: PMRG0001 – Memory Block  
PMRD0101 – Memory ID, default = 100  
CMRV0002  
100,100  
PMRD0102 – Blocks, default = 1  
PMRG0002 – Memory Start  
PMRG0003 – Memory Length  
PMRG0004 – MemData

## 6.1.8 S/C INTERFACE TELECOMMANDS

### 6.1.8.1 Enable MIRO HK Generation Telecommand

#### 6.1.8.1.1 Description

This telecommand starts MIRO engineering housekeeping data transfer to the 'outbound fifo management task' for transmission to the SC.

#### 6.1.8.1.2 Packet Definition

Data Element	Size (bits)	Value (binary)	Comment
Version Number	3	000	EID-A Mandatory
Type	1	1	EID-A Mandatory
Data Field Header Flag	1	1	EID-A Mandatory
Application Process ID	7	1000111	EID-A Specified, 71
Packet Category	4	1100	EID-A Specified, Private (science) = 12
Sequence Flags	2	11	EID-A Mandatory
Sequence Count	14	000 + 1 up counter	First 3 bits are zero indicating 'Ground' as the source. The remaining 11 bits are zero initially, and constitute a one-up Telecommand counter. A separate counter is used for each APID/Packet Category combination.
Packet Length	16	0000000000000111	This gets set to the size of the application data field (in bytes) + 5. In this case, 7.
PUS Version	3	000	EID-A Specified, Ground Sourced Telecommand
Checksum Flag	1	1	EID-A Mandatory
Ack	4	0001	EID-A Specified, Acknowledgement of Acceptance
Packet Type	8	11000000	EID-A Specified, Housekeeping Reporting=3
Packet Subtype	8	00000100	EID-A Optional, 5=Enable HK Report Generation
Pad	8	00000000	EID-A Mandatory
Application Data	16	Variable	PAD=1, Structure ID=1
Packet Error Control	16	Variable	Telecommand Packet Checksum

#### 6.1.8.1.3 Parameters

PAD (PMRDSID1) = 1 (default)

Structure ID (PMRDSID2): identifier of which HK report to be acted on =1 (MIRO has only one HK report)

#### 6.1.8.1.4 Execution Description

##### 6.1.8.1.4.1 Action Taken

On receipt MIRO starts generation of the HK report. The engineering housekeeping collection task is running and collecting engineering data whenever MIRO is on. It packetizes the data too. This occurs every 11.3 seconds unless the

engineering housekeeping cycle skip telecommand has been executed. The only effect that turning the HK generation on is that the housekeeping data is transferred to the 'outbound fifo management task' for transmission to the SC.

6.1.8.1.4.2 *Resulting Effect*

Generation of MIRO Housekeeping Data packets (YMR00001) is enabled (see section 6.2.2 for description).

**6.1.8.1.5 RSDB Inputs**

Telecommand: ZMR00301 – Enable MIRO HK Generation

Parameters: PMRG0SID –Pad/SID  
                  PMRDSID1 –Pad  
                                  CMRV0001  
  1, default  
                  PMRDSID2 – SID  
                                  CMRV001  
  1, default

## 6.1.8.2 Disable MIRO HK Generation Telecommand

### 6.1.8.2.1 Description

This telecommand stops the MIRO housekeeping packet transfer to the 'outbound fifo management task' for transmission to the SC.

### 6.1.8.2.2 Packet Definition

Data Element	Size (bits)	Value (binary)	Comment
Version Number	3	000	EID-A Mandatory
Type	1	1	EID-A Mandatory
Data Field Header Flag	1	1	EID-A Mandatory
Application Process ID	7	1000111	EID-A Specified, 71
Packet Category	4	1100	EID-A Specified, Private (science) = 12
Sequence Flags	2	11	EID-A Mandatory
Sequence Count	14	000 + 1 up counter	First 3 bits are zero indicating 'Ground' as the source. The remaining 11 bits are zero initially, and constitute a one-up Telecommand counter. A separate counter is used for each APID/Packet Category combination.
Packet Length	16	0000000000000111	This gets set to the size of the application data field (in bytes) + 5. In this case, 7.
PUS Version	3	000	EID-A Specified, Ground Sourced Telecommand
Checksum Flag	1	1	EID-A Mandatory
Ack	4	0001	EID-A Specified, Acknowledgement of Acceptance
Packet Type	8	11000000	EID-A Specified, Housekeeping Reporting=3
Packet Subtype	8	00000100	EID-A Optional, 6=Disable HK Report Generation
Pad	8	00000000	EID-A Mandatory
Application Data	16	Variable	PAD=1, Structure ID=1
Packet Error Control	16	Variable	Telecommand Packet Checksum

### 6.1.8.2.3 Parameters

PAD (PMRDSID1): default = 1

Structure ID (PMRDSID2): identifier of which HK report to be acted on =1 (MIRO has only one HK report)

### 6.1.8.2.4 Execution Description

#### 6.1.8.2.4.1 Action Taken

On receipt MIRO stops generation of the HK report. When HK telemetry generation is off the engineering collection task is still running and collecting engineering data. It packetizes the data too. The only effect that turning the HK generation off has is that the completed telemetry packets are dropped on the floor instead of being transferred to the 'outbound fifo management task' for

transmission to the SC. If engineering housekeeping data collection is interfering with the quality of science data, then disabling HK telemetry generation will not fix that problem. They will need to use the 'engineering HK cycle skip' command.

6.1.8.2.4.2 *Resulting Effect*

Generation of MIRO Housekeeping Data packets (YMR00001) is disabled.

**6.1.8.2.5 RSDB Inputs**

Telecommand: ZMR00302 – Disable MIRO HK Generation

Parameters: PMRG0SID –Pad/SID  
                  PMRDSID1 –Pad  
                                  CMRV0001  
  1, default  
                  PMRDSID2 – SID  
                                  CMRV001  
  1, default

## 6.1.8.3 Time Update Telecommand

### 6.1.8.3.1 Description

This telecommand sends the spacecraft time to MIRO.

### 6.1.8.3.2 Packet Definition

Data Element	Size (bits)	Value (binary)	Comment
Version Number	3	000	EID-A Mandatory
Type	1	1	EID-A Mandatory
Data Field Header Flag	1	1	EID-A Mandatory
Application Process ID	7	1000111	EID-A Specified, 71
Packet Category	4	1100	EID-A Specified, Private (science) = 12
Sequence Flags	2	11	EID-A Mandatory
Sequence Count	14	000 + 1 up counter	First 3 bits are zero indicating 'Ground' as the source. The remaining 11 bits are zero initially, and constitute a one-up Telecommand counter. A separate counter is used for each APID/Packet Category combination.
Packet Length	16	0000000000000111	This gets set to the size of the application data field (in bytes) + 5. In this case, 7.
PUS Version	3	000	EID-A Specified, Ground Sourced Telecommand
Checksum Flag	1	1	EID-A Mandatory
Ack	4	0001	EID-A Specified, Acknowledgement of Acceptance
Packet Type	8	11000000	EID-A Specified, Time Synchronization=9
Packet Subtype	8	00000100	EID-A Optional, 1=Accept Time Update Request
Pad	8	00000000	EID-A Mandatory
Application Data	48	Variable	SCET=CUC time
Packet Error Control	16	Variable	Telecommand Packet Checksum

### 6.1.8.3.3 Parameters

Time Value (PMRG0005) = CUC time, the time code format is 4 octets of unit seconds followed by two octets of fractional seconds

### 6.1.8.3.4 Execution Description

#### 6.1.8.3.4.1 Actions Taken

The spacecraft elapsed time presented in this packet is used to update the instrument time reference on receipt of the following broadcast pulse.

#### 6.1.8.3.4.2 Resulting Effects

MIRO time-stamps each telemetry packet. The time value is furnished to a resolution of 1/65536 sec. MIRO maintains telemetry time stamping to an accuracy of better than 100 msec.

#### 6.1.8.3.4.3 *Additional Information*

MIRO requires spacecraft time update once per hour. The MIRO software uses its internal real time clock (RTC) provided on the RAD6000 as the precision time source. The RTC is crystal driven and provides the accuracy required for the TM packet time stamping.

The interaction between the spacecraft provided time and the RTC works as follows. The MIRO software stores the spacecraft time internally upon receipt of the spacecraft time synch telecommand. When the follow-up TSY pulse is received the MIRO software resets the RTC time to zero. From that point forward the RTC will show the precise elapsed time since the spacecraft time was last received. All telemetry timestamps are calculated by adding the contents of the RTC registers to the last received spacecraft time to produce the current time.

MIRO software resynchs to the spacecraft time as often as the spacecraft sends out the time synch telecommand.

#### 6.1.8.3.5 **RSDB Inputs**

Telecommand: ZMR00901 – Time Update

Parameters: PMRG0005 –Time Value

#### 6.1.8.4 Connection Test Telecommand

##### 6.1.8.4.1 Description

The objective of this command is to determine if MIRO is “alive”. It tests the connection path from the spacecraft to the instrument.

##### 6.1.8.4.2 Packet Definition

Data Element	Size (bits)	Value (binary)	Comment
Version Number	3	000	EID-A Mandatory
Type	1	1	EID-A Mandatory
Data Field Header Flag	1	1	EID-A Mandatory
Application Process ID	7	1000111	EID-A Specified, 71
Packet Category	4	1100	EID-A Specified, Private (science) = 12
Sequence Flags	2	11	EID-A Mandatory
Sequence Count	14	000 + 1 up counter	First 3 bits are zero indicating 'Ground' as the source. The remaining 11 bits are zero initially, and constitute a one-up Telecommand counter. A separate counter is used for each APID/Packet Category combination.
Packet Length	16	000000000000111	This gets set to the size of the application data field (in bytes) + 5. In this case, 7.
PUS Version	3	000	EID-A Specified, Ground Sourced Telecommand
Checksum Flag	1	1	EID-A Mandatory
Ack	4	0001	EID-A Specified, Acknowledgement of Acceptance
Packet Type	8	11000000	EID-A Specified, Test service = 17
Packet Subtype	8	00000100	EID-A Optional, 1=Connection Test request
Pad	8	00000000	EID-A Mandatory
Application Data	0	Variable	none
Packet Error Control	16	Variable	Telecommand Packet Checksum

##### 6.1.8.4.3 Parameters

None.

##### 6.1.8.4.4 Execution Description

###### 6.1.8.4.4.1 Actions Taken

When MIRO receives this request, it responds by generating a Connection Test Report (YMR00009) within 4 seconds if the following was completed successfully after start-up.

1. Mirror driven to mechanical stop
2. Mirror moved to space
3. Time synch received or 60 seconds, whichever is first
4. Turned on engineering telemetry collection.



6.1.8.4.4.2 *Resulting Effects*

A connection test report is generated (YMR00009)

**6.1.8.4.5 RSDB Inputs**

Telecommand: ZMR01701 – Connection Test

## 6.1.8.5 Enable Science Telecommand

### 6.1.8.5.1 Description

This telecommand enables the output of science telemetry packets. Science telemetry packets are still generated as long as the instrument is in any mode other than engineering mode.

### 6.1.8.5.2 Packet Definition

Data Element	Size (bits)	Value (binary)	Comment
Version Number	3	000	EID-A Mandatory
Type	1	1	EID-A Mandatory
Data Field Header Flag	1	1	EID-A Mandatory
Application Process ID	7	1000111	EID-A Specified, 71
Packet Category	4	1100	EID-A Specified, Private (science) = 12
Sequence Flags	2	11	EID-A Mandatory
Sequence Count	14	000 + 1 up counter	First 3 bits are zero indicating 'Ground' as the source. The remaining 11 bits are zero initially, and constitute a one-up Telecommand counter. A separate counter is used for each APID/Packet Category combination.
Packet Length	16	0000000000000111	This gets set to the size of the application data field (in bytes) + 5. In this case, 7.
PUS Version	3	000	EID-A Specified, Ground Sourced Telecommand
Checksum Flag	1	1	EID-A Mandatory
Ack	4	0001	EID-A Specified, Acknowledgement of Acceptance
Packet Type	8	11000000	EID-A Specified, Science Data Transfer=20
Packet Subtype	8	00000100	EID-A Optional, 1=Enable Science Report Generation (RTU-link)
Pad	8	00000000	EID-A Mandatory
Application Data	16	Variable	Pad field (9 bits)=0, PID (7bits=71)
Packet Error Control	16	Variable	Telecommand Packet Checksum

### 6.1.8.5.3 Parameters

Process ID (PMRG0PID): Pad field (9bits)=0, PID (7 bits)=71(default) – the science report on which the operation acts is defined by the PID of the TM source application. For all MIRO science reports the PAD=0 and the PID=71.

### 6.1.8.5.4 Execution Description

#### 6.1.8.5.4.1 Actions Taken

On receipt of this request, MIRO enables the outputting of science reports on the RTU link.

6.1.8.5.4.2 *Resulting Effects*

The transmission of Science telemetry (YMR00011) to the spacecraft is enabled.

**6.1.8.5.5 RSDB Inputs**

Telecommand: ZMR02001 – Enable Science

Parameters: PMRG0PID –Process ID

**6.1.8.6 Disable Science Telecommand****6.1.8.6.1 Description**

This telecommand disables the outputting of science telemetry packets to the spacecraft. Science telemetry packets are still generated as long as the instrument is in any mode other than engineering mode.

**6.1.8.6.2 Packet Definition**

Data Element	Size (bits)	Value (binary)	Comment
Version Number	3	000	EID-A Mandatory
Type	1	1	EID-A Mandatory
Data Field Header Flag	1	1	EID-A Mandatory
Application Process ID	7	1000111	EID-A Specified, 71
Packet Category	4	1100	EID-A Specified, Private (science) = 12
Sequence Flags	2	11	EID-A Mandatory
Sequence Count	14	000 + 1 up counter	First 3 bits are zero indicating 'Ground' as the source. The remaining 11 bits are zero initially, and constitute a one-up Telecommand counter. A separate counter is used for each APID/Packet Category combination.
Packet Length	16	0000000000000111	This gets set to the size of the application data field (in bytes) + 5. In this case, 7.
PUS Version	3	000	EID-A Specified, Ground Sourced Telecommand
Checksum Flag	1	1	EID-A Mandatory
Ack	4	0001	EID-A Specified, Acknowledgement of Acceptance
Packet Type	8	11000000	EID-A Specified, Science Data Transfer=20
Packet Subtype	8	00000100	EID-A Optional, 2=Disable Science Report Generation (RTU-link)
Pad	8	00000000	EID-A Mandatory
Application Data	16	Variable	Pad field (9 bits)=0, PID (7bits=71)
Packet Error Control	16	Variable	Telecommand Packet Checksum

**6.1.8.6.3 Parameters**

Process ID (PMRG0PID): Pad field (9bits)=0, PID (7 bits)=71(default) – the science report on which the operation acts is defined by the PID of the TM source application. For all MIRO science reports the PAD=0 and the PID=71.

**6.1.8.6.4 Execution Description**

**6.1.8.6.4.1**     *Actions Taken*

On receipt of this request, MIRO stops outputting of science reports on the RTU link. When the output of these science telemetry packets is disabled, the outbound fifo manager task drops all queued packets of that type on the floor the next time that it runs. It runs at 10 Hz.

**6.1.8.6.4.2**     *Resulting Effects*

The transmission of Science telemetry (YMR00011) to the spacecraft is disabled.

**6.1.8.6.5**     **RSDB Inputs**

Telecommand: ZMR02002 – Disable Science

Parameters:     PMRG0PID –Process ID

## 6.1.8.7 Reset Telemetry Telecommand

### 6.1.8.7.1 Description

If the telemetry stream from MIRO appears to be corrupted the DMS may issue this command as part of a telemetry recovery procedure.

### 6.1.8.7.2 Packet Definition

Data Element	Size (bits)	Value (binary)	Comment
Version Number	3	000	EID-A Mandatory
Type	1	1	EID-A Mandatory
Data Field Header Flag	1	1	EID-A Mandatory
Application Process ID	7	1000111	EID-A Specified, 71
Packet Category	4	1100	EID-A Specified, Private (science) = 12
Sequence Flags	2	11	EID-A Mandatory
Sequence Count	14	000 + 1 up counter	First 3 bits are zero indicating 'Ground' as the source. The remaining 11 bits are zero initially, and constitute a one-up Telecommand counter. A separate counter is used for each APID/Packet Category combination.
Packet Length	16	000000000000111	This gets set to the size of the application data field (in bytes) + 5. In this case, 7.
PUS Version	3	000	EID-A Specified, Ground Sourced Telecommand
Checksum Flag	1	1	EID-A Mandatory
Ack	4	0001	EID-A Specified, Acknowledgement of Acceptance
Packet Type	8	11000000	EID-A Specified, Common Payload Telecommands = 255
Packet Subtype	8	00000100	EID-A Optional, 1=Reset Telemetry Output Buffer
Pad	8	00000000	EID-A Mandatory
Application Data	0	Variable	none
Packet Error Control	16	Variable	Telecommand Packet Checksum

### 6.1.8.7.3 Parameters

None

### 6.1.8.7.4 Execution Description

#### 6.1.8.7.4.1 Actions Taken

The telemetry buffer is cleared.

#### 6.1.8.7.4.2 Resulting Effects

The telemetry in the buffer is lost.

**6.1.8.7.5 RSDB Inputs**

Telecommand: ZMR25501 – Reset telemetry

## 7 DATA OPERATIONS HANDBOOK (TELEMETRY)

### 7.1 TELEMETRY

#### 7.1.1 INTRODUCTION

The MIRO telemetry is downloaded in packets. Each packet has associated with it a

1. Name
2. Header information including Packet Type and Subtype,
3. Format, and
4. Parameters.

The MIRO Telemetry Packets are given in the table below.

Packet Name	Type	Sub Type	Type Name	Subtype Name	RSDB Name
Accept Success	1	1	Telecommand Verification	Acceptance Success Report	YMRST001
Incomplete Packet	1	2	Telecommand Verification	Acceptance Failure Report	YMRST002
Incorrect Checksum	1	2	Telecommand Verification	Acceptance Failure Report	YMRST003
Incorrect APID	1	2	Telecommand Verification	Acceptance Failure Report	YMRST004
Invalid Command Code	1	2	Telecommand Verification	Acceptance Failure Report	YMRST005
MIRO Housekeeping Data	3	25	Housekeeping Data	Housekeeping Parameter Report	YMR00001
MIRO On	5	1	Event Reporting	Normal Progress Report	YMR00012
Asteroid Mode Started	5	1	Event Reporting	Normal Progress Report	YMR00013
Asteroid Mode Completed	5	1	Event Reporting	Normal Progress Report	YMR00014
Mirror Error Type 1	5	2	Event Reporting	Warning Anomalous Event Report	YMR00002
Mirror Error Type 2	5	2	Event Reporting	Warning Anomalous Event Report	YMR00003
Mirror Error Type 3	5	2	Event Reporting	Warning Anomalous Event Report	YMR00004
Mirror Error Type 4	5	3	Event Reporting	Ground Action Anomalous Event Report	YMR00005
Mirror Error Type 5	5	3	Event Reporting	Ground Action Anomalous Event Report	YMR00006
CTS Error	5	3	Event Reporting	Ground Action Anomalous Event Report	YMR00015
Memory Dump	6	6	Memory Management	Memory Dump Report	YMR00007
Memory Checksum	6	10	Memory Management	Memory Check Report	YMR00008
Connection Report	17	2	Test Service	Connection Test Report	YMR00009
Spectroscopic (CTS) Science	20	3	Science Data	Science Data Report	YMR00011



Packet Name	Type	Sub Type	Type Name	Subtype Name	RSDB Name
Submillimeter Continuum Science	20	3	Science Data	Science Data Report	YMR00011
Millimeter Continuum Science	20	3	Science Data	Science Data Report	YMR00011
Miscellaneous Science	20	3	Science Data	Science Data Report	YMR00011

## 7.1.2 HOUSEKEEPING DATA TELEMETRY

### 7.1.2.1 Description

The MIRO housekeeping data contains engineering data including temperatures, voltages, and currents.

The housekeeping data packets are generated whenever the instrument is turned on in any mode. It is nominally generated every 11.2 seconds. If the housekeeping skip command is executed, the generation time can be set to multiples of 11.2 sec.

### 7.1.2.2 Packet Definition

Data Element	RSDB Name	Size (bits)	Value (binary)	Comment
Version Number		3	000	EID-A Mandatory
Type		1	0	EID-A Mandatory
Data Field Header Flag		1	1	EID-A Mandatory
Application Process ID		7	1000111	EID-A Specified, 71
Packet Category		4	0100	EID-A Specified, Housekeeping = 4
Segmentation Flags	NMRDH141	2	11	EID-A Mandatory
Source Sequence Count	NMRDH142	14	1 up counter	Zero initially, A separate counter is used for each APID/Packet Category combination (I.e. science, housekeeping, memory dump, etc.)
Packet Length	NMRAH142	16	10001001	This gets set to the size of the source data field (in bytes) + 9. This is 137 bytes.
Time	NMRAH143	48	Varies	Defines the time that the acquisition of the data within the packet was initiated. 4 bytes of seconds followed by 2 bytes of fractional seconds.
PUS Version	NMRDH145	3	010	EID-A Specified, Non-science data
Checksum Flag	NMRDH146	1	0	EID-A Mandatory
Spare	NMRDH147	4	0000	EID-A Mandatory
Packet Type	NMRDH148	8	00000011	EID-A Specified, Table 2.8.2-1, Housekeeping Reporting = 3
Packet Subtype	NMRDH149	8	00011001	EID-A Specified, Housekeeping Parameter Report = 25
Pad	NMRDH140	8	00000000	EID-A Specified
Source Data		1024	128 bytes	Detailed definition on following page.

## Engineering Source Data Definition

Data Field #	RSDB Parameter Reference		Data Size (bits)		Function
1	NMRA0001		8		Pad
1	NMRA0001		8		SID, value = 1
2	NMRA0002		16		Operational Mode
3	NMRA0003		16		SUCR bits 0-15*
4	NMRA0004		16		SUCR bits 16-31*
5	NMRA0005		16		Address 100 bits 8-15 (in LSBs)*
6	NMRA0006		16		Mirror Location: 1=sky, 2=hot, 3=cold
7	NMRA0064		16		Reserved
8	NMRA0065		16		Reserved
Data Field #	RSDB Parameter Reference	EU Channel No.	Data Size (bits)	Signal Name	Function
9	NMRA0009	0	16	T_BRANCHA1	CTS Temp. Sensor 1 Branch A
10	NMRA0010	1	16	T_BRANCHA2	CTS Temp. Sensor 2 Branch A
11	NMRA0011	2	16	T_BRANCHB1	CTS Temp. Sensor 1 Branch B
12	NMRA0012	3	16	T_BRANCHB2	CTS Temp. Sensor 2 Branch B
13	NMRA0013	4	16	T_ANATRAY1	CTS Temp. Sensor 1 Ana. Tray
14	NMRA0014	5	16	T_ANATRAY2	CTS Temp. Sensor 2 Ana. Tray
15	NMRA0007	6	16	EU-TEMP	Electronics Unit Temperature
16	NMRA0008	7	16	ECAL-TEMP	Reference Temp (634 ohms)
17	NMRA0015	16	16	+5V-LO	+5V Voltage Monitor
18	NMRA0016	17	16	+12V-LO	+12V Voltage Monitor
19	NMRA0017	18	16	-12V-LO	-12V Voltage Monitor
20	NMRA0018	19	16	+3.3VLO	+3.3V Voltage Monitor
21	NMRA0020	20	16	+24V-LO	+24V Voltage Monitor
22	NMRA0019	21	16	+5VANA-LO	+5V Ana. Voltage Monitor
23	NMRA0021	22	16	+5VI-LO	+5V Current Monitor
24	NMRA0022	23	16	+12VI-LO	+12V Current Monitor
25	NMRA0023	24	16	-12VI-LO	-12V Current Monitor
26	NMRA0026	25	16	+24VANAI-LO	+24V Current Monitor
27	NMRA0024	26	16	+3.3VI-LO	+3.3V Current Monitor
28	NMRA0025	27	16	+5VANAI-LO	+5V Ana. Current Monitor
29	NMRA0027	28	16	TLM-HEATING	USO Temp Status
30	NMRA0028	29	16	TLM-RF	USO RF Power Status
31	NMRA0029	30	16	HVPG1	CTS PG1 Voltage
32	NMRA0030	31	16	HVPG2	CTS PG2 Voltage
Data Field #	RSDB Parameter Reference	SU Channel No.	Data Size (bits)	Signal Name	Function
33	NMRA0031	0	16	COLD-LOAD1	Cold Load Temperature # 1
34	NMRA0032	1	16	COLD-LOAD2	Cold Load Temperature # 2
35	NMRA0033	2	16	WARM-LOAD1	Warm Load Temperature #1
36	NMRA0034	3	16	O/B	Optical Bench Temperature
37	NMRA0035	4	16	TELESCOPE-1	Telescope # 1 Temperature
38	NMRA0036	5	16	TELESCOPE-2	Telescope # 2 Temperature
39	NMRA0037	6	16	PLL-T	Phase Lock Loop Temperature
40	NMRA0038	7	16	IFP-DET-T	smm IF Processor Detector Temperature
41	NMRA0039	8	16	IFP-AMP-T	smm IF Processor Amplifier Temperature

42	NMRA0040	9	16	SMM-LO-GUNN	smm Lo Gunn Temperature
43	NMRA0041	10	16	MM-LO-GUNN	mm Lo Gunn Temperature
44	NMRA0042	11	16	MOTOR	Mirror Motor Temperature
45	NMRA0043	12	16	SEN-EL	Sensor Electronics Temperature
46	NMRA0044	13	16	WARM-LOAD2	Warm Load Temperature # 2
47	NMRA0045	14	16	CAL-TEMP-LO	Reference Temperature (191 ohms)
48	NMRA0046	15	16	CAL-TEMP-HI	Reference Temperature (681 ohms)
49	NMRA0047	16	16	+5V-LO	+5v Voltage Monitor
50	NMRA0048	17	16	+12V-1-LO	+12v Voltage Monitor # 1
51	NMRA0050	18	16	+12V-2-LO	+12v Voltage Monitor # 2
52	NMRA0049	19	16	-12V-LO	-12v Voltage Monitor
53	NMRA0051	20	16	+5VI-LO	+5v Current Monitor
54	NMRA0052	21	16	+12VI-1-LO	+12v Current Monitor # 1
55	NMRA0054	22	16	+12VI-2-LO	+12v Current Monitor # 2
56	NMRA0053	23	16	-12VI-LO	-12v Current Monitor
57	NMRA0059	24	16	MM-GUNN-I	mm Gunn Current Status
58	NMR0061 (no data)	25	16	SMM-MULT	smm Multiplier Current Status
59	NMRA0055	26	16	SMM-PLL-ERR	Static Phase Error for smm PLL
60	NMRA0056	27	16	FS1-ERR	Phase Error for Freq Synthesizer # 1
61	NMRA0057	28	16	FS2-ERR	Phase Error for Freq Synthesizer # 2
62	NMR0058	29	16	FS3-ERR	Phase Error for Freq Synthesizer # 3
63	NMRA0060	30	16	SMM-PLL-GUNN-I	smm Gunn Current Status (Via PLL)
64	Reserved	31	16	Reserved	

\* See following tables for identification of bits

### Address Bit Assignments

ADDR Start	ADDR End	Bit No.	RSDB NMRA0005 BIT No.	Type	Function
0100	01FF	0*		Output	Select EMUX 0
0100	01FF	1*		Output	Select EMUX 1
0100	01FF	2*		Output	Select EMUX 2
0100	01FF	3*		Output	Select EMUX 3
0100	01FF	4*		Output	Select EMUX 4
0100	01FF	5*		Output	Send CMD REG Data to SU
0100	01FF	6*		Output	Enable motor stepping
0100	01FF	7		Output	Load enable (1=enable, 0=disable)
0100	01FF	8*	15	Output	+12V SPEC On (0=off, 1=on)
0100	01FF	9*	14	Output	+5V SPEC On (0=off, 1=on)
0100	01FF	10*	13	Output	+5V ANA SPEC On (0=off, 1=on)
0100	01FF	11*	12	Output	+3.3V SPEC On (0=off, 1=on)
0100	01FF	12*	11	Output	-12V SPEC On (comes on when +12V SPEC is On) (0=off, 1=on)
0100	01FF	13*	10	Output	+24V USO On (0=off, 1=on)
0100	01FF	14*	9	Output	CAL HTR On (0=off, 1=on)
0100	01FF	15*	8	Output	CTS Tri-state: 1=disable, 0=Enable**
0200	02FF	0*		Output	ST CONV EU (Initially HI, LO-HI to start)

ADDR Start	ADDR End	Bit No.	RSDB NMRA0005 BIT No.	Type	Function
0200	02FF	1*		Output	ST CONV SU (initially HI, LO-HI to start)
0200	02FF	2*		Output	ST Continuum period (Initially HI, LO-HI to start)
0200	02FF	3*		Output	Continuum select (0=5ms, 1=100 ms)
0200	02FF	4*		Output	Motor speed select (0=100Hz, 1=500 Hz)
0200	02FF	5*		Output	ST Acquisition of SU Status
0200	02FF	6*		Output	Reset SMD FIFO (Initially HI, LO-HI to reset)
0200	02FF	7*		Output	Reset Data FIFO (initially HI, LO-HI to reset)
0200	02FF	8-15		Output	Unassigned
0300	03ff	0-15		Input	SU Status Register Bits 33-48 (mm cont.)
0400	04FF	0-15		Input	SU Status Register Bits 49-64 (smm cont.)
0500	05FF	0-15		Input	SU Status Register Bits 1-16
0600	06FF	0-15		Input	SU Status Register Bits 17-32
0700	07FF	0-15		Output	SU Control Register Bits 1-16
0800	08FF	0-15		Output	SU Control Register Bits 17-32

\* Low edge triggers, H/W initiates it low, I will initiate it HI in S/W, to toggle I will go LO-HI

\*\*In FM S/W Code: Initially enabled, disabled after CTS powered on, enabled by turning off CTS power.

### Sensor Unit Control Register (SUCR) Bit Assignments

Bit #	RSDB TM	RSDB Bit No.	Name	Description
0	NMRA0003	15	Hskp_Mux0	Selects housekeeping channel
1	NMRA0003	14	Hskp_Mux1	Selects housekeeping channel
2	NMRA0003	13	Hskp_Mux2	Selects housekeeping channel
3	NMRA0003	12	Hskp_Mux3	Selects housekeeping channel
4	NMRA0003	11	Hskp_Mux4	Selects housekeeping channel
5	NMRA0003	10	Pwr_Contl_Non-5VSMM	Commands +5V, +/-12V on after -5V is commanded using smm cont. mode
6	NMRA0003	9	IFP_Contl1	Bit 0 of IFP Power Control
7	NMRA0003	8	IFP_Contl2	Bit 1 of IFP Power Control
8	NMRA0003	7	MM_LNA_On	Powers on MM LNA Bias (0=on, 1=off)
9	NMRA0003	6	SMM_LNA_On	Powers on SMM LNA Bias (0=on, 1=off)
10	NMRA0003	5	Pwr_Contl_Non-5VMM	Commands +5V, +/-12V on after -5V is commanded on using mm cont. mode
11	NMRA0003	4	Pwr_Contl_Non-5VSPEC	Commands +5V, +/-12V on after -5V is commanded on using SPEC mode.
12	NMRA0003	3	Loop Reset	Phase-lock Reset (0 locks, 1 unlocks)
13	NMRA0003	2	IFP_Contl3	Bit 2 of IFP Power Control
14	NMRA0003	1	IFP_Contl4	Bit 3 of IFP Power Control
15	NMRA0003	0	Not used	0
16	NMRA0004	15	Set_smm_GO0	Sets bit for voltage to smm Gunn Osc (LSB)
17	NMRA0004	14	Set_smm_GO1	Sets bit for voltage to smm Gunn Osc
18	NMRA0004	13	Set_smm_GO2	Sets bit for voltage to smm Gunn Osc

Bit #	RSDB TM	RSDB Bit No.	Name	Description
19	NMRA0004	12	Set_smm_GO3	Sets bit for voltage to smm Gunn Osc (MSB)
20	NMRA0004	11	Not used	0
21	NMRA0004	10	Not used	0
22	NMRA0004	9	Not used	0
23	NMRA0004	8	Not used	0
24	NMRA0004	7	Set_pwr_mode0	Sets -5V for smm cont. mode
25	NMRA0004	6	Set_pwr_mode1	Sets -5V for mm cont. mode
26	NMRA0004	5	Set_pwr_mode2	Sets -5V for spec. mode
27	NMRA0004	4	Load_freq	Loads the (3) frequency synthesizer chips (set and clear to load)
28	NMRA0004	3	Mirror_pwr_ON	Sets mirror power on (0=on, 1=off)
29	NMRA0004	2	Mirror_dir	Sets mirror direction to forward (0=forward, 1=backward)
30	NMRA0004	1	Set_Freq_V-	Sets smm frequency switched state (+/- 5MHz)
31	NMRA0004	0	Pin_Puller-On	Activate pin puller (set and clear to activate)

Note: This data moved into engineering HK packet when packet has been filled with data. Reflects settings at about 11.2 seconds after the packet time stamp.

**7.1.2.3 Expected Values**

The expected values given below were measured during the MIRO thermal Vacuum Tests conducted at JPL prior to integration of the instrument onto the Rosetta spacecraft. The first table contains housekeeping data for when the instrument was cold, -20C.

The second table contains housekeeping data with the instrument in different modes for when the instrument interface for the EU was 55C and SU 40 C.

Values measured when instrument was "Cold" (Interfaces at about -20°C)

Mode/Housekeeping Parameter	Eng	Eng - Cal Heat On	Eng - USO On	Eng - Warmed Up	Eng - Cal Heat Off	Eng - USO Off	MM Cont	SMM Cont	Dual Cont	Dual Cont - CTS Warm Up, Power Hi	Dual Cont - CTS Warm Up Power Lo	Dual Cont - CTS Warm Up Off	CTS/SMM	CTS/SMM - CTS Heater On, Power Lo	CTS/SMM-CTS Heater Power LO, finished	CTS/Dual
Spect T1 [C]	-5.78	-6.08	-6.31	-9.73	-9.90	-10.03	-10.40	-10.63	-10.86	-10.96	-9.93	-8.90	-9.27	-8.20	-0.17	-0.30
Spect T2 [C]	-5.62	-5.95	-6.19	-9.63	-9.79	-9.93	-10.32	-10.52	-10.75	-10.85	-9.36	-9.03	-9.30	-9.30	-0.68	-0.55
Spect T3 [C]	-5.65	-5.94	-6.18	-9.60	-9.77	-9.90	-10.30	-10.53	-10.73	-10.87	-9.77	-8.74	-9.20	-9.10	-0.01	-0.15
Spect T4 [C]	-5.69	-6.03	-6.26	-9.67	-9.84	-9.97	-10.37	-10.60	-10.80	-10.93	-9.47	-9.11	-9.34	-9.37	-0.78	-0.65
Spect T5 [C]	-20.82	-20.83	-20.82	-20.82	-20.82	-20.82	-20.82	-20.82	-20.82	-20.82	-20.82	-20.82	-20.82	-20.87	-20.83	-20.82
Spect T6 [C]	-16.56	-16.79	-16.99	-18.31	-18.31	-18.34	-18.41	-18.47	-18.54	-18.57	-18.31	-18.08	-17.55	-17.42	-14.94	-14.77
EU Temp [C]	-6.98	-7.15	-7.25	-6.19	-6.26	-6.32	-6.59	-6.82	-7.02	-7.15	-7.05	-6.95	-6.16	-5.86	-3.24	-3.14
Ecal Temp [DN]	2600	2601	2601	2601	2601	2599	2598	2599	2601	2600	2601	2602	2602	2600	2602	2602
+5V EU [V]	5.17	5.17	5.17	5.17	5.17	5.17	5.17	5.17	5.17	5.11	5.11	5.11	5.08	5.08	5.08	5.08
+12V EU [V]	12.58	12.58	12.58	12.58	12.58	12.58	12.58	12.58	12.59	11.97	12.21	13.09	13.20	12.29	13.06	12.82
-12V EU [V]	-12.57	-12.57	-12.57	-12.57	-12.58	-12.56	-12.56	-12.56	-12.57	-12.66	-12.65	-13.10	-13.22	-12.75	-13.14	-13.01

Mode/Housekeeping Parameter	Eng	Eng - Cal Heat On	Eng - USO On	Eng - Warmed Up	Eng - Cal Heat Off	Eng - USO Off	MM Cont	SMM Cont	Dual Cont	Dual Cont - CTS Warm Up, Power Hi	Dual Cont - CTS Warm Up Power Lo	Dual Cont - CTS Warm Up Off	CTS/ SMM	CTS/ SMM - CTS Heater On, Power Lo	CTS/ SMM-CTS Heater Power LO, finished	CTS/ Dual
+3.3V EU [V]	3.31	3.31	3.31	3.31	3.31	3.31	3.31	3.31	3.31	3.37	3.37	3.37	3.44	3.44	3.44	3.44
+24V EU [V]	23.37	25.12	23.66	24.58	24.21	24.21	23.38	23.39	23.39	26.11	26.11	26.11	23.75	23.75	24.14	24.14
+5V Ana EU [V]	5.22	5.21	5.21	5.21	5.21	5.21	5.22	5.22	5.22	5.10	5.10	5.10	5.10	5.10	5.10	5.10
+5V Curr EU [A]	0.54	0.54	0.54	0.56	0.54	0.54	0.54	0.54	0.55	1.46	1.47	1.47	2.08	2.06	2.07	2.08
+12V Curr EU [A]	0.06	0.06	0.06	0.06	0.06	0.06	0.06	0.06	0.06	0.51	0.31	0.07	0.07	0.31	0.10	0.14
-12V Curr EU [A]	0.06	0.06	0.06	0.06	0.06	0.06	0.06	0.06	0.06	0.07	0.07	0.07	0.07	0.07	0.07	0.07
+24V Curr EU [A]	0.02	0.05	0.45	0.09	0.17	0.17	0.02	0.02	0.02	0.02	0.02	0.02	0.38	0.38	0.17	0.17
+3.3V Curr Eu [A]	0.01	0.01	0.01	0.01	0.01	0.01	0.01	0.01	0.01	0.66	0.67	0.66	1.33	1.35	1.33	1.34
+5V Ana Curr EU [A]	0.00	0.00	0.00	0.00	0.00	0.00	0.00	0.00	0.00	0.42	0.42	0.42	0.43	0.43	0.43	0.43
TLM Heating [V]	0.01	0.01	1.35	0.78	0.97	0.97	0.01	0.01	0.01	0.01	0.01	0.01	1.30	1.30	0.97	0.97
TLM RF [V]	0.01	0.01	0.05	0.03	0.03	0.03	0.01	0.01	0.01	0.01	0.01	0.01	0.05	0.05	0.03	0.03
CTS V Ana 1 [V]	0.01	0.01	0.01	0.01	0.01	0.01	0.01	0.01	0.01	2.46	2.47	2.47	2.45	2.45	2.46	2.46
CTS V Ana 2 [V]	0.01	0.01	0.01	0.01	0.01	0.01	0.01	0.01	0.01	2.47	2.48	2.48	2.46	2.46	2.47	2.47
Cold Load 1 Temp [C]	-46.97	-47.12	-47.20	-47.50	-47.42	-47.35	-47.35	-47.42	-47.42	-47.42	-47.50	-47.50	-47.64	-47.64	-48.02	-48.10
Cold Load 2 Temp [C]	-46.50	-46.65	-46.73	-46.95	-46.95	-46.80	-46.88	-46.95	-46.95	-46.95	-46.95	-46.95	-47.17	-47.17	-47.55	-47.55
Warm Load 1 Temp [C]	6.38	6.45	8.17	20.24	20.16	19.26	16.94	15.65	14.54	14.01	13.41	12.96	11.54	11.17	7.38	6.98
Warm Load 2 Temp [C]	6.36	6.44	8.08	20.20	20.13	19.28	16.90	15.63	14.51	13.98	13.39	12.94	11.52	11.14	7.26	6.96
Telescope1 Temp [C]	16.27	16.27	16.20	15.82	15.82	15.75	15.75	15.75	15.67	15.67	15.67	15.67	15.59	15.59	15.37	15.29
Telescope2 Temp [C]	17.38	17.31	17.31	16.86	16.86	16.79	16.79	16.71	16.71	16.71	16.64	16.64	16.56	16.56	16.34	16.34
PLL Temp [C]	-16.23	-16.38	-16.53	-18.45	-18.53	-18.60	-18.75	-16.16	-14.09	-13.42	-12.90	-12.53	-11.50	-11.20	-8.38	-8.23
IFP Det Temp [C]	-19.54	-19.76	-19.99	-21.72	-21.72	-21.80	-21.80	-21.65	-21.50	-21.35	-21.27	-21.19	-20.67	-20.52	-19.16	-19.01
IFP Amp Temp [C]	-18.70	-18.92	-19.07	-20.84	-20.92	-20.92	-20.99	-20.84	-20.70	-20.62	-20.47	-20.40	-19.73	-19.59	-18.26	-18.11
SMM LO Gunn Temp [C]	-21.74	-21.81	-21.81	-21.89	-21.89	-21.89	-21.89	-20.02	-18.68	-18.08	-17.63	-17.18	-16.28	-16.13	-15.54	-15.69
MM LO Gunn Temp [C]	-21.07	-21.07	-21.07	-21.15	-21.15	-21.07	-19.87	-19.65	-18.20	-18.45	-17.92	-17.47	-18.15	-18.60	-20.32	-19.57
Motor Temp [C]	-19.89	-19.89	-19.89	-20.04	-20.04	-20.04	-17.13	-16.02	-15.20	-16.24	-16.99	-17.43	-15.79	-16.54	-18.33	-16.32
Sensor Elect. Temp [C]	-13.00	-13.14	-13.29	-15.16	-15.24	-15.31	-15.38	-15.38	-15.31	-15.24	-15.09	-15.01	-14.71	-14.56	-13.29	-13.14
Optical Bench Temp [C]	-20.05	-20.05	-20.05	-20.12	-20.12	-20.12	-20.05	-19.82	-19.38	-19.08	-18.85	-18.56	-18.03	-17.88	-18.18	-16.33
Cal Temp Low [DN]	491	491	491	492	491	491	491	491	492	492	492	491	491	491	492	491
Cal Temp High [DN]	3735	3734	3735	3735	3735	3735	3735	3735	3735	3735	3735	3735	3735	3735	3735	3735
+5V SBEU [V]	5.17	5.17	5.17	5.17	5.17	5.17	5.14	5.14	5.11	5.11	5.11	5.11	4.99	4.99	4.98	4.96
+12V-1 SBEU [V]	12.35	12.35	12.35	12.35	12.35	12.35	12.35	12.35	12.47	12.47	12.47	12.47	12.03	12.03	12.03	12.05
+12V-2 SBEU [V]	12.00	12.00	12.00	12.00	12.00	12.01	11.92	11.92	11.84	11.84	11.84	11.84	11.92	11.92	11.92	11.84
-12V SBEU [V]	-12.59	-12.59	-12.59	-12.59	-12.59	-12.59	-12.69	-12.64	-12.77	-12.77	-12.77	-12.77	-12.18	-12.18	-12.17	-12.19
+5V Curr SBEU [A]	0.12	0.12	0.12	0.12	0.12	0.12	0.30	0.29	0.46	0.46	0.46	0.46	1.14	1.14	1.14	1.29
+12V Curr1 SBEU [A]	0.04	0.04	0.04	0.04	0.04	0.04	0.04	0.04	0.04	0.04	0.04	0.04	0.45	0.45	0.45	0.45
+12V Curr2 SBEU [A]	0.01	0.01	0.01	0.01	0.01	0.01	0.32	0.37	0.68	0.68	0.68	0.68	0.37	0.37	0.37	0.68
-12V Curr SBEU [A]	0.08	0.08	0.08	0.08	0.08	0.08	0.09	0.13	0.14	0.14	0.14	0.14	0.17	0.16	0.16	0.17
MM Gunn Curr [mA]	0.00	0.00	0.00	0.00	0.00	0.00	148.6	0.00	148.7	148.9	148.9	149.0	0.00	0.00	0.00	148.6
SMM Mult Curr [mA]	0.00	0.00	0.00	0.00	0.00	0.00	0.00	0.00	0.00	0.00	0.00	0.00	0.00	0.00	0.00	0.00
SMM PLL ERR [V]	0.00	0.00	0.00	0.00	0.00	0.00	0.00	0.22	0.23	0.22	0.23	0.23	2.60	2.58	2.54	2.53
FS1 Err [V]	0.00	0.00	0.00	0.00	0.00	0.00	0.00	0.00	0.00	0.00	0.00	0.00	1.62	1.62	1.66	1.66
FS2 Err [V]	0.00	0.00	0.00	0.00	0.00	0.00	0.00	0.00	0.00	0.00	0.00	0.00	1.68	1.68	1.71	1.71
FS3 Err [V]	0.00	0.00	0.00	0.00	0.00	0.00	0.00	0.00	0.00	0.00	0.00	0.00	1.53	1.54	1.59	1.59
SMM PLL Gunn Curr [mA]	0.00	0.00	0.00	0.00	0.00	0.00	0.13	123.6	124.0	124.2	124.4	124.5	121.8	121.8	122.1	122.0

Values measured when instrument was "Hot" (EU interface at about 55°C, Optical Bench at about 40°C)

Mode/Housekeeping Parameter	Eng	Eng - Cal Heat On	Eng - USO On	Eng - Warmed Up	Eng - Cal Heat Off	Eng - USO Off	MM Cont	SMM Cont	Dual Cont	Dual Cont - CTS Warm Up, Power Hi	Dual Cont - CTS Warm Up Power Lo	Dual Cont - CTS Warm Up Off	CTS/SMM	CTS/SMM - CTS Heater On, Power Lo	CTS/SMM-CTS Heater Power LO, finished	CTS/ Dual
Spect T1 [C]	67.56	66.88	66.37	66.21	65.75	65.48	65.11	64.83	64.42	65.79	64.63	67.53	66.64		66.69	68.31
Spect T2 [C]	67.77	67.16	66.64	66.51	66.07	65.76	65.39	65.11	64.71	66.44	65.25	67.23	66.78		68.28	68.38
Spect T3 [C]	67.67	66.98	66.47	66.33	65.89	65.62	65.24	64.97	64.52	65.96	64.76	67.67	66.71		68.83	68.39
Spect T4 [C]	67.69	67.07	66.56	66.43	65.98	65.71	65.34	65.06	64.62	66.26	65.10	67.14	66.73		68.20	68.30
Spect T5 [C]										60.84	56.81	56.75	56.78			
Spect T6 [C]	55.15	54.41	53.73	53.83	53.19	53.29	52.74	52.58	52.17	52.34	52.13	52.68	53.63		54.41	54.98
EU Temp [C]	57.84	57.00	56.62	56.52	56.28	56.08	55.81	55.57	55.27	55.27	55.13	55.51	56.39		57.44	57.94
Ecal Temp [DN]	2625	2625	2625	2625	2624	2625	2625	2624	2624	2623	2623	2625	2626		2626	2626
+5V EU [V]	5.16	5.16	5.16	5.16	5.16	5.16	5.16	5.16	5.16	5.10	5.10	5.10	5.09		5.05	5.05
+12V EU [V]	12.43	12.44	12.44	12.43	12.44	12.43	12.44	12.44	12.46	12.46	12.03	11.80	12.96	13.09	12.96	12.77
-12V EU [V]	-12.34	-12.37	-12.35	-12.35	-12.35	-12.35	-12.38	-12.36	-12.37	-12.47	-12.56	-12.90	-13.04		-12.97	-12.87
+3.3V EU [V]	3.32	3.32	3.32	3.32	3.32	3.32	3.32	3.32	3.32	3.38	3.38	3.38	3.49		3.47	3.46
+24V EU [V]	23.03	24.87	23.56	24.28	24.83	23.03	23.03	23.02	23.02	25.79	25.79	25.81	24.76		24.76	24.76
+5V Ana EU [V]	5.22	5.21	5.21	5.21	5.21	5.22	5.22	5.22	5.22	5.07	5.07	5.07	5.07		5.07	5.07
+5V Curr EU [A]	0.51	0.51	0.51	0.54	0.51	0.51	0.53	0.52	0.54	1.49	1.48	1.48	2.09		2.12	2.10
+12V Curr EU [A]	0.06	0.06	0.06	0.06	0.06	0.06	0.06	0.06	0.06	0.32	0.52	0.07	0.08		0.09	0.13
-12V Curr EU [A]	0.06	0.06	0.06	0.06	0.06	0.06	0.06	0.06	0.06	0.06	0.06	0.07	0.07		0.07	0.07
+24V Curr EU [A]	0.02	0.05	0.28	0.10	0.06	0.02	0.02	0.02	0.02	0.02	0.02	0.02	0.06		0.06	0.06
+3.3V Curr EU [A]	0.02	0.02	0.02	0.02	0.02	0.02	0.02	0.02	0.02	0.55	0.55	0.54	1.27		1.27	1.26
+5V Ana Curr EU [A]	0.00	0.00	0.00	0.00	0.00	0.00	0.00	0.00	0.00	0.46	0.46	0.46	0.46		0.46	0.46
TLM Heating [V]	0.01	0.01	1.04	0.79	0.79	0.01	0.01	0.01	0.01	0.01	0.01	0.01	0.79		0.79	0.79
TLM RF [V]	0.01	0.01	0.03	0.02	0.02	0.01	0.01	0.01	0.01	0.01	0.01	0.01	0.02		0.02	0.02
CTS V Ana 1 [V]	0.01	0.01	0.01	0.01	0.01	0.01	0.01	0.01	0.01	2.54	2.54	2.54	2.48		2.48	2.48
CTS V Ana 2 [V]	0.01	0.01	0.01	0.01	0.01	0.01	0.01	0.01	0.01	2.54	2.54	2.54	2.48		2.48	2.48
Cold Load 1 Temp [C]	-29.48	-28.73	-28.43	-28.50	-29.03	-29.10	-28.95	-28.80	-29.18	-29.33	-29.40	-29.10	-28.65		-29.33	-30.00
Cold Load 2 Temp [C]	-28.97	-28.22	-27.92	-27.92	-28.45	-28.52	-28.37	-28.30	-28.67	-28.75	-28.82	-28.60	-28.15		-28.75	-29.42
Warm Load 1 Temp [C]	49.01	48.56	48.78	48.78	48.78	46.89	44.61	43.02	40.98	38.86	39.46	37.80	36.14		34.55	33.57
Warm Load 2 Temp [C]	48.93	48.47	48.70	48.70	48.70	46.81	44.54	42.95	40.91	38.79	39.47	37.81	36.15		34.57	33.51
Telescope1 Temp [C]	23.08	23.08	23.08	23.08	23.08	23.08	23.08	23.08	23.08	23.00	23.00	23.00	23.00		23.00	22.93
Telescope2 Temp [C]	23.66	23.66	23.74	23.66	23.74	23.66	23.74	23.66	23.66	23.68	23.66	23.66	23.66		23.59	23.59
PLL Temp [C]	56.46	54.72	53.97	53.74	53.29	52.99	52.76	53.74	57.14	58.20	57.97	58.43	58.96		59.79	60.32
IFP Det Temp [C]	55.84	55.15	54.76	54.69	54.38	54.22	54.15	54.22	54.30	54.46	54.38	54.53	54.92		55.30	55.69
IFP Amp Temp [C]	55.56	54.88	54.43	54.28	54.05	53.90	53.75	53.82	53.90	54.05	53.97	54.05	54.58		55.03	55.34
SMM LO Gunn Temp [C]	43.71	42.41	41.64	41.26	40.96	40.65	40.27	42.26	43.33	44.32	44.02	44.63	45.01		44.93	44.78
MM LO Gunn Temp [C]	45.88	44.80	44.11	43.81	43.50	43.27	44.04	43.81	44.04	45.50	45.19	45.80	44.19		42.73	43.58
Motor Temp [C]	45.14	44.76	44.30	44.07	43.77	43.54	44.84	44.84	45.37	43.54	43.92	43.16	44.23		43.01	44.15
Sensor Elect. Temp [C]	59.09	58.24	57.63	57.32	57.09	56.86	56.56	56.48	56.48	56.63	56.56	56.71	56.94		57.17	57.55
Optical Bench Temp [C]	45.22	44.31	43.70	43.39	43.09	42.86	42.55	42.55	42.78	43.16	43.09	43.39	43.54		43.32	43.16
Cal Temp Low [DN]	487.0	487.0	487.0	487.0	487.0	487.0	487.0	487.0	487.0	486.0	486.0	487.0	487.0		487.0	486.0
Cal Temp High [DN]	3730	3731	3731	3731	3731	3731	3731	3731	3731	3731	3731	3731	3731		3731	3731
+5V SBEU [V]	5.17	5.18	5.17	5.18	5.17	5.17	5.13	5.14	5.09	5.09	5.09	5.09	4.93		4.93	4.89
+12V-1 SBEU [V]	12.23	12.23	12.23	12.23	12.23	12.24	12.31	12.24	12.38	12.37	12.37	12.37	11.89		11.89	11.91
+12V-2 SBEU [V]	12.04	12.03	12.04	12.04	12.03	12.03	11.94	11.93	11.84	11.84	11.84	11.84	11.93		11.93	11.84
-12V SBEU [V]	-12.42	-12.43	-12.43	-12.43	-12.43	-12.43	-12.52	-12.48	-12.61	-12.61	-12.61	-12.61	-11.95		-11.94	-11.98
+5V Curr SBEU [A]	0.14	0.14	0.14	0.14	0.14	0.14	0.33	0.31	0.50	0.50	0.50	0.50	1.20		1.20	1.35
+12V Curr1 SBEU [A]	0.07	0.07	0.07	0.07	0.07	0.07	0.07	0.07	0.07	0.07	0.07	0.07	0.48		0.48	0.48
+12V Curr2 SBEU [A]	0.01	0.01	0.01	0.01	0.01	0.01	0.34	0.40	0.73	0.73	0.73	0.73	0.40		0.40	0.73
-12V Curr SBEU [A]	0.08	0.08	0.08	0.08	0.08	0.08	0.09	0.13	0.15	0.15	0.15	0.15	0.16		0.16	0.18
MM Gunn Curr [mA]	0.00	0.00	0.00	0.00	0.00	0.00	157.3	0.00	157.3	157.3	157.3	157.4	0.00		0.00	157.1
SMM Mult Curr [mA]	0.00	0.00	0.00	0.00	0.00	0.00	0.00	0.00	0.00	0.00	0.00	0.00	0.00		0.00	0.00

Mode/Housekeeping Parameter	Eng	Eng - Cal Heat On	Eng - USO On	Eng - Warmed Up	Eng - Cal Heat Off	Eng - USO Off	MM Cont	SMM Cont	Dual Cont	Dual Cont - CTS Warm Up, Power Hi	Dual Cont - CTS Warm Up Power Lo	Dual Cont- CTS Warm Up Off	CTS/ SMM	CTS/ SMM - CTS Heater On, Power Lo	CTS/ SMM-CTS Heater Power LO, finished	CTS/ Dual
SMM PLL ERR [V]	0.00	0.00	0.00	0.00	0.00	0.00	0.00	0.29	0.29	0.29	0.29	0.29	2.29		2.25	2.21
FS1 Err [V]	0.00	0.00	0.00	0.00	0.00	0.00	0.00	0.00	0.00	0.00	0.00	0.00	2.70		2.71	2.71
FS2 Err [V]	0.00	0.00	0.00	0.00	0.00	0.00	0.00	0.00	0.00	0.00	0.00	0.00	2.41		2.42	2.42
FS3 Err [V]	0.00	0.00	0.00	0.00	0.00	0.00	0.00	0.00	0.00	0.00	0.00	0.00	2.67		2.69	2.70
SMM PLL Gunn Curr [mA]	0.00	0.00	0.00	0.00	0.00	0.00	0.06	145.4	145.8	145.1	146.1	146.2	144.9		145.1	144.9





EU Temp [C]

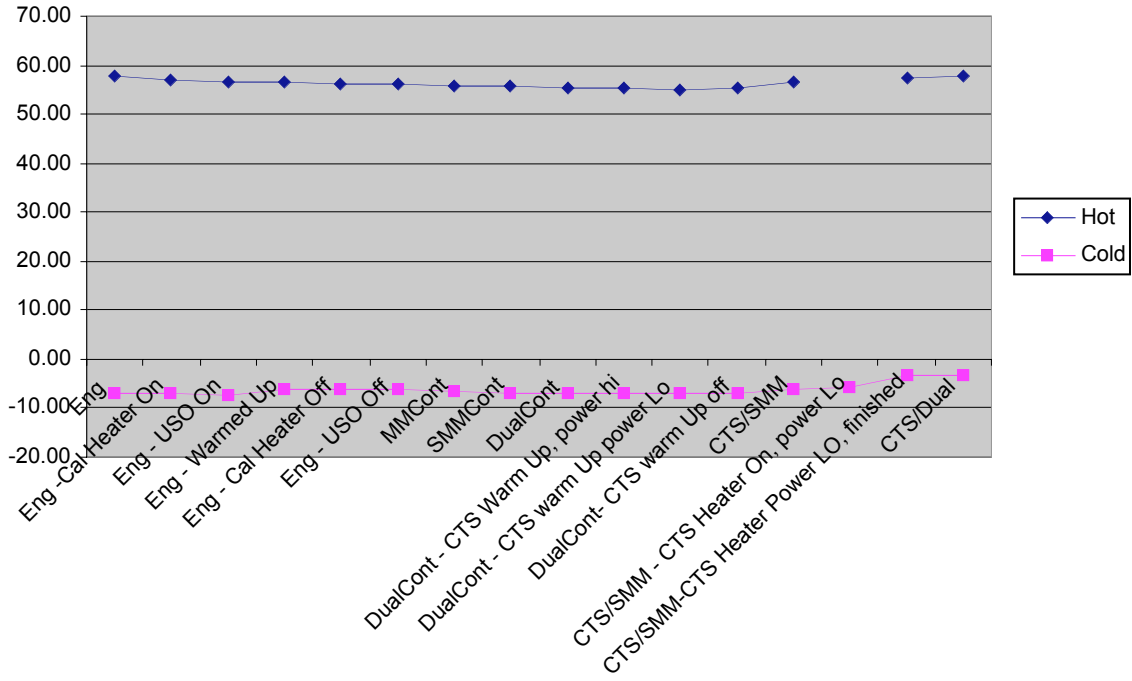

+5V EU [V]

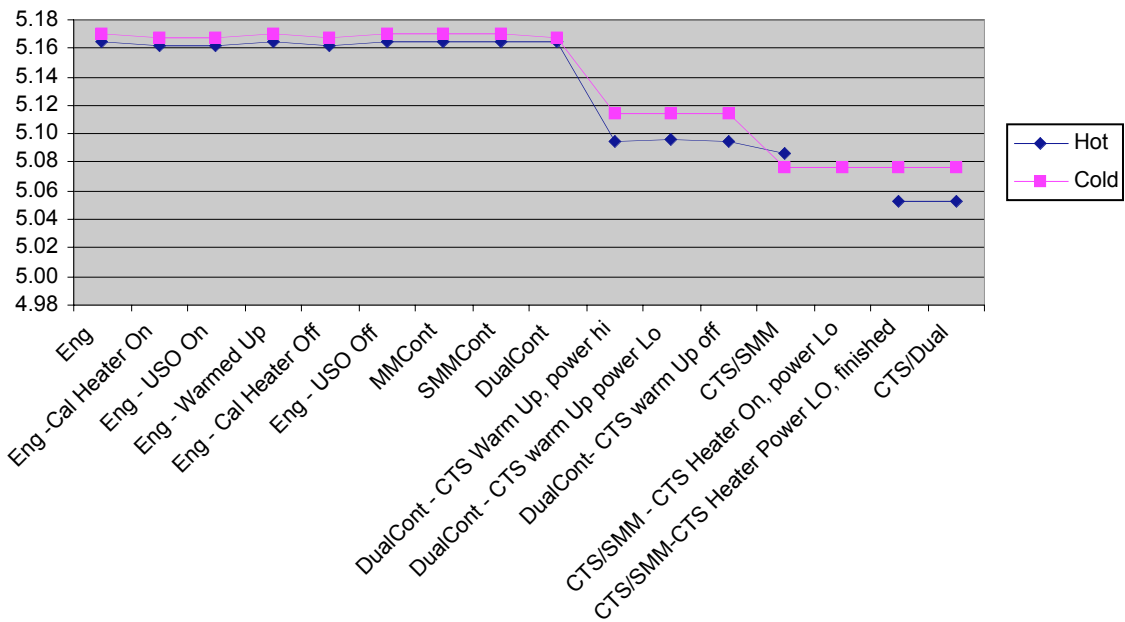

**+12V EU [V]**

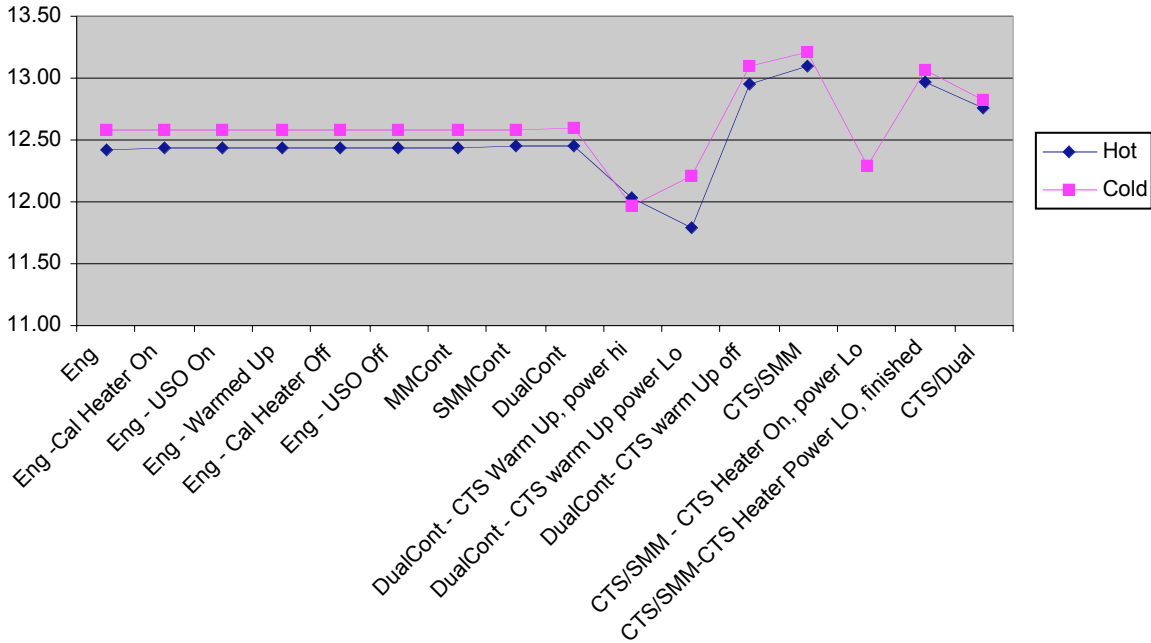

**-12V EU [V]**

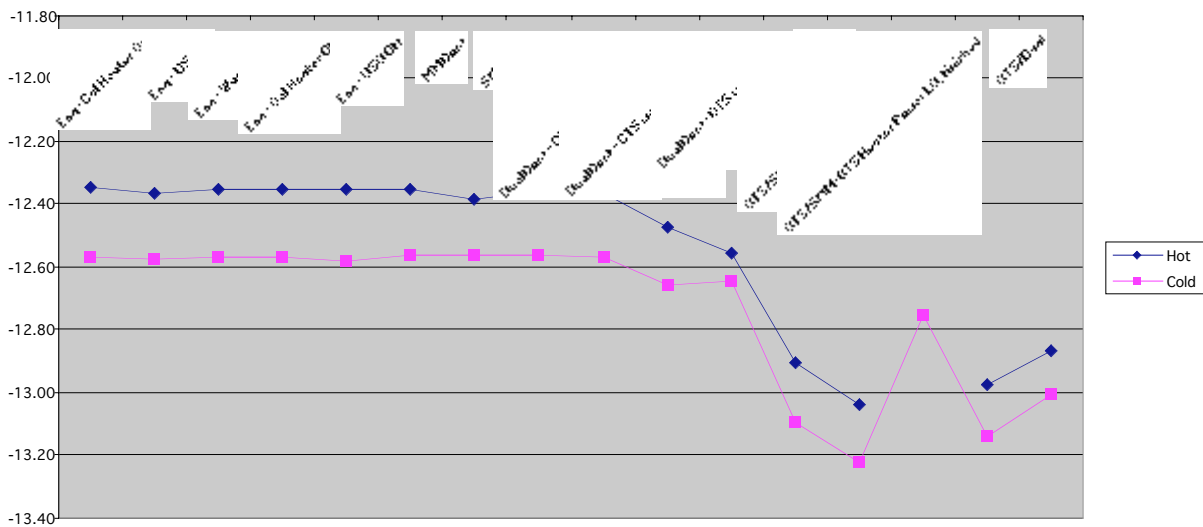

**3.3 V EU [V]**

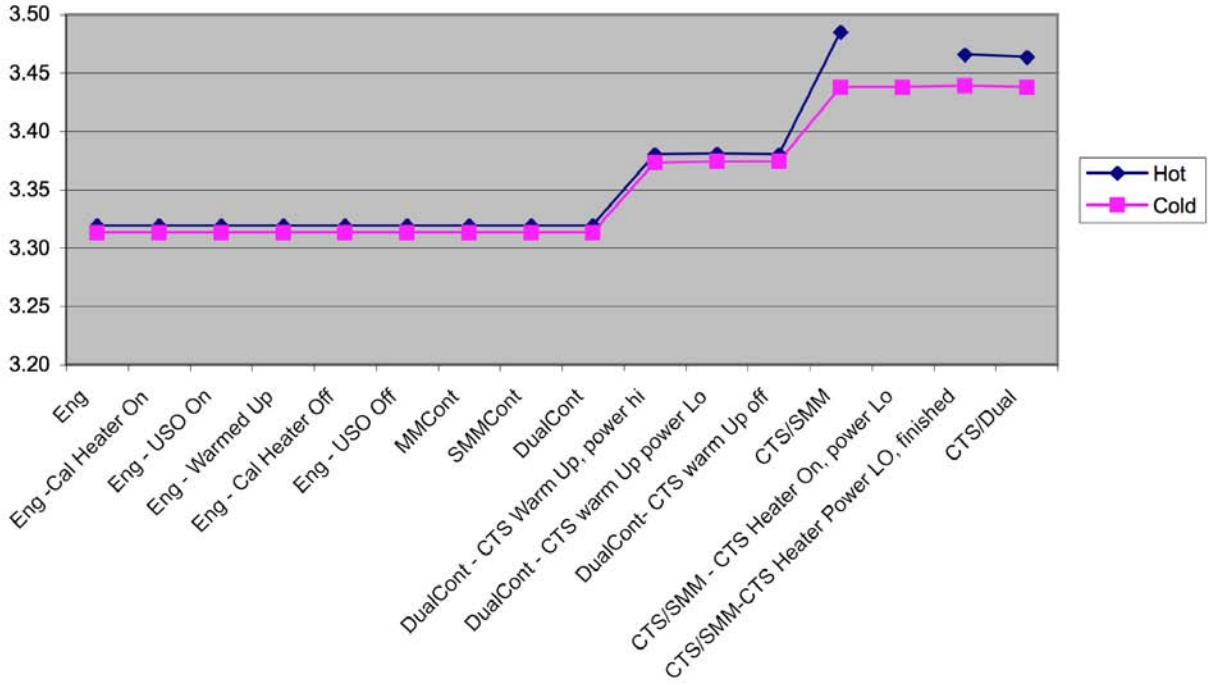

**24V EU**

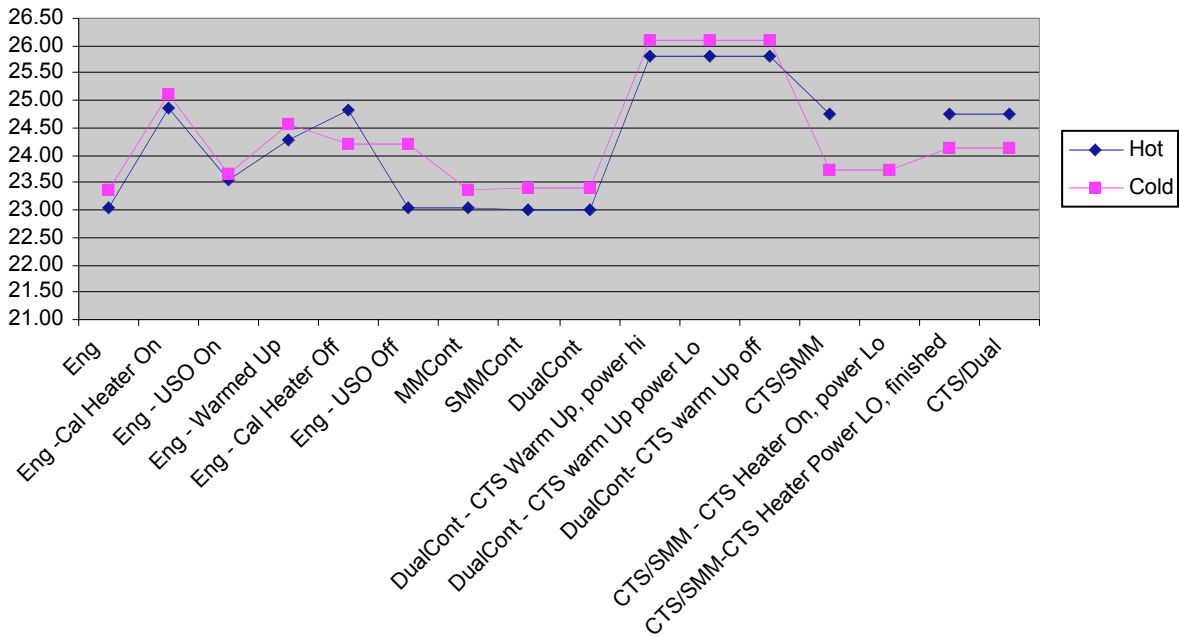

**+5V Ana EU [V]**

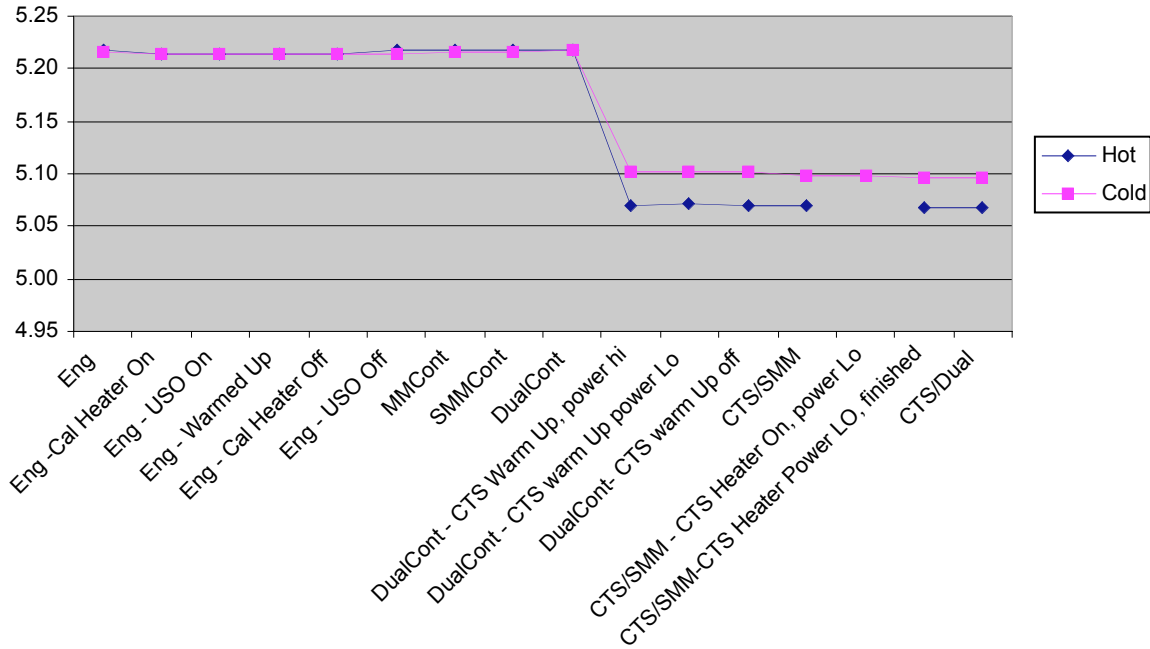

**5V Curr EU [A]**

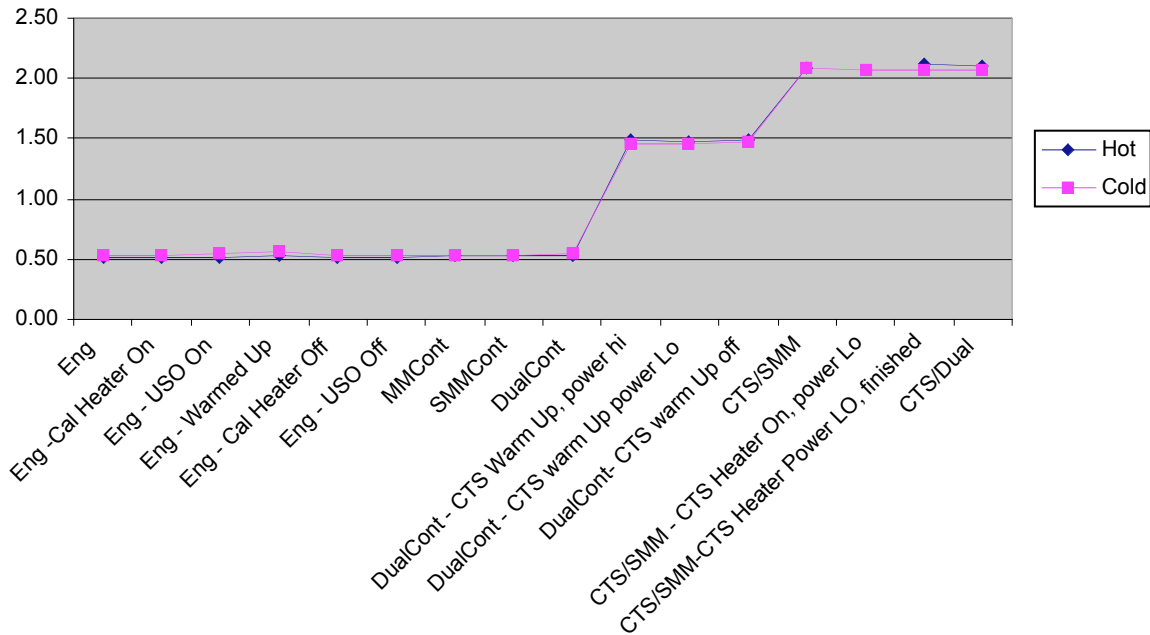

12V Current EU [A]

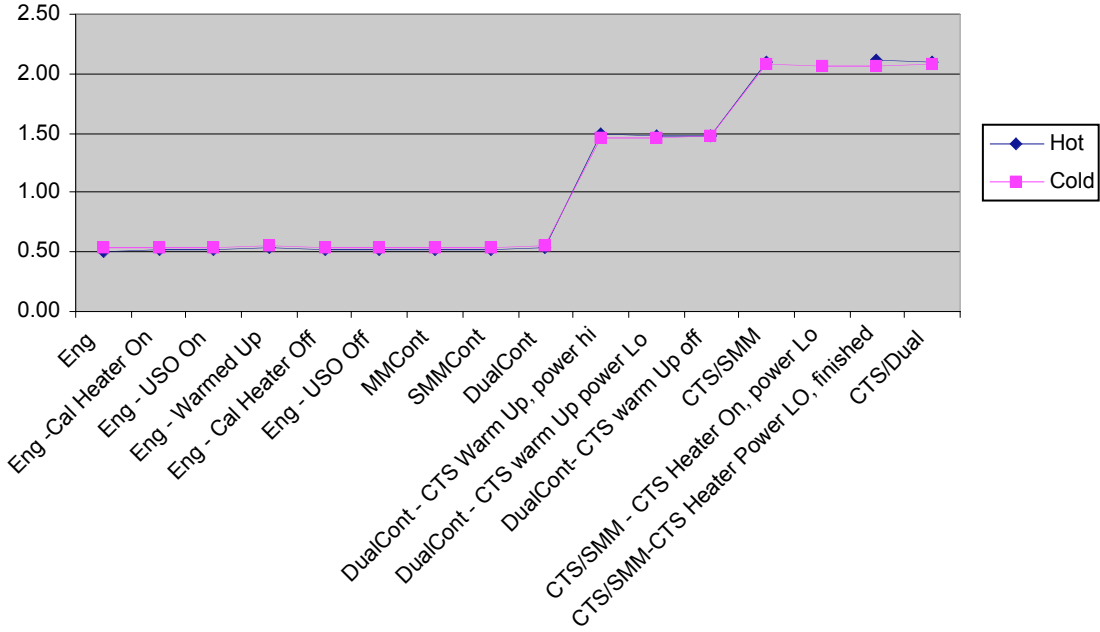

-12V Current EU [A]

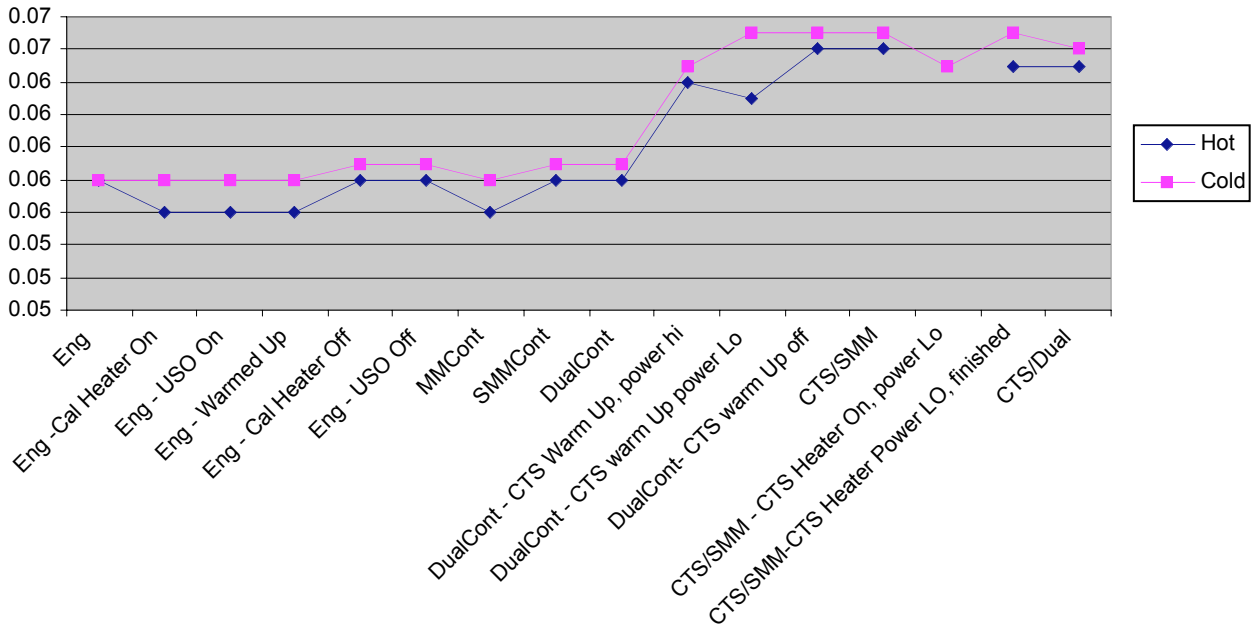

24V Current EU [A]

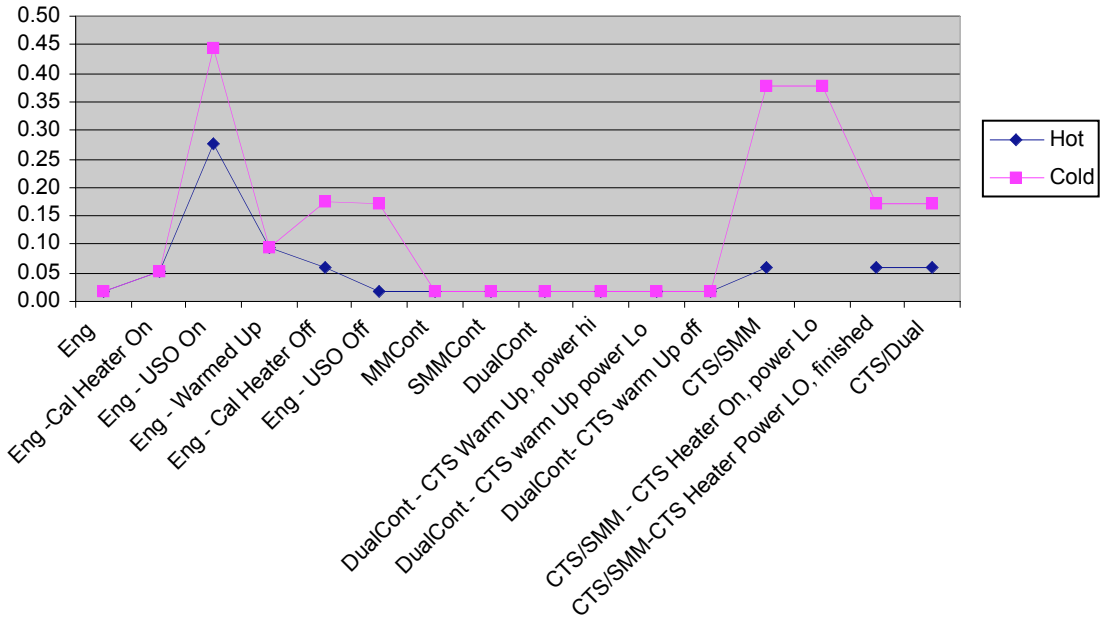

3.3V Current EU

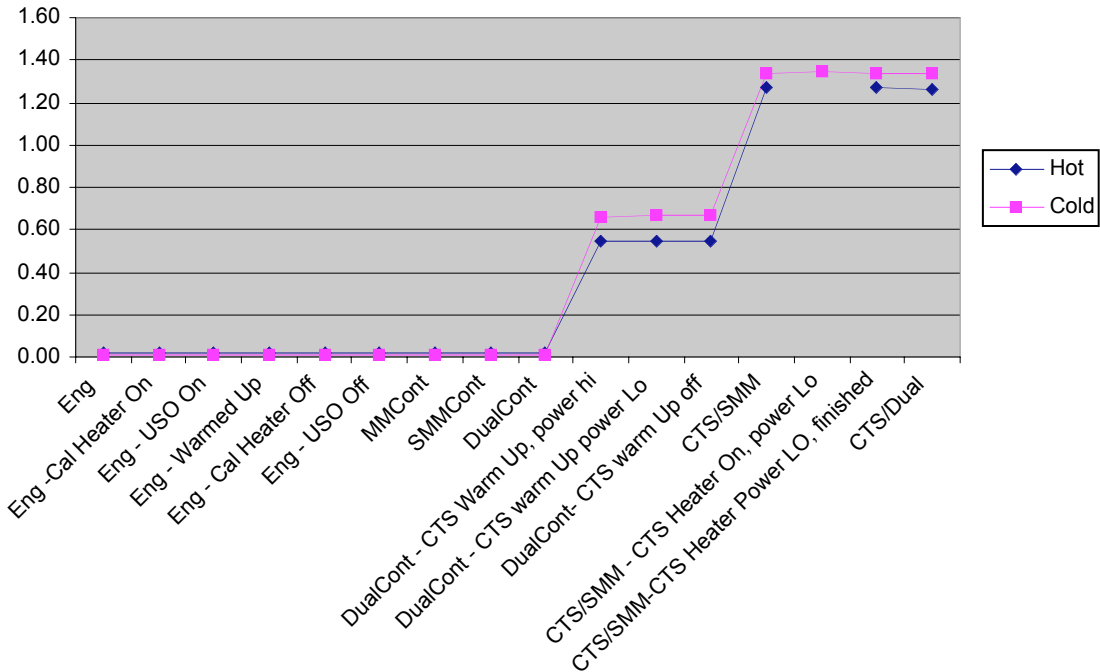

**5V Ana Current EU**

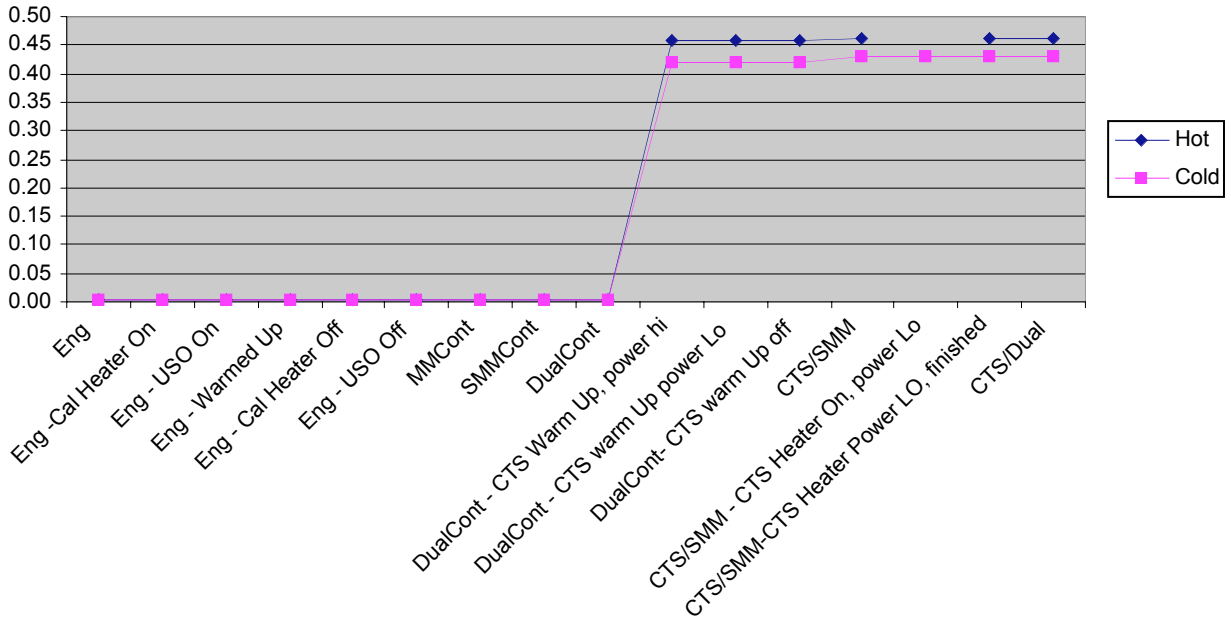

**TLM Heating**

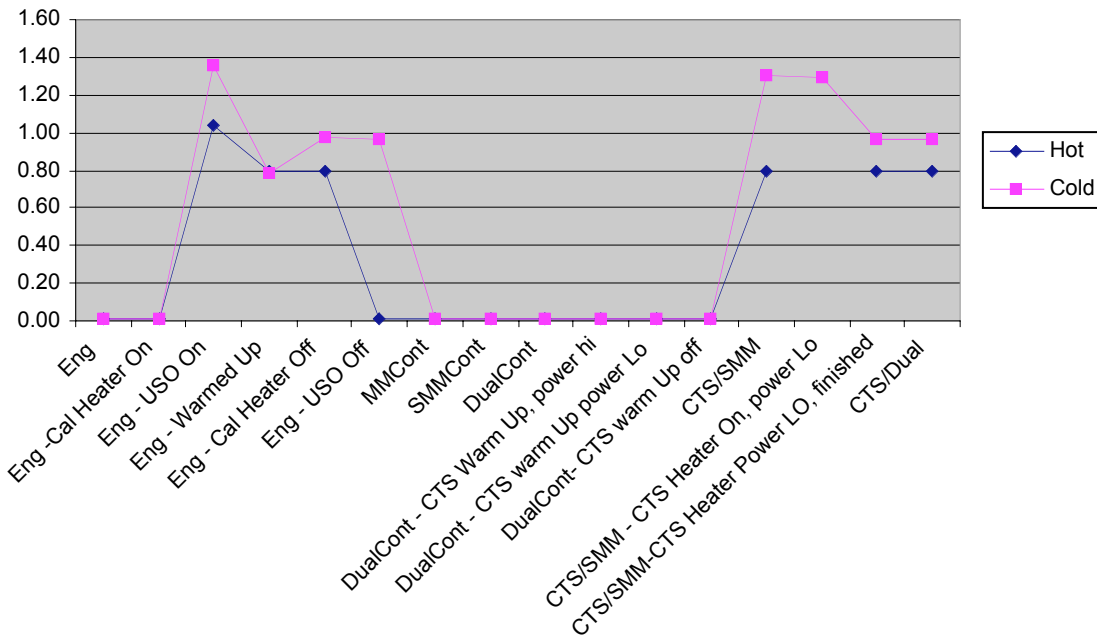



**TLM RF**

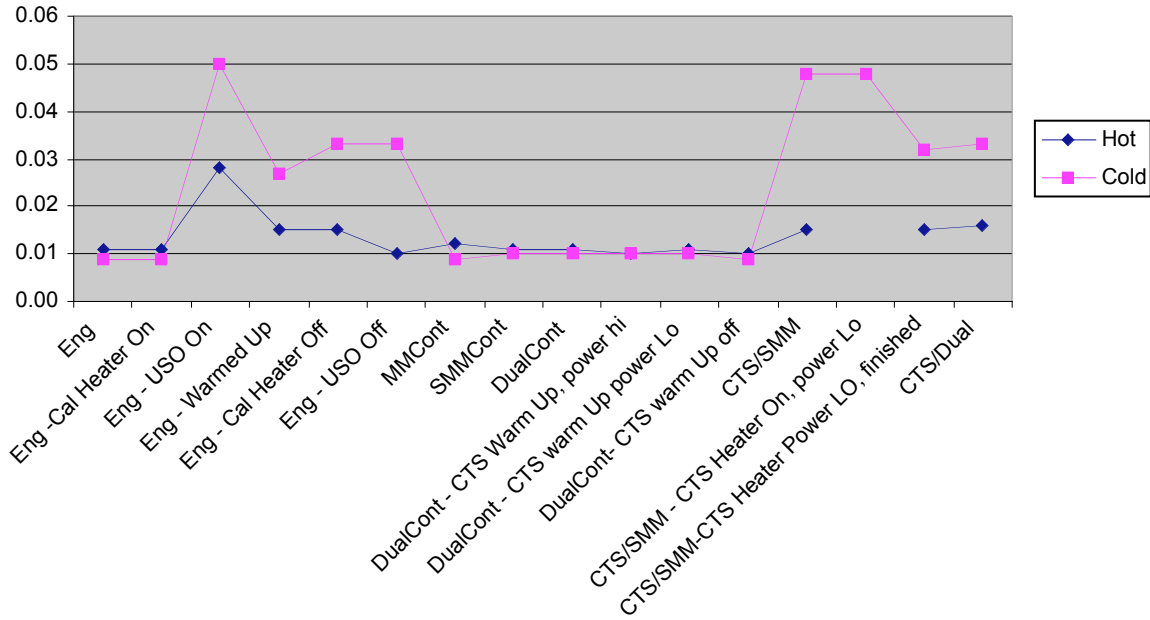

**CTS V Ana1 [V]**

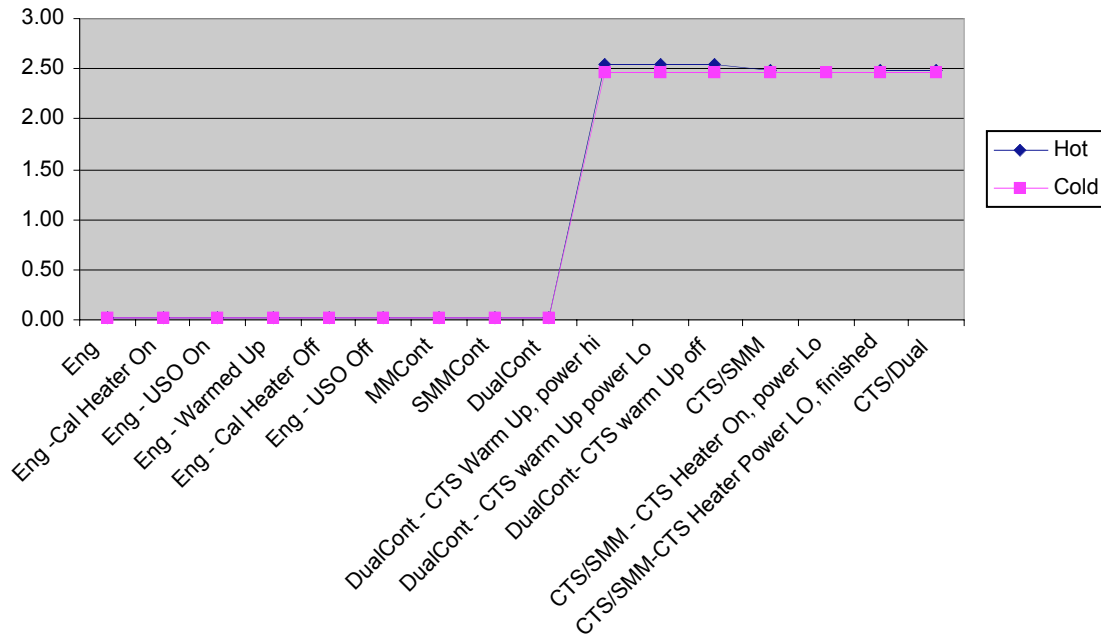

CTS V Ana 2 [V]

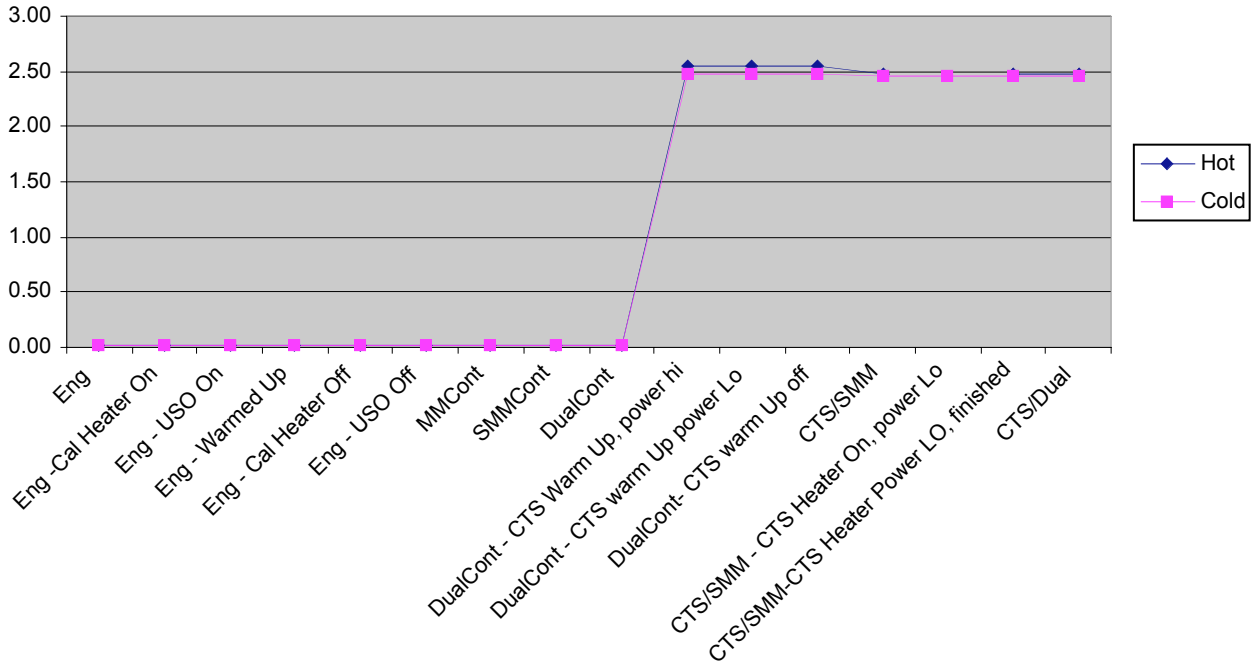

PLL Temp

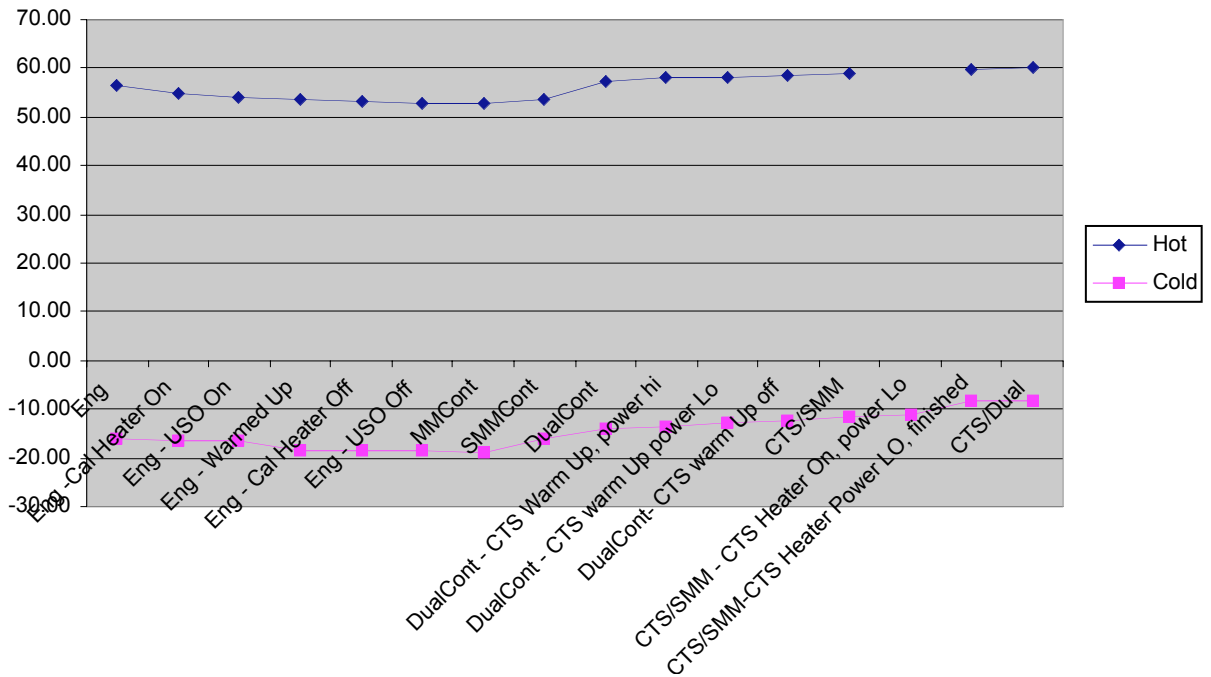

**IFP Det Temp**

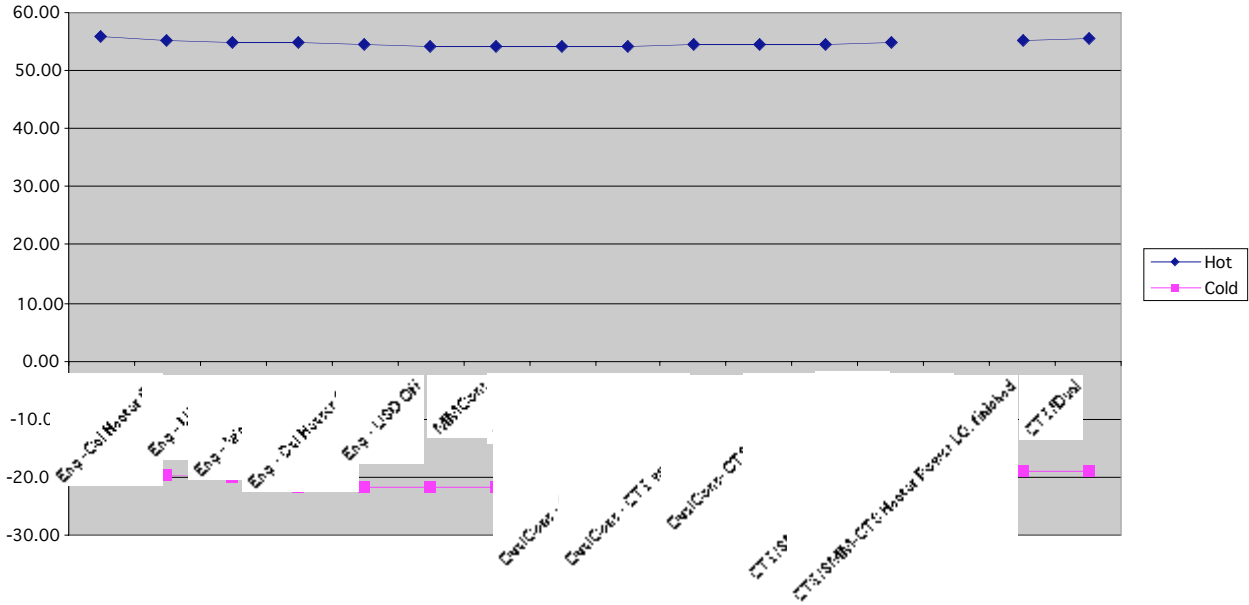

**IFP Amp Temp**

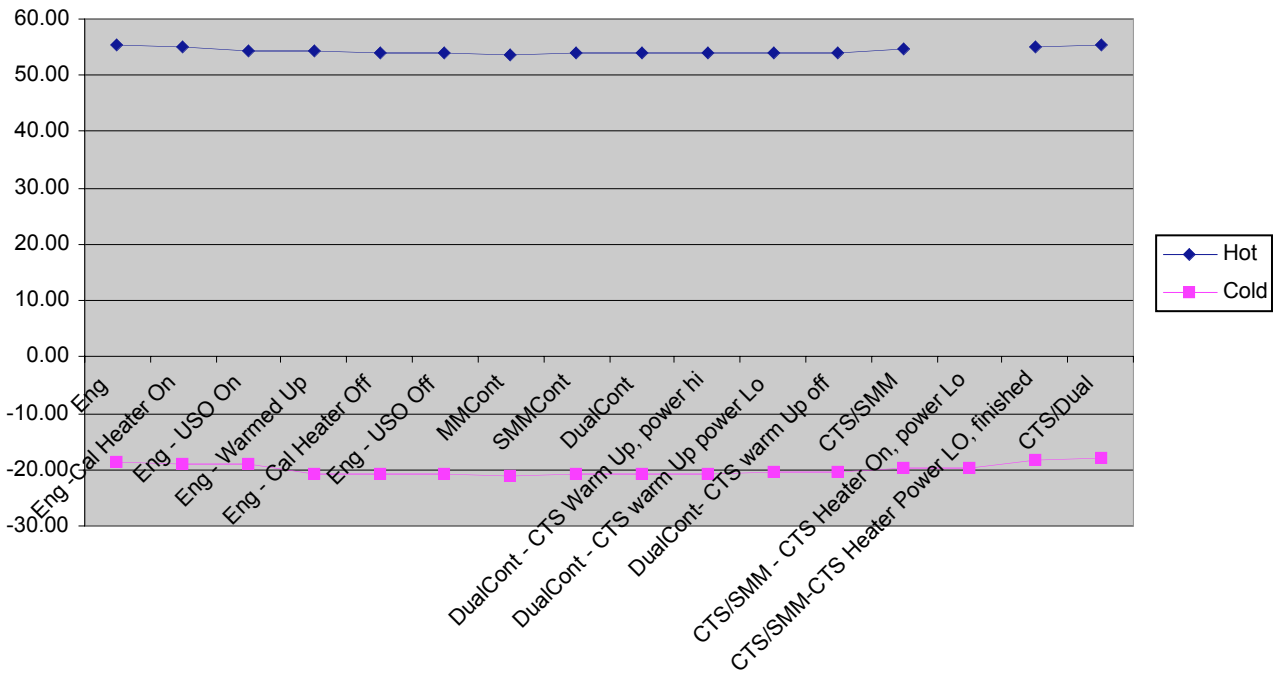

**SMM Gunn Temp**

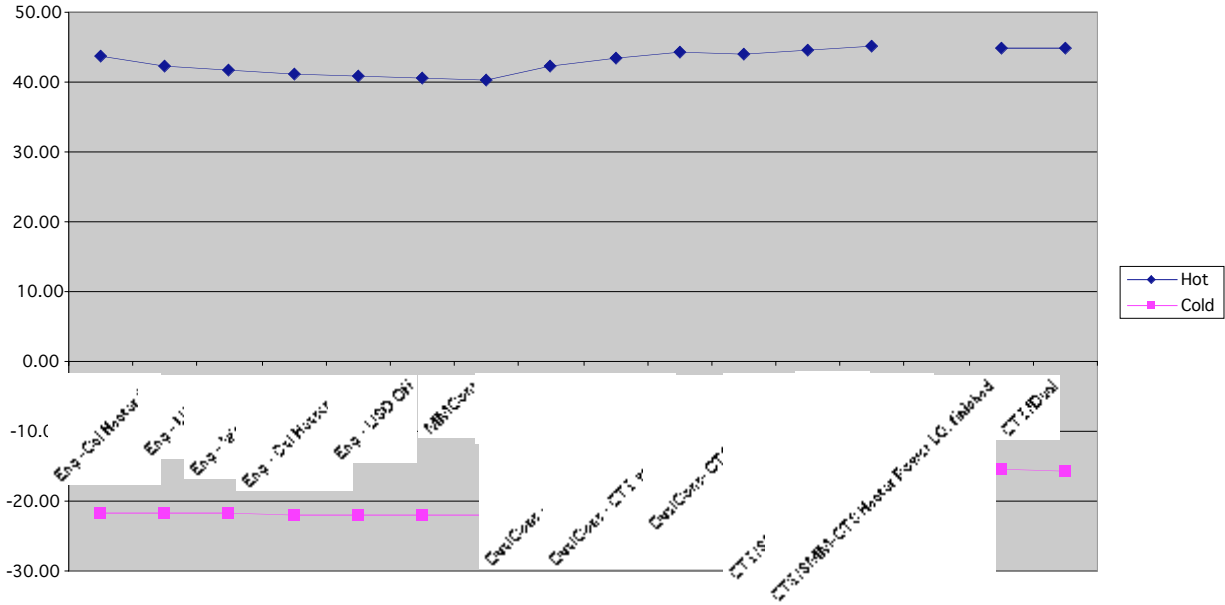

**MM Gunn Temp**

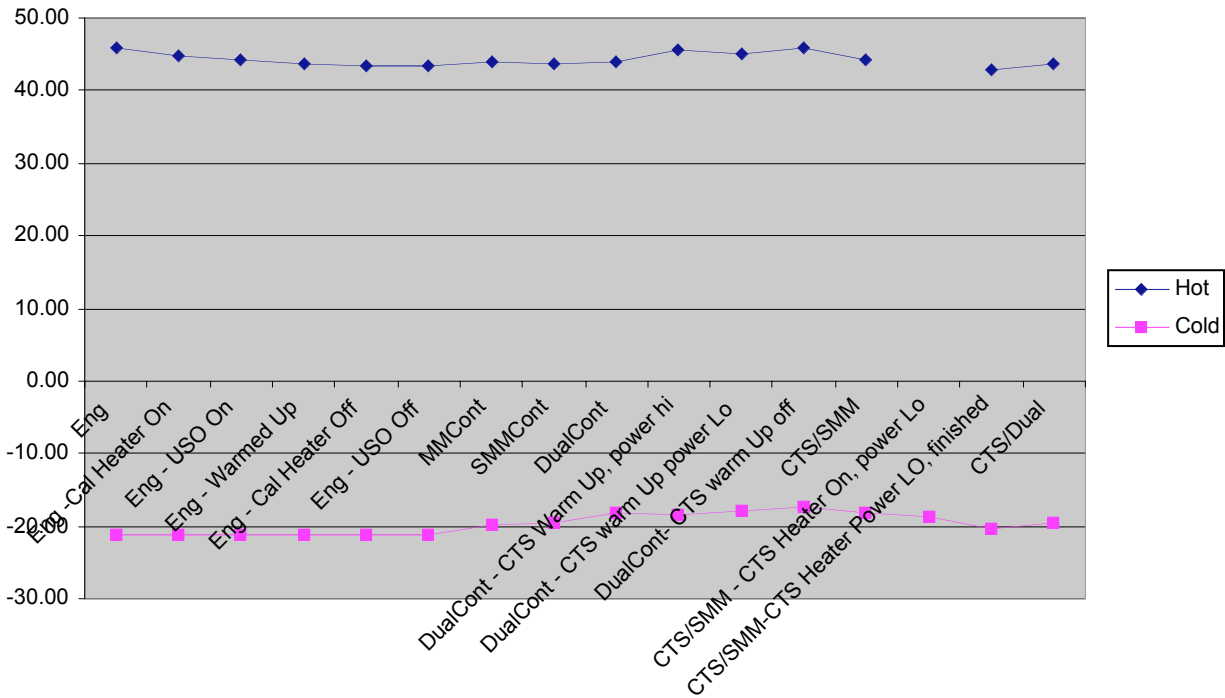

**Cal Motor Tem**

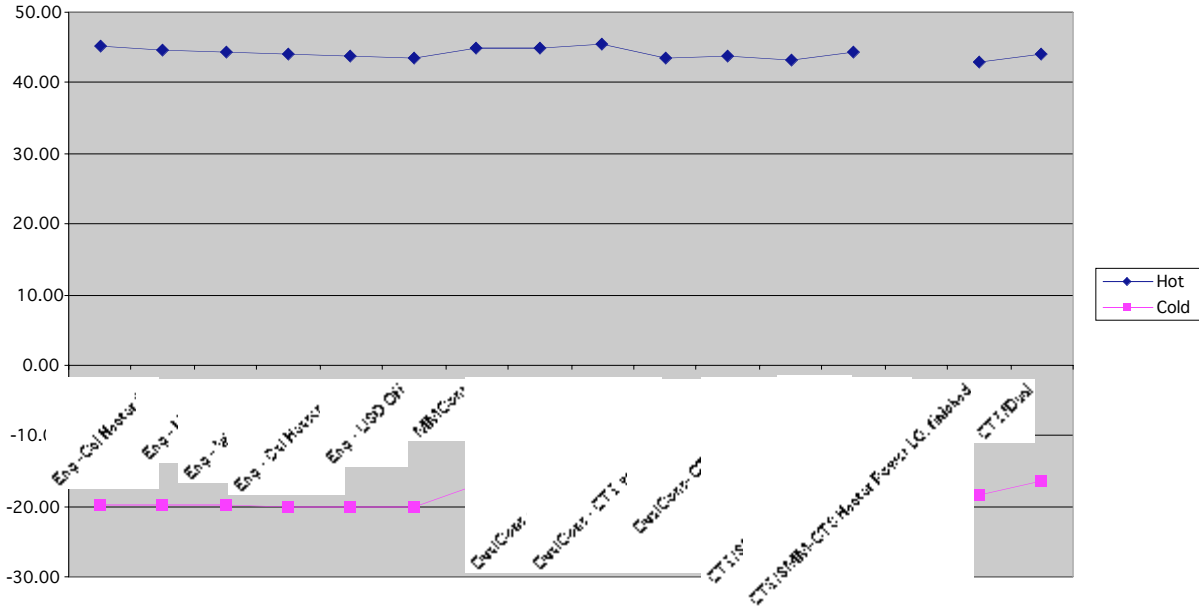

**Sensor Electronics Temp**

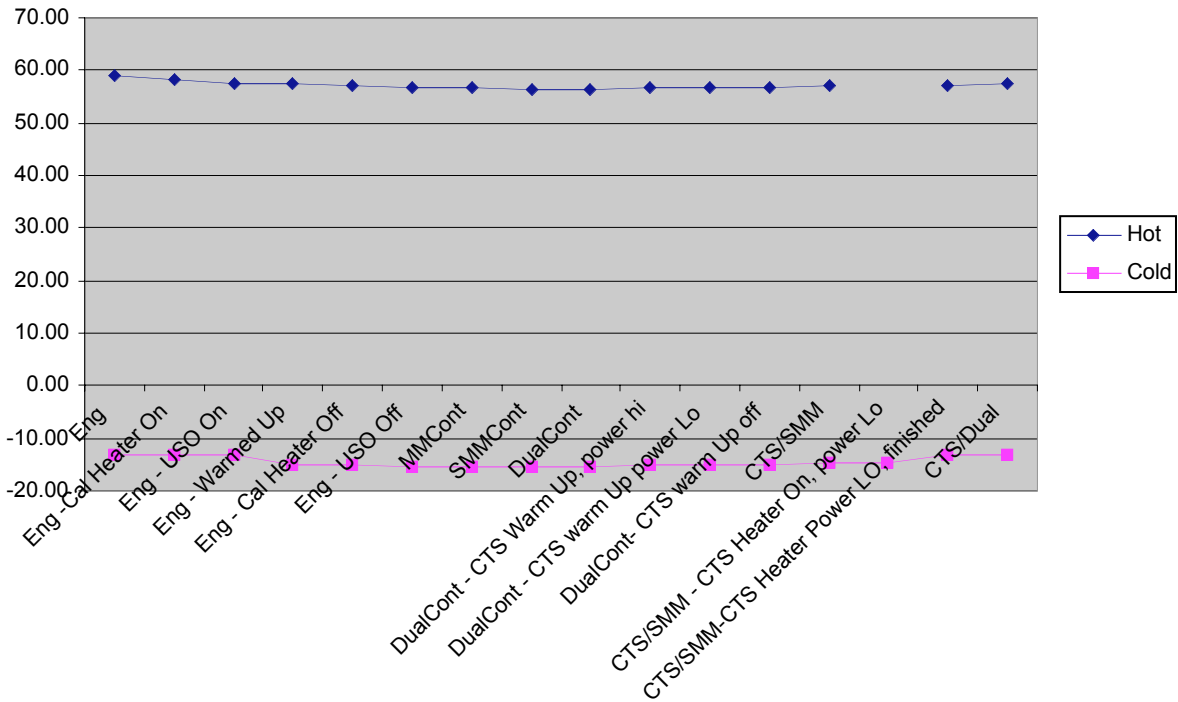

**Optical Bench Temp**

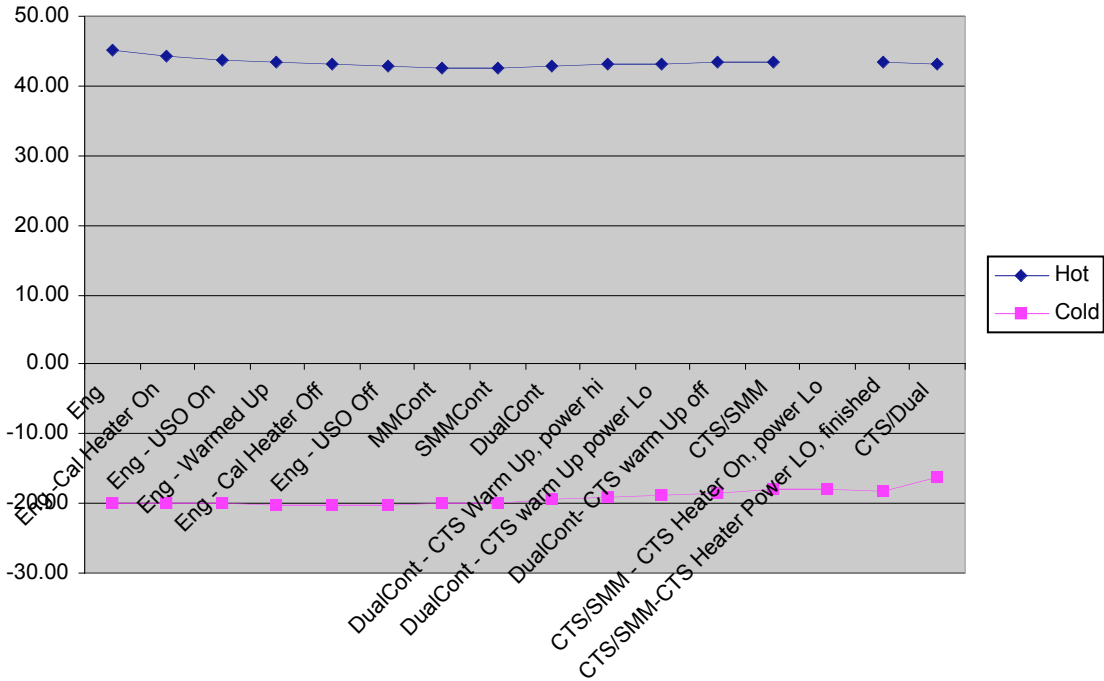

**5V SBEU [V]**

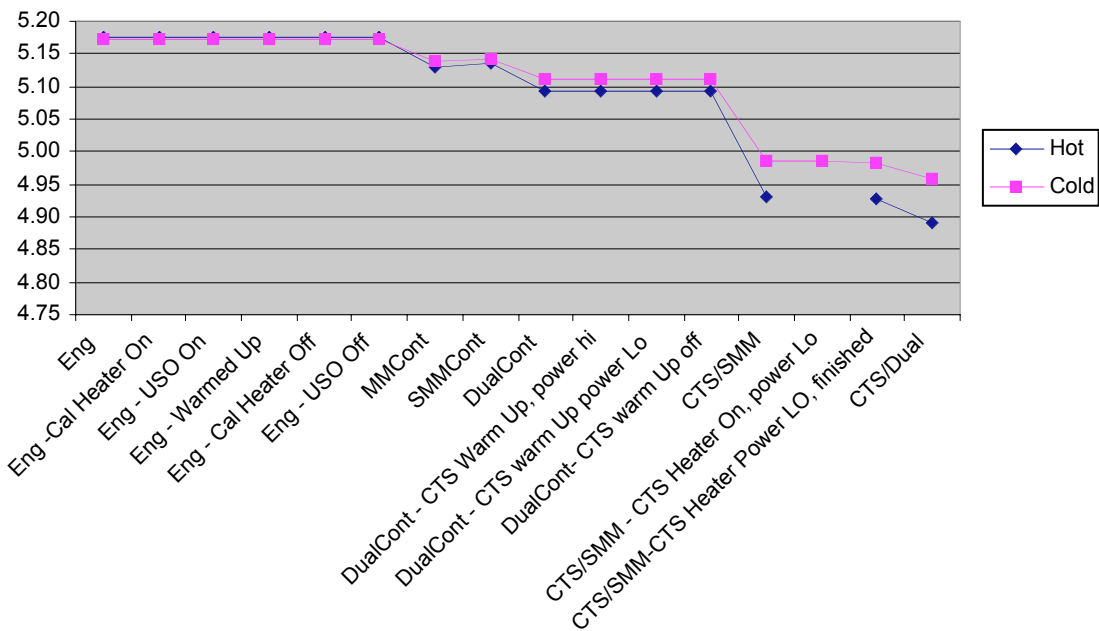

**12V-1 SBEU [V]**

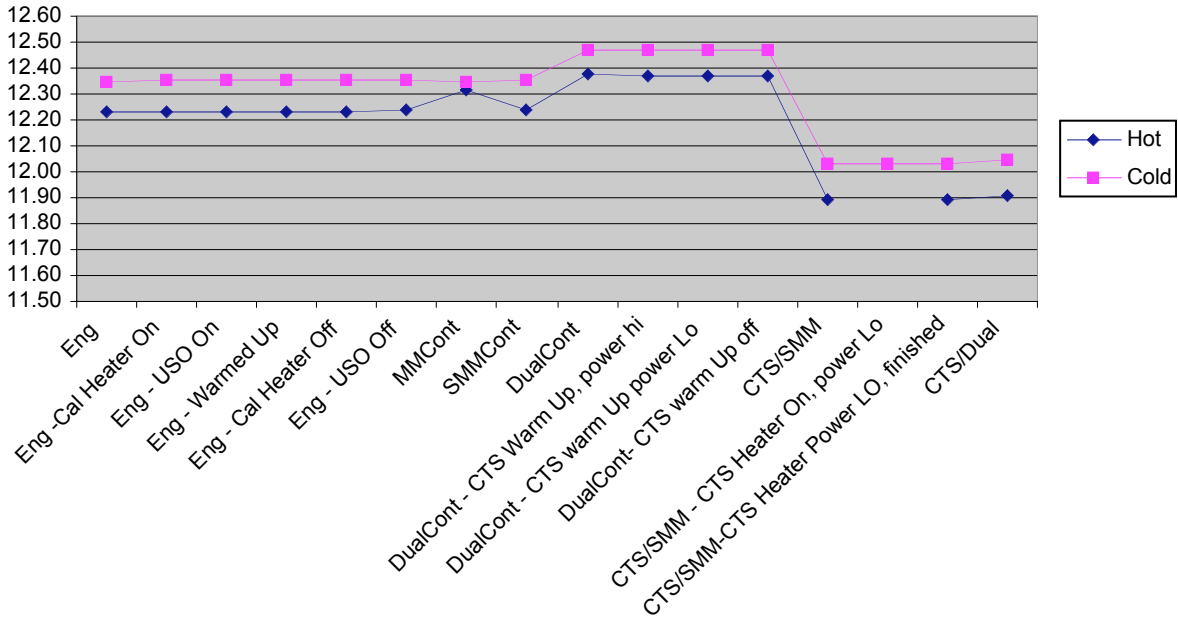

**12 V-2 SBEU [V]**

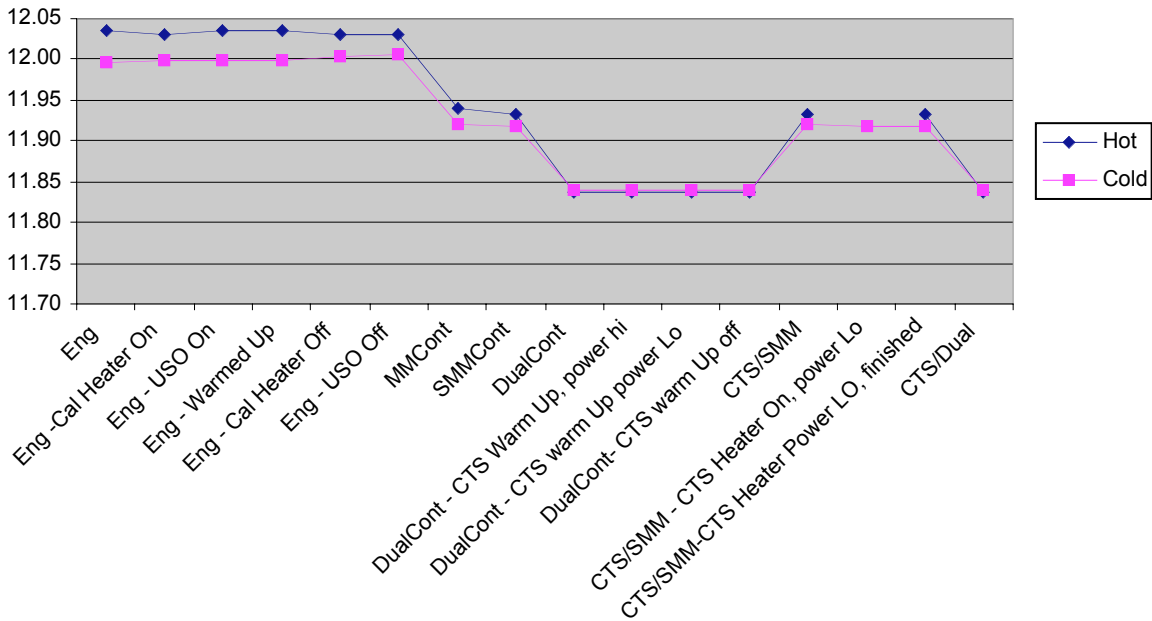

-12V Sbeu

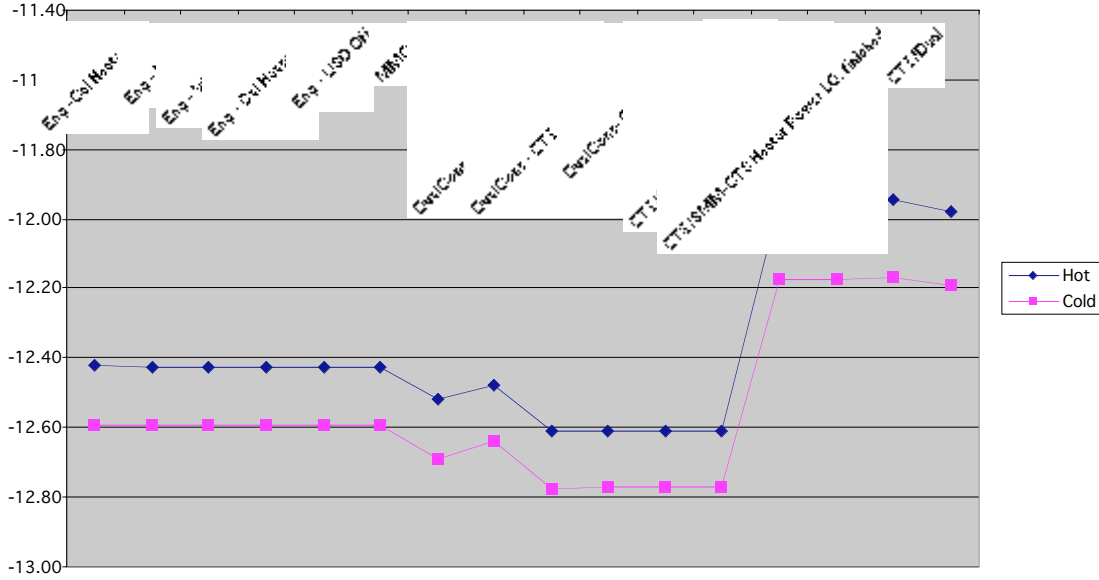

5V Current SBEU [A]

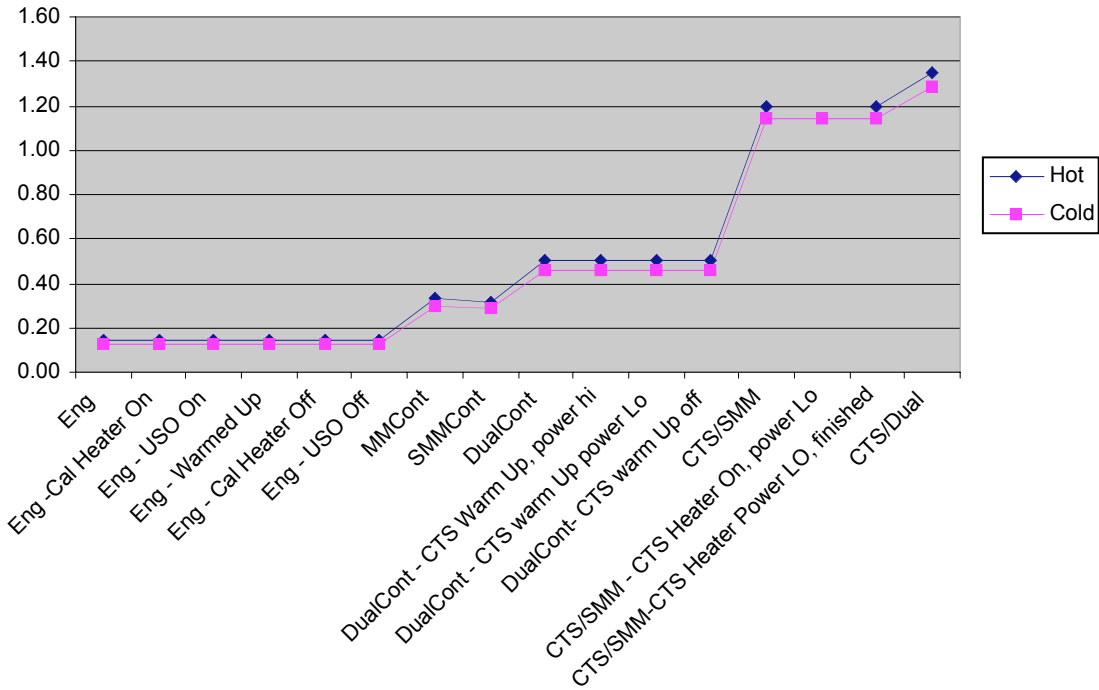



12V-1 Current SBEU [A]

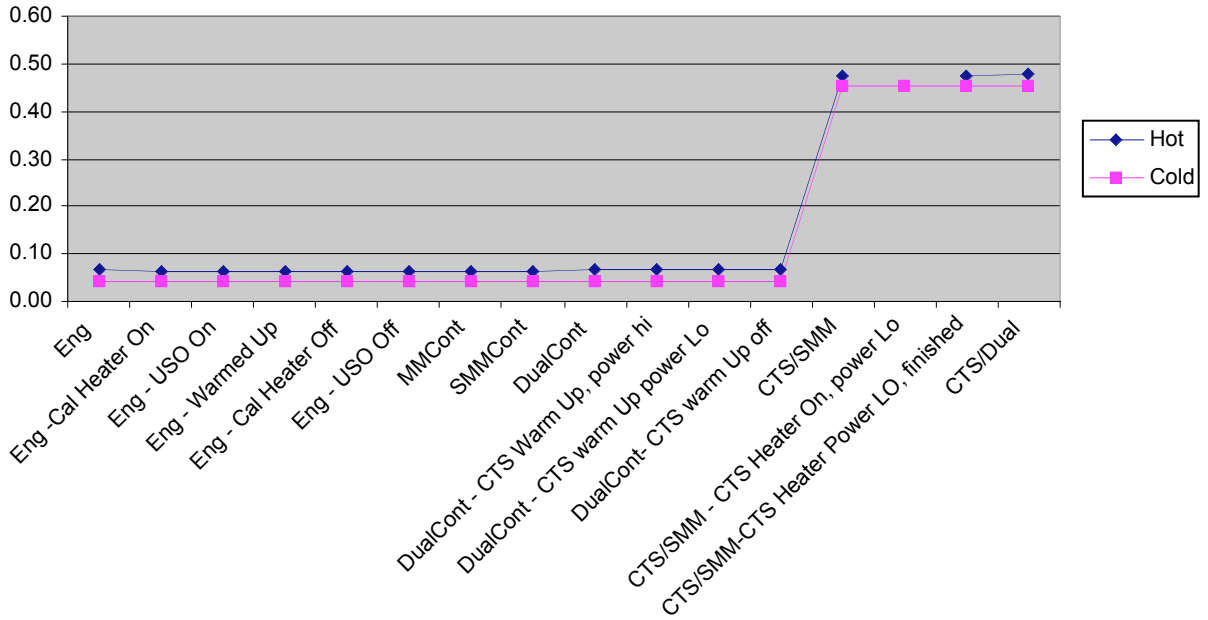

12V-2 Current SBEU [A]

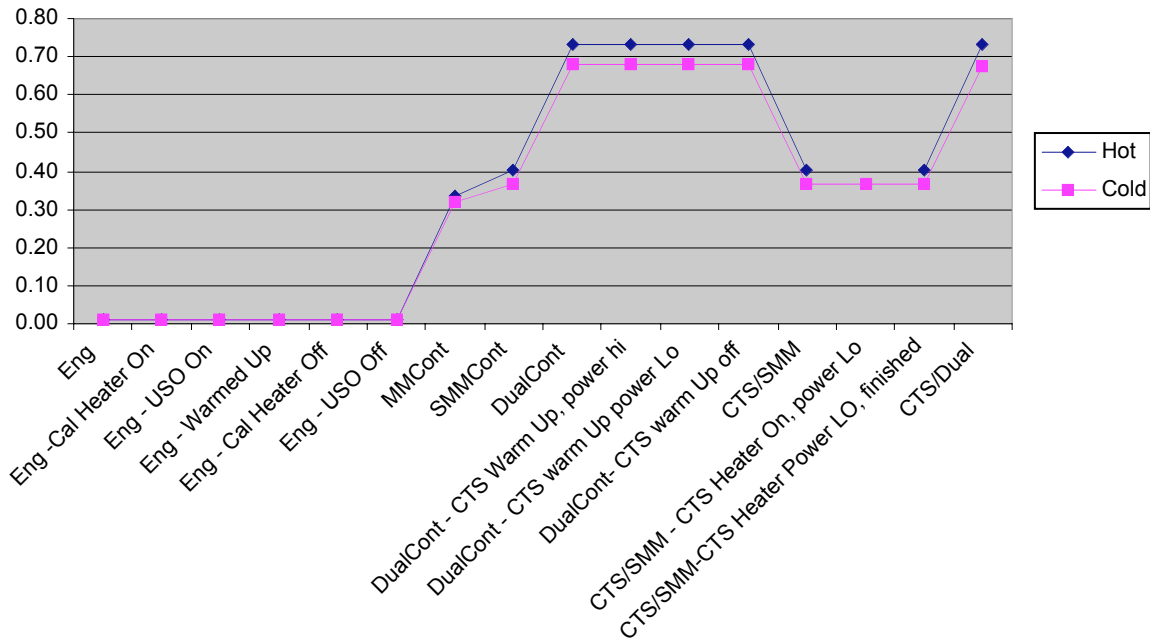

**-12V Current SBEU [A]**

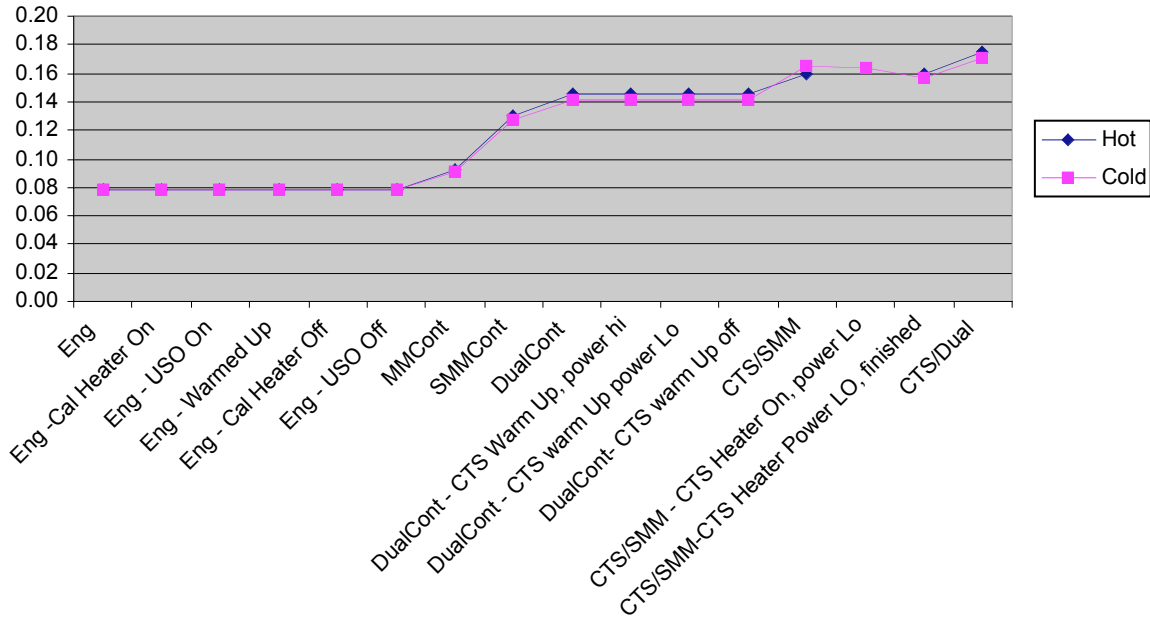

**MM Gunn Current [mA]**

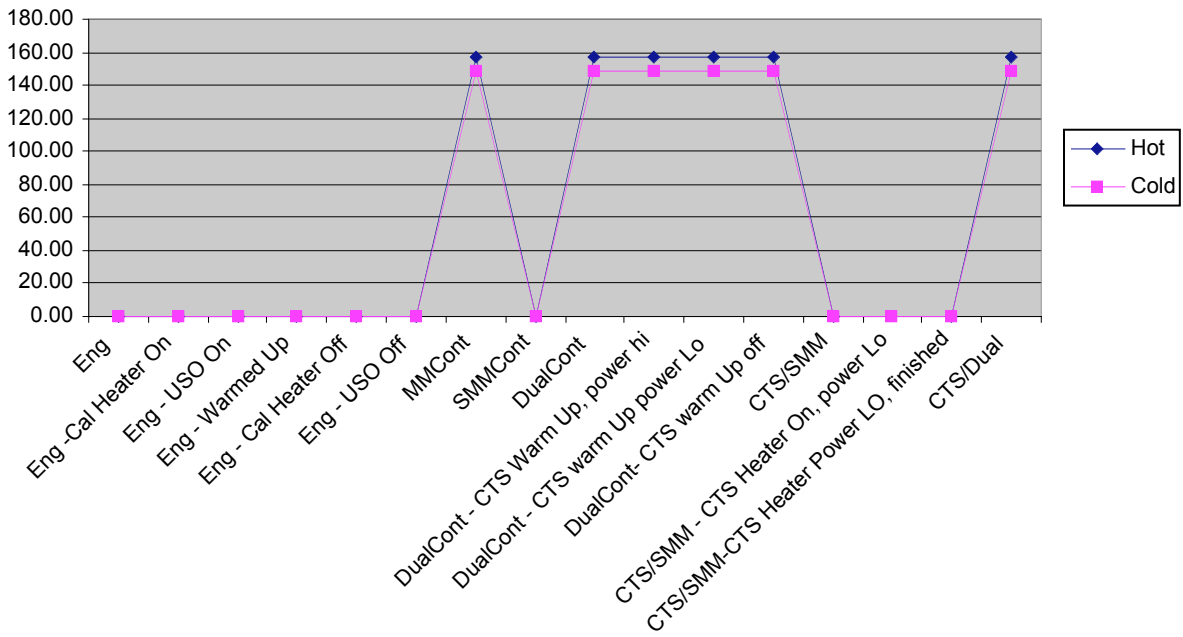

**SMM PLL Error [V]**

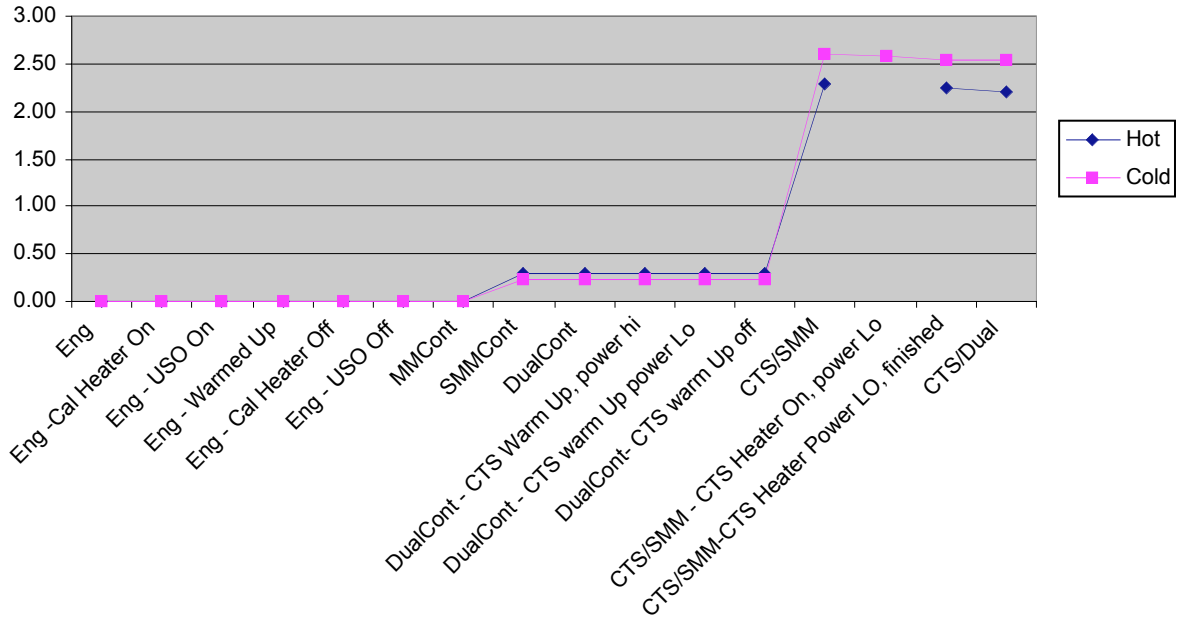

**FS1 Error [V]**

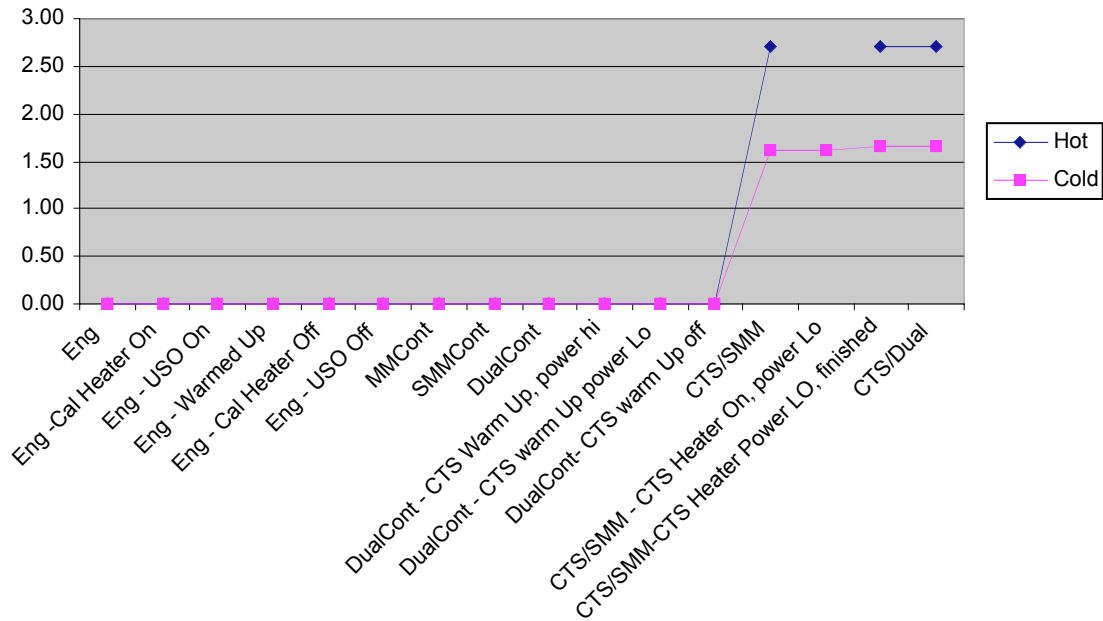

**FS2 Error [V]**

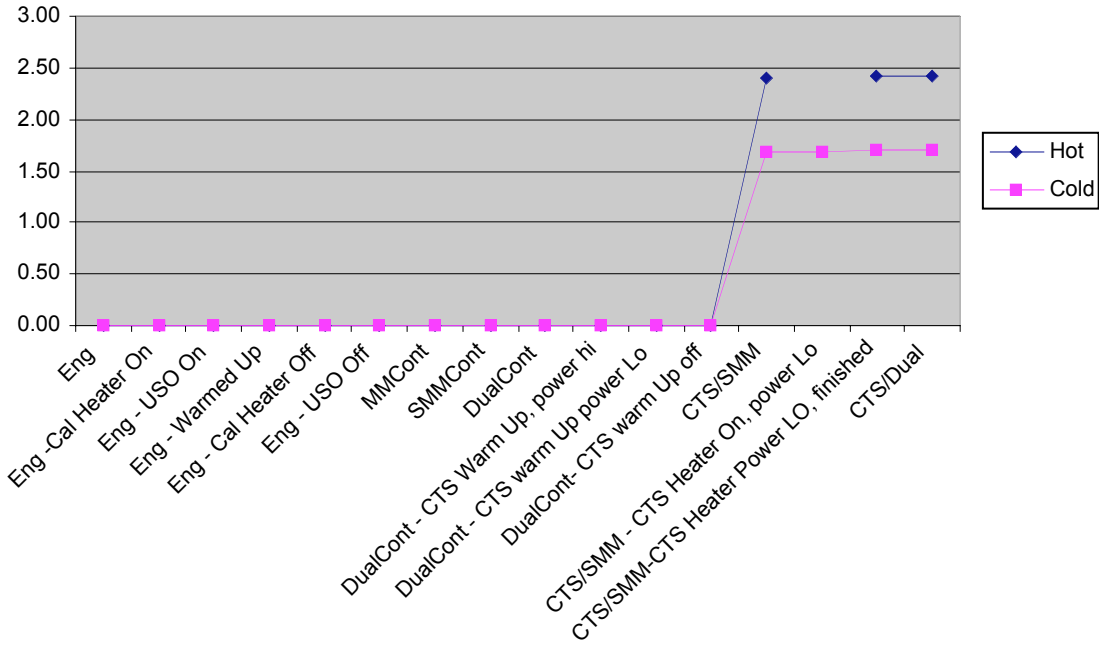

**FS3 Error [V]**

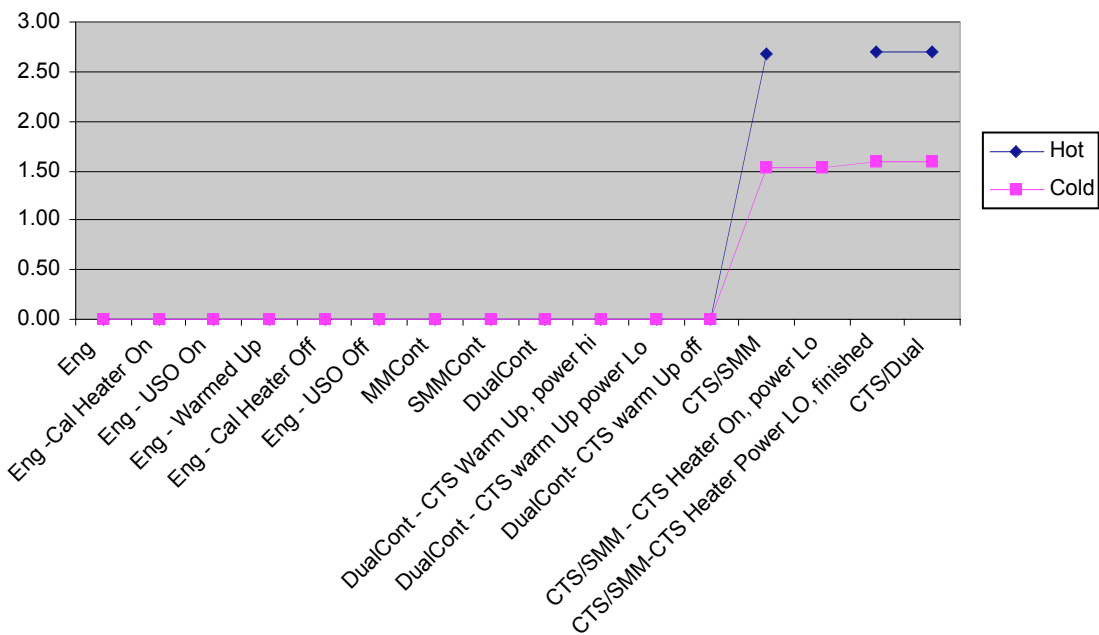

SMM Gunn Current [mA]

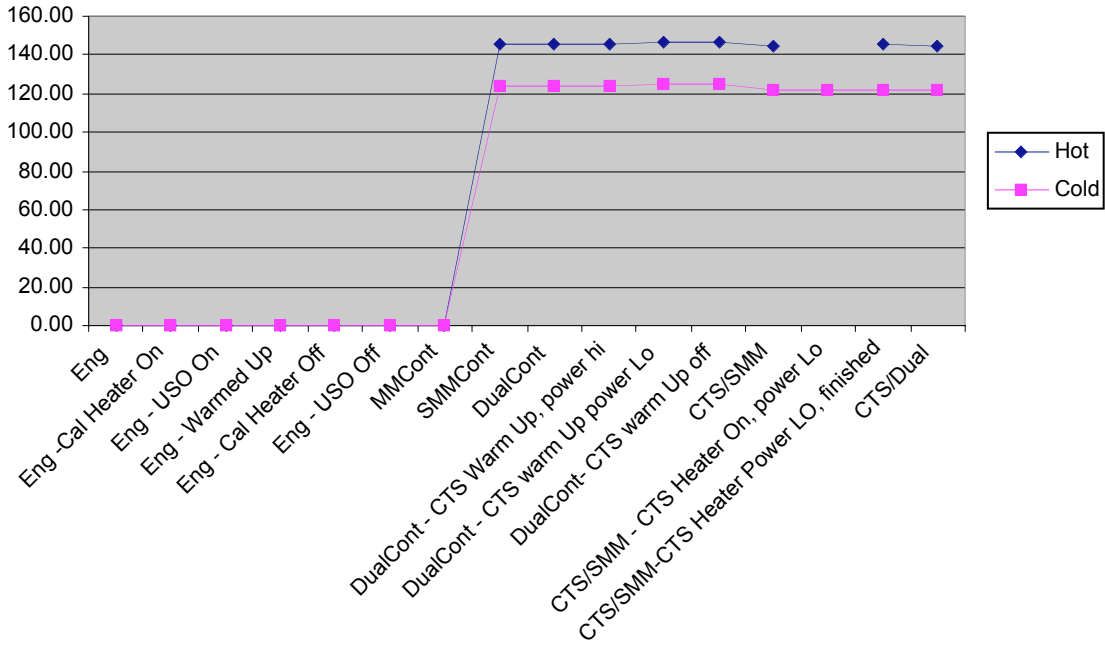

## 7.1.2.4 Calibration

### 7.1.2.4.1 Temperature Calibration

There are 21 Platinum Resistance Thermistors (PRT) in the MIRO instrument. The tables below provide both a second order and first order polynomial fit for the temperature as a function of raw data number for each PRT. The MIRO EGSE uses the second order fit. It provides the higher accuracy necessary to meet the temperature accuracy requirements. The 1<sup>st</sup> order fit is used by the Rosetta Data system to provide calibrated temperatures. The RSDB calibration data is used by ESA at download time to determine if an “out-of-limit” condition is met. This does not require the same degree of accuracy as the scientific use of the data.

#### EGSE 2<sup>nd</sup> order polynomial fit of temperature as a function of raw data number (DN).

PRT S/N	PRT Location	Subsys.	T[N] Coefficient A	T[N] Coefficient B	T[N] Coefficient C	Max. Residual Error [C]
			[C/DN <sup>2</sup> ]	[C/DN]	[C]	
PE40	Spect 1 (T_BRANCHA1)	EU	2.07883E-07	3.30314E-02	-19.726	0.078
PE41	Spect 2 (T_BRANCHA2)	EU	2.08406E-07	3.29487E-02	-20.227	0.077
PE53	Spect 3 (T_BRANCB1)	EU	2.09061E-07	3.31136E-02	-19.123	0.072
PE55	Spect 4 (T_BRANCB2)	EU	2.07419E-07	3.29994E-02	-19.888	0.072
PE44	Spect 5 (T_ANATRAY1)	EU	2.06196E-07	3.28688E-02	-20.823	0.076
PE62	Spect 6 (T_ANATRAY2)	EU	2.04410E-07	3.30287E-02	-20.060	0.065
JF72	EU TEMP	EU	2.10070E-07	3.28850E-02	-20.666	0.091
YK64	COLD-LOAD1 TEMP	SU	9.04375E-07	7.08852E-02	-182.322	0.004
YK68	COLD-LOAD2 TEMP	SU	9.05168E-07	7.13410E-02	-181.954	0.003
YG80	WARM-LOAD1 TEMP	SU	1.04532E-06	6.92694E-02	-181.685	0.346
YK69	WARM-LOAD2 TEMP	SU	1.03268E-06	6.92212E-02	-181.714	0.299
JF54	O/B TEMP	SU	1.08622E-06	6.96198E-02	-182.487	0.09
JF73	TELESCOPE-1 TEMP	SU	1.14824E-06	6.92175E-02	-182.003	0.268
LS46	TELESCOPE-2 TEMP	SU	1.07134E-06	6.86548E-02	-183.325	0.542
LS54	PLL-TEMP (S/N 02)	SBEU	8.26760E-07	7.01107E-02	-185.042	0.006
YK62	IFP-DET-T (smm) TEMP (SN02)	SBEU	8.79567E-07	6.99528E-02	-183.799	0.003
YK60	IFP-AMP-T (mm) TEMP (SN02)	SBEU	8.91920E-07	7.13595E-02	-183.029	0.004
LS41	SMM-LO-GUNN TEMP (SN02)	SU	8.51491E-07	7.02587E-02	-184.653	0.004
HZ55	MM-LO-GUNN TEMP (SN02)	SU	1.05513E-06	7.02858E-02	-182.608	0.064
JF57	MIRROR MOTOR TEMP	SU	1.08123E-06	6.95330E-02	-182.631	0.088
JF70	SEN-EL TEMP	SBEU	1.06962E-06	6.96692E-02	-182.699	0.083

## RSDB Linear fit of temperature as a function of raw data number

PRT S/N	PRT Location	Subsys	RSDB Name	T[N] coefficient m [C/DN]	T[N] coefficient b [C]	Max error at DN=0 [C]	Error at Dnmax [C]
PE40	Spect 1 (T_BRANCHA1)	EU	CMRY0100	0.033883675	-20.29413482	0.57	0.56
PE41	Spect 2 (T_BRANCHA2)	EU	CMRY0101	0.033803149	-20.79651699	0.57	0.57
PE53	Spect 3 (T_BRANCB1)	EU	CMRY0102	0.03397076	-19.69487753	0.57	0.57
PE55	Spect 4 (T_BRANCB2)	EU	CMRY0103	0.033849823	-20.45497342	0.57	0.56
PE44	Spect 5 (T_ANATRAY1)	EU	CMRY0104	0.033714199	-21.38677463	0.56	0.56
PE62	Spect 6 (T_ANATRAY2)	EU	CMRY0105	0.033866794	-20.61866605	0.56	0.55
JF72	EU TEMP	EU	CMRY0106	0.033746334	-21.23971713	0.57	0.57
YK64	COLD-LOAD1 TEMP	SU	CMRY0123	0.074412308	-184.5559698	2.23	2.07
YK68	COLD-LOAD2 TEMP	SU	CMRY0124	0.07487112	-184.189303	2.24	2.06
YG80	WARM-LOAD1 TEMP	SU	CMRY0125	0.07334614	-184.2668159	2.58	2.38
YK69	WARM-LOAD2 TEMP	SU	CMRY0136	0.073248693	-184.2651337	2.55	2.36
JF54	O/B TEMP	SU	CMRY0126	0.0740733	-185.4560633	2.97	2.95
JF73	TELESCOPE-1 TEMP	SU	CMRY0127	0.0739253	-185.1412464	3.14	3.12
LS46	TELESCOPE-2 TEMP	SU	CMRY0128	0.073047302	-186.2529661	2.93	2.91
LS54	PLL-TEMP (S/N 02)	SU	CMRY0129	0.073500419	-187.3020201	2.26	2.24
YK62	IFP-DET-TEMP (smm) (SN02)	SU	CMRY0130	0.073558985	-186.2027378	2.40	2.39
YK60	IFP-AMP-TEMP (mm) (SN02)	SU	CMRY0131	0.075016325	-185.4664865	2.44	2.42
LS41	SMM-LO-GUNN TEMP (SN02)	SU	CMRY0132	0.073749861	-186.9800848	2.33	2.31
HZ55	MM-LO-GUNN TEMP (SN02)	SU	CMRY0133	0.07461183	-185.4925038	2.88	2.86
JF57	MIRROR MOTOR TEMP	SU	CMRY0134	0.073966056	-185.5862737	2.96	2.93
JF70	SEN-EL TEMP	SU	CMRY0135	0.074054605	-185.623042	2.92	2.90

## 7.1.2.4.2 Voltage Calibration

There are 18 Voltages read out in the housekeeping data. The calibration for all of these is linear as given in the table below.

Description	RSDB Name	b [V]	m*Raw Data Number [V/DN]
+5 EU Voltage	CMRY0107	0	1.5647700E-03
+12 EU Voltage	CMRY0108	0	3.5557460E-03
-12 EU Voltage	CMRY0109	0	-5.7070700E-03
+3.3 EU Voltage	CMRY0110	0	9.4854200E-04
+24 EU Voltage	CMRY0111	0	1.2184308E-02
+5 Ana EU Voltage	CMRY0112	0	1.5863220E-03
USO TLM Heating Voltage	CMRY0119	0	1.2210012E-03
USO TLM RF Voltage	CMRY0120	0	1.2210012E-03
CTS-Ana-1 Voltage	CMRY0121	0	1.5258790E-03
CTS-Ana-2 Voltage	CMRY0122	0	1.5258790E-03
+5V SBEU Voltage	CMRY0137	0	1.5561130E-03

Description	RSDB Name	b [V]	m*Raw Data Number [V/DN]
+12-1 SBEU Voltage	CMRY0138	0	3.5520800E-03
+12-2 SBEU Voltage	CMRY0139	0	3.5574990E-03
-12 SBEU Voltage	CMRY0140	0	-5.8037160E-03
SMM-PLL-ERR Voltage	CMRY0147	0	9.3155000E-04
FS1-ERR Voltage	CMRY0148	0	1.2207030E-03
FS2-ERR Voltage	CMRY0149	0	1.2207030E-03
FS3-ERR Voltage	CMRY0150	0	1.2207030E-03

The USO Telemetry Heating Voltage and RF Voltage are not calibrated for temperature and power.

#### 7.1.2.4.3 Current Calibration

There are 12 Currents read out in the housekeeping data. The calibration for all of these is linear as given in the table below.

Description	Units	RSDB Name	b [A or mA]	m*Raw Data Number [A or mA/DN]
+5V EU Current	A	CMRY0113	0	7.6320000E-04
+12V EU Current	A	CMRY0114	0	2.2749800E-04
-12V EU Current	A	CMRY0115	0	2.6894900E-05
+24V EU Current	A	CMRY0116	0	2.1656800E-04
+3.3V EU Current	A	CMRY0117	0	1.1616000E-03
+5V Ana EU Current	A	CMRY0118	0	1.3607000E-04
+5V SBEU Current	A	CMRY0141	0	3.3313900E-04
+12V-1 SBEU Current	A	CMRY0142	0	2.7165900E-04
+12V-2 SBEU Current	A	CMRY0143	0	2.1425100E-04
-12V SBEU Current	A	CMRY0144	0	4.6708500E-05
MM Gunn Current	mA	CMRY0145	0	1.5258789E-01
SMM-PLL Gunn Current	mA	CMRY0151	0	6.2948800E-02

#### 7.1.2.4.4 Other Calibration



## 7.1.2.5 Limits

The limits are based on values obtained during thermal vacuum testing at JPL. The general approach was to set the soft limit at least 10% beyond the expected difference between the maximum and minimum expected value and the hard limit at least 20% beyond the expected values.

Telemetry Name	RSDB Name	Units	Condition	Hard Low	Soft Low	Soft High	Hard High
Spect_T1	LMR10023	C	CTS/Smm Cntm or CTS/Dual Cntm	-40.0	-35.0	80.0	85.0
Spect_T2	LMR20023	C	CTS/Smm Cntm or CTS/Dual Cntm	-40.0	-35.0	80.0	85.0
Spect_T3	LMR30023	C	CTS/Smm Cntm or CTS/Dual Cntm	-40.0	-35.0	80.0	85.0
Spect_T4	LMR40023	C	CTS/Smm Cntm or CTS/Dual Cntm	-40.0	-35.0	80.0	85.0
Spect_T5	removed	C	Fails intermitantly at high temperatures				
Spect_T6	LMR60023	C	CTS/Smm Cntm or CTS/Dual Cntm	-40.0	-35.0	80.0	85.0
EU_Temp	LMR00021	C	TRUE for all modes	-30	-20	50	60
ECal_Temp	LMR00022	Raw	TRUE for all modes	2585	2595	2630	2640
+5V_EU	LMR00024	V	TRUE for all modes	4.5	4.7	5.3	5.5
+12V_EU	LMR00025	V	TRUE for all modes	11.0	11.5	13.4	13.5
-12V_EU	LMR00026	V	TRUE for all modes	-13.5	-13.2	-11.5	-11.0
+3.3V_EU	LMR00027	V	TRUE for all modes	2.9	3.1	3.6	3.7
+24V_EU	LMR00029	V	TRUE for all modes	22.0	22.5	26.5	27.0
+5V_Ana_EU	LMR00028	V	TRUE for all modes	4.5	4.7	5.3	5.5
+5V_Curr_EU	LMR00030	A	TRUE for all modes	0	0.1	3	3.3
+12V_Curr_EU	LMR00031	A	TRUE for all modes	0	0.01	0.8	0.9
-12V_Curr_EU	LMR00032	A	TRUE for all modes	0	0.01	0.11	0.113
+24V_Curr_EU	LMR00035	A	TRUE for all modes	0	0.01	0.8	0.83
+3.3V_Curr_EU	LMR00033	A	TRUE for all modes	0	0.01	2.0	3.0
+5V_Ana_Curr_EU	LMR00034	A	TRUE for all modes	0	0.01	0.8	1.0
TLM_Heating	removed	V	Calibration not understood				
TLM_RF	removed	V	Calibration not understood				
CTS_V_Ana_1	LMR10038	V	CTS/Smm Cntm or CTS/Dual Cntm	2.4	2.43	2.6	2.65
CTS_V_Ana_2	LMR20038	V	CTS/Smm Cntm or CTS/Dual Cntm	2.4	2.43	2.6	2.65
Cold_Load1_Temp	LMR10039	C	TRUE for all modes	-183.0	-180.0	105.0	107.0
Cold_Load2_Temp	LMR20039	C	TRUE for all modes	-183.0	-180.0	105.0	107.0
Warm_Load1_Temp	LMR10040	C	TRUE for all modes	-30.0	-20.0	75.0	85.0
Warm_Load2_Temp	LMR20040	C	TRUE for all modes	-30.0	-20.0	75.0	85.0
OB_Temp	LMR00041	C	TRUE for all modes	-30.0	-20.0	35.0	40.0
PAY412-MIRO Temp 2 A Limits (Rosetta TRP)	LMR00074	C	MIRO off	-30.0	-25.0	55.0	60.0
PAY412-MIRO Temp 2 A Limits (Rosetta TRP)	LMR00074	C	TRUE for all modes	-20.0	-15.0	40.0	45.0
PAY413-MIRO Temp 2 B Limits (Rosetta TRP)	LMR00075	C	MIRO Off	-30.0	-25.0	55.0	60.0
PAY413-MIRO Temp 2 B Limits (Rosetta TRP)	LMR00075	C	TRUE for all modes	-20.0	-15.0	40.0	45.0
PAY414-MIRO Temp 1 A Limits (Rosetta TRP)	LMR00076	C	MIRO off	-30.0	-25.0	55.0	60.0
PAY414-MIRO Temp 1 A Limits (Rosetta TRP)	LMR00076	C	TRUE for all modes	-20.0	-15.0	55.0	65.0
Telescope1_Temp	LMR00071	C	TRUE for all modes	-183.0	-180.0	105.0	107.0
Telescope2_Temp	LMR00072	C	TRUE for all modes	-183.0	-180.0	105.0	107.0
PLL_Temp	LMR00042	C	TRUE for all modes	-30.0	-20.0	70.0	75.0
IFP_DET_Temp	LMR00043	C	TRUE for all modes	-30.0	-20.0	65.0	70.0
IFP_AMP_Temp	LMR00044	C	TRUE for all modes	-30.0	-20.0	65.0	70.0
SMM_LO_GUNN	LMR00045	C	TRUE for all modes	-30.0	-20.0	45.0	50.0
MM_LO_GUNN	LMR00046	C	TRUE for all modes	-30.0	-20.0	45.0	50.0
Motor_Temp	LMR00047	C	TRUE for all modes	-30.0	-20.0	100.0	150.0
Sen_EI_Temp	LMR00048	C	TRUE for all modes	-30.0	-20.0	65.0	70.0
Cal_Temp_Low	LMR00049	Raw	TRUE for all modes	430	440	500	560
Cal_Temp_High	LMR00050	Raw	TRUE for all modes	3650	3700	3850	3900

Telemetry Name	RSDB Name	Units	Condition	Hard Low	Soft Low	Soft High	Hard High
+5V_SBEU	LMR00051	V	TRUE for all modes	4.5	4.7	5.3	5.5
+12V_1_SBEU	LMR00052	V	TRUE for all modes	11.0	11.5	12.6	13.0
+12V_2_SBEU	LMR00054	V	TRUE for all modes	11.0	11.5	12.5	13.0
-12V_SBEU	LMR00053	V	TRUE for all modes	-13.0	-12.9	-10.8	-10.3
+5V_Curr_SBEU	LMR00055	A	TRUE for all modes	0.001	0.01	1.5	1.6
+12V_Curr_1_SBEU	LMR00056	A	TRUE for all modes	0.001	0.01	0.55	0.6
+12V_Curr_2_SBEU	LMR00058	A	TRUE for all modes	0.001	0.01	0.83	0.89
-12V_Curr_SBEU	LMR00057	A	TRUE for all modes	0.001	0.01	0.2	0.25
MM_GUNN_Curr	LMR00063	mA	Mm Cntm, Dual Cntm, CTS/Dual Cntm	140.0	145.0	160.0	170.0
SMM_PLL_ERR	LMR00059	V	CTS/Smm Cntm or CTS/Dual Cntm	1.0	2.0	2.75	3.3
FS1_ERR	LMR00060	V	CTS/Smm Cntm or CTS/Dual Cntm	1.0	1.4	3.0	3.5
FS2_ERR	LMR00061	V	CTS/Smm Cntm or CTS/Dual Cntm	1.0	1.4	3.0	3.5
FS3_ERR	LMR00062	V	CTS/Smm Cntm or CTS/Dual Cntm	1.0	1.4	3.0	3.5
SMM_PLL_GUNN_Curr	LMR00063	mA	CTS/Smm Cntm or CTS/Dual Cntm	110.0	115.0	150.0	160.0

### 7.1.2.6 RSDB Entries

Telemetry Packet: YMR00001 – MIRO Housekeeping

Parameters: NMRAXxx – identified in table above

The telemetry parameters that have subparameters are listed here.

#### NMRA0002 – Operational Mode

NMRD0201 Power Mode  
 NMRD0202 CTS Integration Period  
 NMRD0203 Continuum Sum Value  
 NMRD0204 CTS Smoothing Value  
 NMRD0205 Reserved (not used)  
 NMRD0206 Reserved (not used)  
 NMRD0207 Reserved

#### NMRAH141 – MR71/4 PckSeqCount

NMRDH141 Segmentation Flag  
 NMRDH142 MR 71/4 SourceSeqCount

#### NMRAH143 – MR71/4 DataFieldHdr time

NMRDH143 MIRO 71/4 Coarse time  
 NMRDH144 MIRO 71/4 Fine time

#### NMRAH144 – MR71/4 DataFieldHdr PUS

NMRDH145 PUS version number  
 NMRDH146 Checksum flag  
 NMRDH147 Data field header spare  
 NMRDH148 MIRO 71/4 Packet Type  
 NMRDH149 MIRO 71/4 Packet Subtype  
 NMRDH140 Data field header pad

### 7.1.3 SPECTROSCOPIC (CTS) SCIENCE TELEMETRY

#### 7.1.3.1 Description

The submillimeter-wave spectroscopic frequencies allow simultaneous observations of 8 spectral lines; H<sub>2</sub>O (556.936 GHz), H<sub>2</sub><sup>17</sup>O (552.021 GHz), H<sub>2</sub><sup>18</sup>O (547.676 GHz), CO (576.268 GHz), NH<sub>3</sub> (572.498 GHz), and CH<sub>3</sub>OH (553.146, 568.566, 579.151 GHz). These lines are returned in 7 down converted bands, 20 MHz wide, that are spectrally analyzed by the Chirp Transform Spectrometer (CTS).

Band 1 (1270 MHz): H<sub>2</sub>O

Band 2 (1300 MHz): H<sub>2</sub><sup>17</sup>O

Band 3 (1320 MHz): CH<sub>3</sub>OH (579.151 GHz)

Band 4 (1340 MHz): H<sub>2</sub><sup>18</sup>O

Band 5 (1363 MHz): CO

Band 6 (1389 MHz): CH<sub>3</sub>OH (568.566 GHz)

Band 7 (1407, 1425 MHz): NH<sub>3</sub>, CH<sub>3</sub>OH (553.146 GHz)

Spectroscopic data is generated in three of the MIRO operating modes:

1. CTS/Submillimeter-wave Continuum mode.
2. CTS/Dual continuum mode.
3. Asteroid mode.

Two types of data are returned.

1. Calibration data
2. Differenced frequency switched data.

Each digitized spectrum contains 4096 43 KHz wide channels (unless CTS smoothing is invoked).

In addition to the spectroscopic data, additional related information is packaged in the spectroscopic science file. The first CTS science packet contains the operational mode, the science data type (in this case CTS data), the calibration mirror location, the CTS multiplier value, the calibration indicator, and the LO frequency setting. Last CTS science packet contains PLL alarm data for the CTS scan. One byte of PLL alarm data will be present for each 5-second CTS scan that is contained in the CTS data set.

## 7.1.3.2 Packet Definition

### Spectroscopic (CTS) Science Telemetry Definition

Data Element	RSDB Name	Size (bits)	Value (binary)	Comment
Version Number		3	000	EID-A Mandatory
Type		1	0	EID-A Mandatory
Data Field Header Flag		1	1	EID-A Mandatory
Application Process ID		7	1000111	EID-A Specified, 71
Packet Category		4	1100	EID-A Specified, Private (science) = 12
Segmentation Flags	NMRDH1C1	2	11	EID-A Mandatory
Source Sequence Count	NMRDH1C2	14	1 up counter	Zero initially, A separate counter is used for each APID/Packet Category combination (i.e. science, housekeeping, memory dump, etc.)
Packet Length	NMRAH1C2	16	110110111	This gets set to the size of the source data field (in bytes) + 9. This is 439 bytes.
Time	NMRAH1C3	48	Varies	Defines the time that the acquisition of the data within the packet was initiated. 4 bytes of seconds followed by 2 bytes of fractional seconds.
PUS Version	NMRDH1C5	3	000	EID-A Specified, Science data
Checksum Flag	NMRDH1C6	1	0	EID-A Mandatory
Spare	NMRDH1C7	4	0000	EID-A Mandatory
Packet Type	NMRDH1C8	8	00010100	EID-A Specified, Science Data Transfer = 20
Packet Subtype	NMRDH1C9	8	00000011	EID-A Specified, RTU Interface = 3
Pad	NMRDH1C0	8	00000000	EID-A Specified
Source Data		3440	430 bytes	Detailed definition on following page

## CTS Science Source Data Definition

Data Element	Size (Bits)	Value (Binary)	Comment
Operational mode	16		MIRO operational mode
Science data type	8	00000001	CTS data = 1
Mirror location	8		1=sky, 2=hot, 3=cold
CTS multiplier value	16	N	All CTS data values should be multiplied by $2^N$ , when a user defined CTS mask is in effect this will be zero.
Data set number	16	1 up counter	Specifies CTS data set number
Packet number	8		Specifies packet number within CTS data set
Calibration indicator	4		0=Calibration, 1=nominal CTS data
LO frequency setting	4		0=LO frequency 0, 1= LO frequency 1 Note: This setting only applies to calibration data as indicated by the calibration indicator.
CTS data	3360	420 bytes	Processed CTS data. Multiple data packets depending on value of CTS Smoothing Value. Note: Last CTS packet contains PLL alarm data for the CTS scan. One byte of PLL alarm data will be present for each 5-second CTS scan that is contained in the CTS data set. The 4 most significant bits of each PLL alarm byte represent the PLL alarm states at 0.05 seconds elapsed time into the scan. The 4 least significant bits indicate whether the corresponding PLL alarm bit ever changed. See details below.

Note: When the asteroid mode bit in the 'operational mode' data element is set the following CTS science data packet decoding rules apply: The 'calibration indicator' will always be zero even though some of the asteroid data is calibration data and some is not. All asteroid data sets are the same and consist of 4096 32-bit samples packed into 39 TM packets of 420 bytes each, and 1 packet of 4 bytes plus 1 byte of PLL data. The 'LO frequency setting' will indicate which LO frequency the data was captured at.

### 7.1.3.3 Expected Values

Typical spectra are shown below.

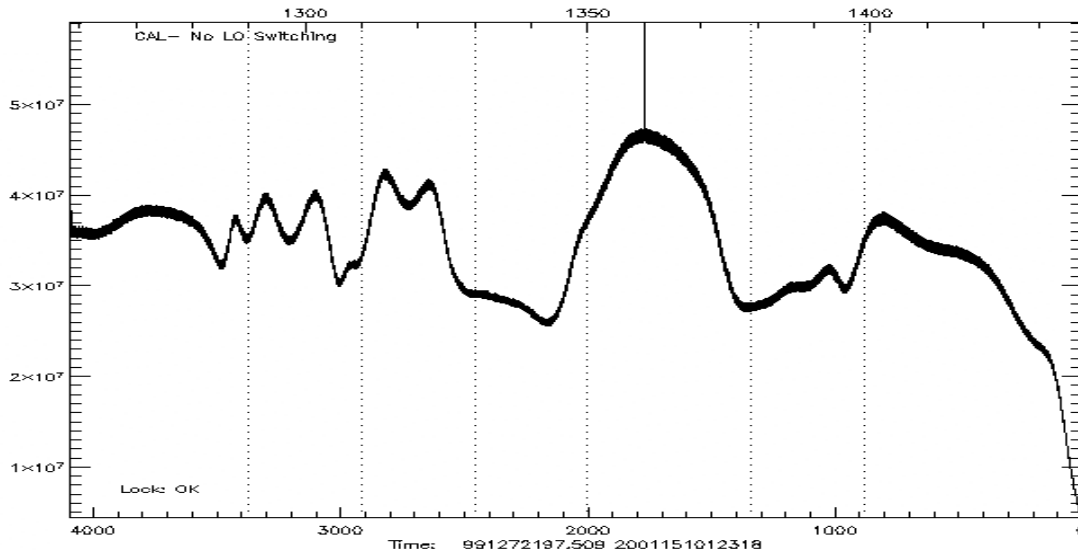

CTS calibration Data: Shown above is a typical CTS calibration data. The vertical scale is in counts (about  $4 \times 10^7$ ); the top horizontal scale in frequency (MHz), the bottom horizontal scale is in channel numbers. The CTS calibration data shows the structure of the IF band pass. The 7 bands are indicated by the dotted lines. Six of these scans are obtained for each calibration—(1) observing the hot load at +5 MHz, (2) observing the hot load at -5 MHz, (3) observing the cold load at +5 MHz, (4) observing the cold load at -5 MHz, (5) observing the source position at +5 MHz, and (6) observing the source position at -5 MHz. Since the count level is dominated by the receiver noise, these 6 scans look very similar. The spike at 1364.7 MHz is internal to the instrument. Though unintentional, it serves as a good indicator that the CTS pulse position is set correctly.

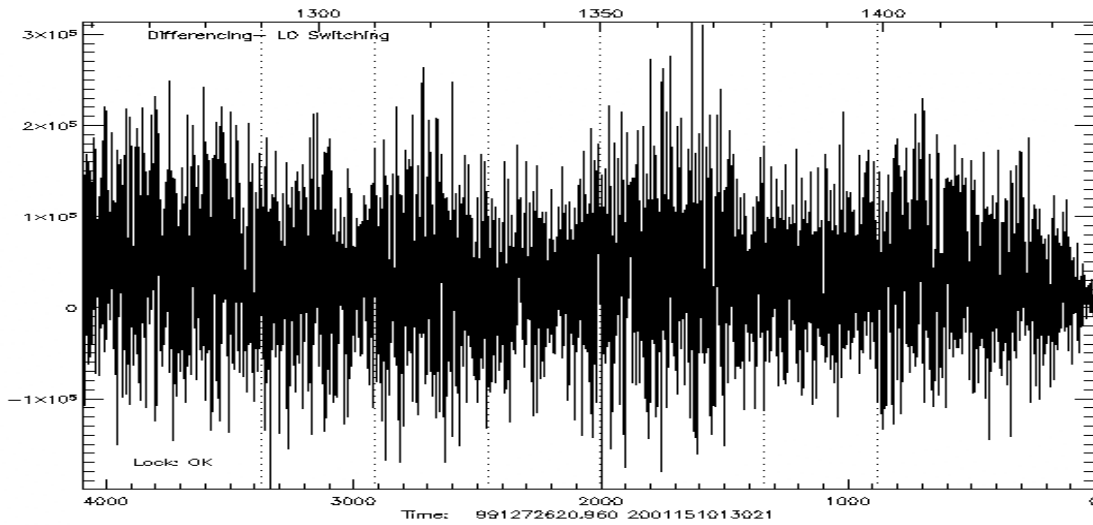

CTS differenced data is shown above. If there were no drift between the 5 second LO switches the data would be at 0 counts. In this figure it is slightly above 0 consistent with a linear increasing drift. The structure seen in the calibration data has been cancelled out. The seven bands are indicated by the dotted lines. The peak-to-peak signal is consistent with 30-second integration time, 43-kHz bandwidth, and receiver noise temperature of about 5000 K.

**PLL Alarm Bits (additional detail)**

The PLL alarm bits are comprised of 6 individual bits that are tracked during the CTS scans. The 6 bits are shown in the table below:

Frequency Synthesizer 3	Frequency Synthesizer 2	Frequency Synthesizer 1	SMM Low	SMM High	LO Frequency
-------------------------	-------------------------	-------------------------	---------	----------	--------------

The 3 MSB are the 3 frequency synthesizer alarms. The 3 LSB are the 3 PLL alarms. For the frequency synthesizer alarm bits 1 = locked and 0 = alarm condition. For the PLL alarm bits 0 = locked and 1 = alarm condition. Since the number of bits was increased from 4 in the EQM to 6 in the flight a scheme was developed to consolidate the 6 bits down to 4 to generate the same amount of returned telemetry. The 3 frequency synthesizer bits are ANDed together upon their initial sampling on continuum sample number 1. If all 3 bits are 1, indicating lock, then the initial value of the consolidated frequency synthesizer bit will be 1. If any of the 3 frequency synthesizer bits are 0 then the consolidated frequency synthesizer bit will be 0. The 3 PLL alarm bits have an initial state that corresponds directly to the 0 or 1 returned from the hardware. The table below shows the 4 bits that comprise the initial alarm bit state as returned in the 4 MSB of the alarm data for each CTS scan:

Consolidated Frequency Synthesizer Bit	SMM Low	SMM High	LO Frequency
--	---------	----------	--------------

These 4 bits show the initial state of the alarms as sampled during the first continuum sample approximately 50 milliseconds into the CTS scan. There are 99 remaining continuum samples during the 5 second CTS scan. The 4 LSB of the alarm data are used to indicate if the alarm bits ever change from their initial state at any time during the remaining 99 samples. For the 3 PLL bits it is very straightforward. If the initial state ever changes, the 'change bit' in the 4 LSB will show a 1. If the PLL alarm never changes then the 'change bit' will show a 0. The final returned 8 bits are shown below:

Consolidated Frequency Synthesizer Bit	SMM Low	SMM High	LO Frequency	Consolidated Frequency Synthesizer Change Bit	SMM Low Change Bit	SMM High Change Bit	LO Frequency Change Bit
--	------------	-------------	-----------------	--	-----------------------------	------------------------------	-------------------------------

The consolidated frequency synthesizer change bit works as follows. If any of the 3 initial frequency synthesizer bits changes from its initial value during the CTS scan, the change bit will be set to 1. If none of the 3 bits change during the scan then the change bit will be set to 0. The 3 frequency synthesizer bits were consolidated because it was determined that they were likely to be the most stable of the 6 alarm bits. If the 3 frequency synthesizers are working perfectly and never lose lock during a CTS scan then the returned bit pair should be 1-0. Since they are consolidated it will not be possible to determine exactly which one is losing lock should one or more of them lose lock. Since each of the 3 PLL alarm bits is separately tracked it will be possible to determine which of them is losing lock during each scan.

#### 7.1.3.4 Calibration

The absolute calibration of the instrument is obtained by observing two blackbody loads at two different temperatures. The cold load is exposed to space, while the hot target is located inside the spacecraft and can be heated. Calibration occurs automatically about every 30 minutes.

For spectroscopic observations, the submillimeter-wave receiver is operated in a "frequency switched" mode to eliminate residual baseline ripple. For half the integration time, the signal frequency is shifted 5 MHz above the nominal frequency, while the other half of the time it is shifted to 5 MHz below. The frequency switching occurs every 5 seconds. The -5MHz data is subtracted from the +5 MHz data by the on-board computer.

The calibration data is not differenced. It consists of 6 scans each with 30 seconds integration time.

1. Hot load with LO switched to +5MHz
2. Hot Load with the LO switched to -5MHz
3. Cold load with the LO switched to +5Mhz



4. Cold Load with the LO switched to  $-5\text{MHz}$
5. Source with the LO switched to  $+5\text{ MHz}$
6. Source with the LO switched to  $-5\text{ MHz}$

#### **7.1.3.5 RSDB Entries**

The Spectroscopic data file YMR00011. Some of the header values are called specifically with NMR..... designations. These are indicated in the above tables.

## 7.1.4 SUBMILLIMETER CONTINUUM SCIENCE TELEMETRY

### 7.1.4.1 Description

The submillimeter-wave receiver provides continuum data as well as spectroscopic data. The submillimeter-wave continuum band is 1 GHz wide centered at 569.813 GHz (USB) and 555.813 GHz (LSB), since the receiver is double sideband.

Submillimeter-wave continuum data is taken in 5 MIRO operating modes.

1. Submillimeter continuum mode.
2. Dual continuum mode.
3. CTS/Submillimeter continuum mode.
4. CTS/Dual continuum mode.
5. Asteroid mode.

A continuous digitized stream of data is returned. The integration time per data point defaults to 50. It is controlled by the continuum summing parameter in the Change Mode telecommand. The data output will be summed over 50 ms (1 continuum value summed), 100 ms (2 continuum values summed), 250 ms (5 continuum values summed), 500 ms (10 continuum values summed) or 1000 ms (20 continuum values summed). A fixed value may be subtracted from these measurements depending on whether or not the Continuum Subtraction Value telecommand has been executed. The subtraction value is contained in the miscellaneous science file. When the summing value is set to either 1 or 2, additional timestamps are placed in the continuum packet.

In addition to the spectroscopic data, additional related information is packaged in the spectroscopic science file. The first CTS science packet contains the operational mode, the science data type (in this case submillimeter-wave continuum data), the calibration mirror location, MM subtraction value, SMM subtraction value, the calibration indicator, and the LO frequency setting. In addition time tags are applied approximately every 5 seconds. If in a spectroscopic mode is on, then the level is changed by LO frequency switching.

## 7.1.4.2 Packet Telemetry Definition

Data Element	RSDB Name	Size (bits)	Value (binary)	Comment
Version Number		3	000	EID-A Mandatory
Type		1	0	EID-A Mandatory
Data Field Header Flag		1	1	EID-A Mandatory
Application Process ID		7	1000111	EID-A Specified, 71
Packet Category		4	1100	EID-A Specified, Private (science) = 12
Segmentation Flags	NMRDH1C1	2	11	EID-A Mandatory
Source Sequence Count	NMRDH1C2	14	1 up counter	Zero initially, A separate counter is used for each APID/Packet Category combination (i.e. science, housekeeping, memory dump, etc.)
Packet Length	NMRAH1C2	16	Varies	This gets set to the size of the source data field (in bytes) + 9. This is nominally 439 bytes, but can be as small as 49 depending on the number of samples contained in the packet.
Time	NMRAH1C3	48	Varies	Defines the time that the acquisition of the data within the packet was initiated. 4 bytes of seconds followed by 2 bytes of fractional seconds.
PUS Version	NMRDH1C5	3	000	EID-A Specified, Science data
Checksum Flag	NMRDH1C6	1	0	EID-A Mandatory
Spare	NMRDH1C7	4	0000	EID-A Mandatory
Packet Type	NMRDH1C8	8	00010100	EID-A Specified, Science Data Transfer = 20
Packet Subtype	NMRDH1C9	8	00000011	EID-A Specified, RTU Interface = 3
Pad	NMRDH1C0	8	00000000	EID-A Specified
Source Data		Varies	40-430 bytes	Detailed definition on following page

## Continuum (Sub-Millimeter) Source Data Definition

Data Element	Size (bits)	Value (binary)	Comment
Operational mode	16		MIRO Operational mode
Science data type	8	00000010	Sub-Millimeter data = 2
Mirror location	8		1=sky, 2=hot, 3=cold
Calibration indicator	16		0=Calibration, 1=nominal CTS data
MM subtraction value	16		Current value as uplinked via TC
SMM subtraction value	16		Current value as uplinked via TC
Reserved	16	0000000000000000	
Timestamp 2	48		Time of 101 <sup>st</sup> continuum sample if continuum summing value is 1. Time of 51 <sup>st</sup> continuum sample if continuum summing value is 2. Zero otherwise.
Timestamp 3	48		Time of 101 <sup>st</sup> continuum sample if continuum summing value is 2. Zero otherwise.
Timestamp 4	48		Time of 151 <sup>st</sup> continuum sample if continuum summing value is 2. Zero otherwise
Continuum Data	Varies	10-400 bytes	Field is nominally 400 bytes, but can be as short as 10 bytes if flushed for a mode change. Alternating sets of continuum data at LO1 and LO2 if CTS running. Size of each set depends on continuum summing value.

### 7.1.4.3 Expected Value

Typical submillimeter continuum data are shown below. The first scan shown below is typical of a non-spectroscopic mode—either submillimeter-continuum mode or dual continuum mode. The vertical axis in the plot above is counts. The horizontal scale is time, in this case in minutes. In addition to the source date (about 7880 counts), the effect of a calibration sequence is seen as well. The higher level (about 7900 counts) results from observing the hot load for 30 seconds, while the lower level (about 7780 counts) results from observing the cold load for 30 seconds.

The second scan below shows typical submillimeter continuum data in a spectroscopic mode—either CTS/submillimeter continuum mode or CTS/dual continuum mode. The effect of the +-5MHz frequency switching every 5 seconds is clearly seen by a slight change in level. To process this data, it is necessary to bin it into the appropriate frequency switch before applying the calibration.

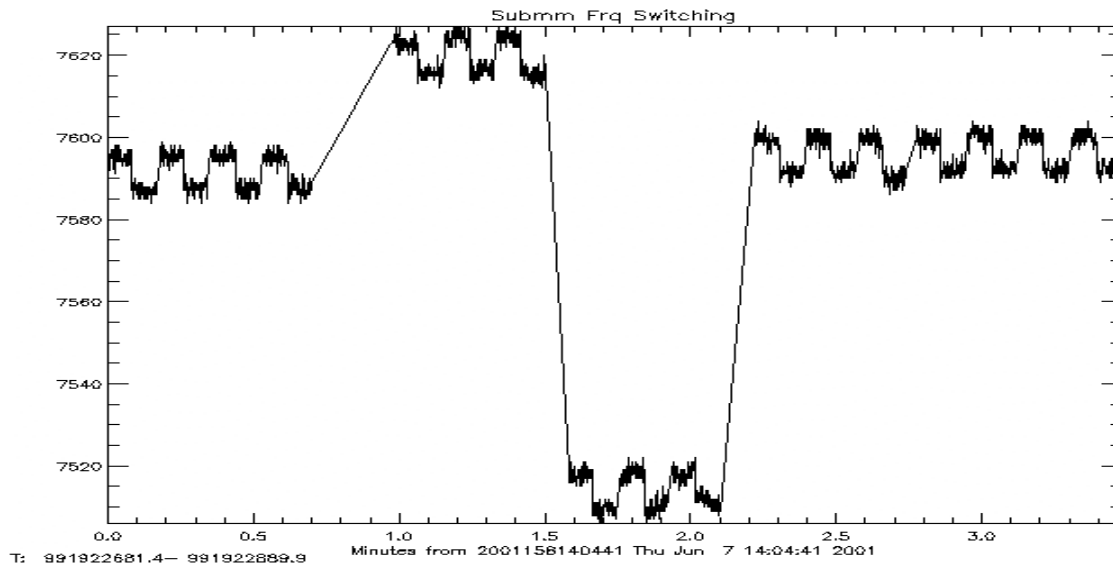
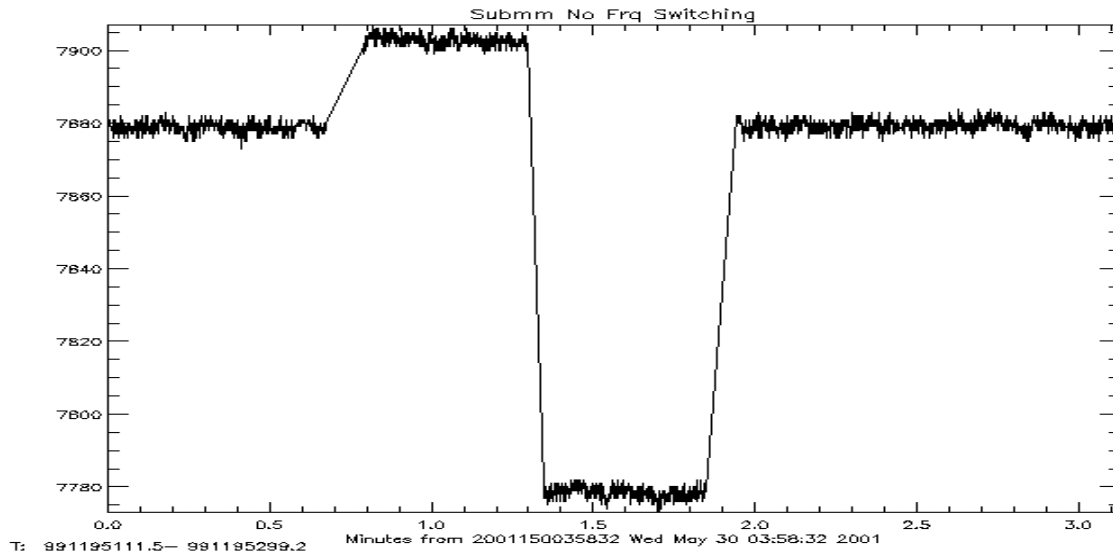

**7.1.4.4 Calibration**

The absolute calibration of the instrument is obtained by observing two blackbody loads at two different temperatures. The cold load is exposed to space, while the hot target is located inside the spacecraft and can be heated. Calibration occurs automatically about every 30 minutes.

**7.1.4.5 RSDB Entries**

The Spectroscopic data file YMR00011. Some of the header values are called specifically with NMR..... designations. These are indicated in the above tables.

## **7.1.5 MILLIMETER CONTINUUM SCIENCE TELEMETRY**

### **7.1.5.1 Description**

The millimeter-wave receiver provides continuum data. The millimeter-wave continuum band is 500 MHz wide centered at about 188.75 GHz (LSB) and 191.25 GHz (USB), since the receiver is double sideband. Note that the LO is not locked so that these are as uncertain as the LO frequency.

Millimeter-wave continuum data is taken in 4 MIRO operating modes.

1. Millimeter continuum mode.
2. Dual continuum mode.
3. CTS/Dual continuum mode.
4. Asteroid mode.

A continuous digitized stream of data is returned. The integration time per data point defaults to 50. It is controlled by the continuum summing parameter in the Change Mode telecommand. The data output will be summed over 50 ms (1 continuum value summed), 100 ms (2 continuum values summed), 250 ms (5 continuum values summed), 500 ms (10 continuum values summed) or 1000 ms (20 continuum values summed). A fixed value may be subtracted from these measurements depending on whether or not the Continuum Subtraction Value telecommand has been executed. The subtraction value is contained in the Miscellaneous Science file. When the summing value is set to either 1 or 2, additional timestamps are placed in the continuum packet.

## 7.1.5.2 Packet Telemetry Definition

Data Element	RSDB Name	Size (bits)	Value (binary)	Comment
Version Number		3	000	EID-A Mandatory
Type		1	0	EID-A Mandatory
Data Field Header Flag		1	1	EID-A Mandatory
Application Process ID		7	1000111	EID-A Specified, 71
Packet Category		4	1100	EID-A Specified, Private (science) = 12
Segmentation Flags	NMRDH1C1	2	11	EID-A Mandatory
Source Sequence Count	NMRDH1C2	14	1 up counter	Zero initially, A separate counter is used for each APID/Packet Category combination (i.e. science, housekeeping, memory dump, etc.)
Packet Length	NMRAH1C2	16	Varies	This gets set to the size of the source data field (in bytes) + 9. This is nominally 439 bytes, but can be as small as 49 depending on the number of samples contained in the packet.
Time	NMRAH1C3	48	Varies	Defines the time that the acquisition of the data within the packet was initiated. 4 bytes of seconds followed by 2 bytes of fractional seconds.
PUS Version	NMRDH1C5	3	000	EID-A Specified, Science data
Checksum Flag	NMRDH1C6	1	0	EID-A Mandatory
Spare	NMRDH1C7	4	0000	EID-A Mandatory
Packet Type	NMRDH1C8	8	00010100	EID-A Specified, Science Data Transfer = 20
Packet Subtype	NMRDH1C9	8	00000011	EID-A Specified, RTU Interface = 3
Pad	NMRDH1C0	8	00000000	EID-A Specified
Source Data		Varies	40-430 bytes	Detailed definition on following page

**Continuum (Millimeter) Source Data Definition**

Data Element	Size (bits)	Value (binary)	Comment
Operational mode	16		MIRO Operational mode
Science data type	8	00000011	Millimeter data = 3
Mirror location	8		1=sky, 2=hot, 3=cold
Calibration indicator	16		0=Calibration, 1=nominal CTS data
MM subtraction value	16		Current value as uplinked via TC
SMM subtraction value	16		Current value as uplinked via TC
Reserved	16	0000000000000000	
Timestamp 2	48		Time of 101 <sup>st</sup> continuum sample if continuum summing value is 1. Time of 51 <sup>st</sup> continuum sample if continuum summing value is 2. Zero otherwise.
Timestamp 3	48		Time of 101 <sup>st</sup> continuum sample if continuum summing value is 2. Zero otherwise.
Timestamp 4	48		Time of 151 <sup>st</sup> continuum sample if continuum summing value is 2. Zero otherwise
Continuum Data	Varies	10-400 bytes	Field is nominally 400 bytes, but can be as short as 10 bytes if flushed for a mode change. Alternating sets of continuum data at LO1 and LO2 if CTS running. Size of each set depends on continuum summing value.

**7.1.5.3 Expected Values**

Typical millimeter-wave continuum data is shown below. The vertical axis in the plot above is counts. The horizontal scale is time, in this case in minutes. In addition to the source date (about 7335 counts), the effect of a calibration sequence is seen as well. The higher level (about 7400 counts) results from observing the hot load for 30 seconds, while the lower level (about 7000 counts) results from observing the cold load for 30 seconds.



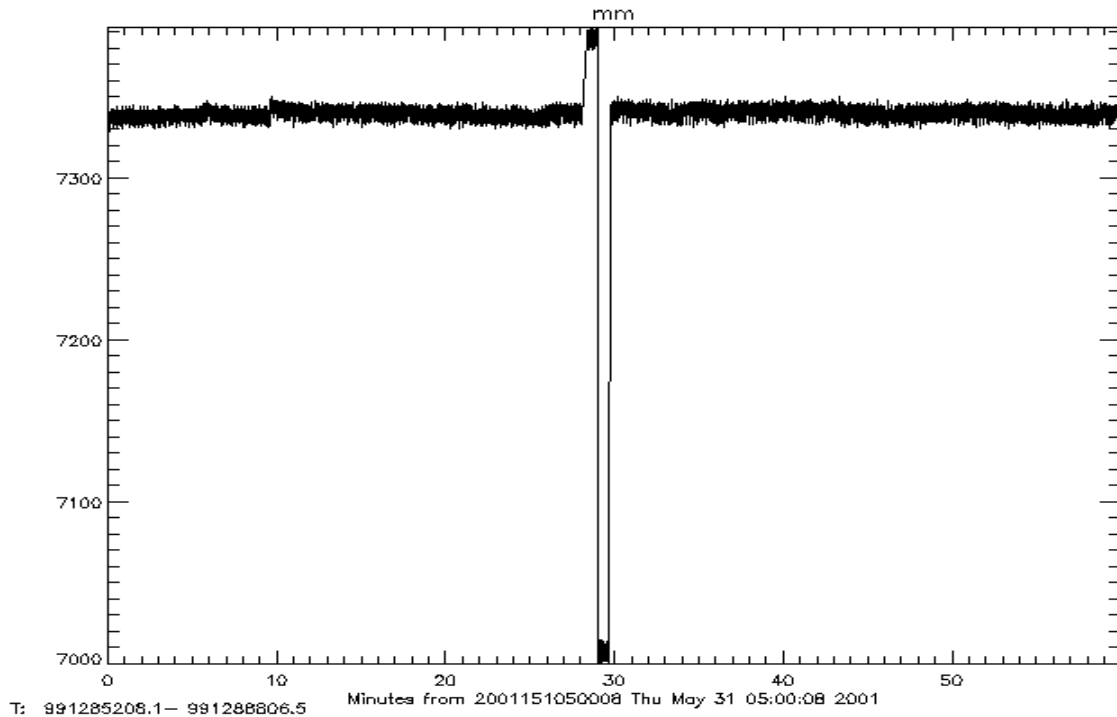

#### 7.1.5.4 Calibration

The absolute calibration of the instrument is obtained by observing two blackbody loads at two different temperatures. The cold load is exposed to space, while the hot target is located inside the spacecraft and can be heated. Calibration occurs automatically about every 30 minutes.

#### 7.1.5.5 RSDB Entries

The Spectroscopic data file YMR00011. Some of the header values are called specifically with NMR..... designations. These are indicated in the above tables.

## 7.1.6 MISCELLANEOUS SCIENCE TELEMETRY

### 7.1.6.1 Description

The miscellaneous science telemetry contains parameters critical to analyzing the data that are not captured in the other science files.

A Miscellaneous Science file is generated under the following circumstances:

1. Whenever a mode change takes place. This happens not only on a Mode Change command, but also automatically with the following telecommands: CTS Internal Cal, IFP Power Control and Asteroid Mode.
2. During autonomously executed calibration sequences that take place roughly every 30 minutes following a Mode Change telecommand.
3. When the CTS Data Mask telecommand is executed.
4. When a CTS internal table calibration takes place. (Per this and item 1, the CTS Internal Cal telecommand generates two MS packets, while the Asteroid mode command, which has two mode changes and a cal, generates three.)

### 7.1.6.2 Packet Definition

Data Element	RSDB Name	Size (bits)	Value (binary)	Comment
Version Number		3	000	EID-A Mandatory
Type		1	0	EID-A Mandatory
Data Field Header Flag		1	1	EID-A Mandatory
Application Process ID		7	1000111	EID-A Specified, 71
Packet Category		4	1100	EID-A Specified, Private (science) = 12
Segmentation Flags	NMRDH1C1	2	11	EID-A Mandatory
Source Sequence Count	NMRDH1C2	14	1 up counter	Zero initially, A separate counter is used for each APID/Packet Category combination (i.e. science, housekeeping, memory dump, etc.)
Packet Length	NMRAH1C2	16	110110111	This gets set to the size of the source data field (in bytes) + 9. This is 439 bytes.
Time	NMRAH1C3	48	Varies	Defines the time that the acquisition of the data within the packet was initiated. 4 bytes of seconds followed by 2 bytes of fractional seconds.
PUS Version	NMRDH1C5	3	000	EID-A Specified, Science data
Checksum Flag	NMRDH1C6	1	0	EID-A Mandatory
Spare	NMRDH1C7	4	0000	EID-A Mandatory
Packet Type	NMRDH1C8	8	00010100	EID-A Specified, Science Data Transfer = 20
Packet Subtype	NMRDH1C9	8	00000011	EID-A Specified, RTU Interface = 3
Pad	NMRDH1C0	8	00000000	EID-A Specified
Source Data		3440	430 bytes	Detailed definition on following page

**Miscellaneous Science Source Data Definition**

Data Element	Size (bits)	Value (binary)	Comment
Operational mode	16		MIRO operational mode
Science data type	8	00000100	Miscellaneous science data = 4
Mirror location	8		1=sky, 2=hot, 3=cold
Reserved	48		Header reserved area
Asteroid Mode Programmed	16	0 or 1	0=Asteroid mode not currently programmed, 1=Asteroid mode programmed
Asteroid Mode Start Time	32	Varies	Spacecraft time for asteroid mode execution to start
Millimeter Subtraction Value	16	Varies	Unsigned integer subtracted from each sub-millimeter sample. As specified in the TC parameter.
Sub-Millimeter Subtraction Value	16	Varies	Unsigned integer subtracted from each millimeter sample. As specified in the TC parameter.
CTS Run Time	40	Varies	ASCII representation of floating point: i.e. 4.878
Continuum / CTS Unloading Gap	40	Varies	ASCII representation of floating point value: i.e. 0.056
CTS Table 1 Midpoint #1	48	Varies	ASCII representation of floating point value: i.e. 125.07
CTS Table 1 Midpoint #2	48	Varies	ASCII representation of floating point value: i.e. 125.08
CTS Table 2 Midpoint #1	48	Varies	ASCII representation of floating point value: i.e. 125.09
CTS Table 2 Midpoint #2	48	Varies	ASCII representation of floating point value: i.e. 125.10
CTS Table 3 Midpoint #1	48	Varies	ASCII representation of floating point value: i.e. 125.11
CTS Table 3 Midpoint #2	48	Varies	ASCII representation of floating point value: i.e. 125.12
CTS Table 4 Midpoint #1	48	Varies	ASCII representation of floating point value: i.e. 125.13
CTS Table 4 Midpoint #2	48	Varies	ASCII representation of floating point value: i.e. 125.14
CTS Calibration band #1 MSB	8	Varies	Valid setting is in the range of 11-31
CTS Calibration band #2 MSB	8	Varies	Valid setting is in the range of 11-31
CTS Calibration band #3 MSB	8	Varies	Valid setting is in the range of 11-31
CTS Calibration band #4 MSB	8	Varies	Valid setting is in the range of 11-31
CTS Calibration band #5 MSB	8	Varies	Valid setting is in the range of 11-31
CTS Calibration band #6 MSB	8	Varies	Valid setting is in the range of 11-31
CTS Calibration band #7 MSB	8	Varies	Valid setting is in the range of 11-31
CTS Nominal band #1 MSB	8	Varies	Valid setting is in the range of 11-31
CTS Nominal band #2 MSB	8	Varies	Valid setting is in the range of 11-31
CTS Nominal band #3 MSB	8	Varies	Valid setting is in the range of 11-31
CTS Nominal band #4 MSB	8	Varies	Valid setting is in the range of 11-31
CTS Nominal band #5 MSB	8	Varies	Valid setting is in the range of 11-31
CTS Nominal band #6 MSB	8	Varies	Valid setting is in the range of 11-31
CTS Nominal band #7 MSB	8	Varies	Valid setting is in the range of 11-31
PLL Lock Successful Counter	32	Varies	The number of times that all 6 PLL lock indicator bits were found to be in lock when a CTS scan was about to be started.
PLL Lock Unsuccessful Counter	32	Varies	The number of times that one or more of the 6 PLL lock indicator bits were found to not be in lock when a CTS scan was about to be started.
Reserved	2640	330 bytes	Will use as required

### 7.1.6.3 Expected Value

Three **[two?]** samples of Miscellaneous Science files are given below.

```
*** Record #27  time =    1171396.767
    OpMode = x2000  MirPos = 1
    AstMode = 0 Ast.Start =          0.000
    MM Subtract =      0  SMM Subtract =      0
    CTS RunTime = 4.956  Unload Gap = 10.00
    CTS Midpoints:
    126.6 123.5 126.2 127.6 124.4 123.9 125.6 126.1
    CTS Cal.band MSBs:  0 0 0 0 0 0 0
    CTS Nom.band MSBs: 11 11 11 11 11 11 11
    PLL Lock:  Success = 2694  Unsuccessful = 268

*** Record #28  time =    1171452.417
    OpMode = x2000  MirPos = 3
    AstMode = 0 Ast.Start =          0.000
    MM Subtract =      0  SMM Subtract =      0
    CTS RunTime = 4.956  Unload Gap = 0.105
    CTS Midpoints:
    126.6 123.5 126.2 127.6 124.4 123.9 125.6 126.1
    CTS Cal.band MSBs: 29 25 25 25 25 25 25
    CTS Nom.band MSBs: 21 17 17 17 17 17 17
    PLL Lock:  Success = 2704  Unsuccessful = 268
```

### 7.1.6.4 RSDB Entries

The Spectroscopic data file YMR00011. Some of the header values are called specifically with NMR..... designations. These are indicated in the above tables.

## 7.1.7 MEMORY DUMP TELEMETRY

### 7.1.7.1 Description

On receipt of a dump request, the defined area of memory is formatted as a dump telemetry report and transferred to the spacecraft.

### 7.1.7.2 Packet Definition

#### Memory Dump Telemetry Definition

Data Element	RSDB Name	Size (bits)	Value (binary)	Comment
Version Number		3	000	EID-A Mandatory
Type		1	0	EID-A Mandatory
Data Field Header Flag		1	1	EID-A Mandatory
Application Process ID		7	1000111	EID-A Specified, 71
Packet Category		4	1001	EID-A Specified, Private (dump) = 9
Sequence Flags	NMRDH191	2	11	EID-A Mandatory
Sequence Count	NMRDH192	14	000 + 1 up counter	First 3 bits are zero indicating 'Ground' as the source. The remaining 11 bits are zero initially, and constitute a one-up Telecommand counter. A separate counter is used for each APID/Packet Category combination.
Packet Length	NMRAH192	16	Varies	This gets set to the size of the source data field (in bytes) + 9.
Time	NMRAH193	48	Varies	Defines the time that the acquisition of the data within the packet was initiated. 4 bytes of seconds followed by 2 bytes of fractional seconds.
PUS Version	NMRDH195	3	010	EID-A Specified
Checksum Flag	NMRDH196	1	0	EID-A Mandatory
Spare	NMRDH197	4	0000	EID-A Mandatory
Packet Type	NMRDH198	8	00000110	EID-A Specified, Memory Management = 6
Packet Subtype	NMRDH199	8	00000110	EID-A Specified, 6 = Memory Dump
Pad	NMRDH190	8	Variable	Copied from TC.
Source Data		Varies	Variable	Detailed definition on following page

#### Memory Dump Telemetry Source Data Definition

Data Element	RSDB Name	Size (bits)	Value (binary)	Comment
Memory ID	NMRDST50	8	01100100	100 = MIROs assigned ID
Number of blocks	NMRDST55	8	00000001	Must be 1.
Start address	NMRAST51	32	Variable	Copied from TC.
Block Length	NMRAST52	16	Variable	Copied from TC.
Data Block	NMRAST53	Varies	Variable	Contents of dump as requested in the memory dump TC.

**7.1.7.3 Expected Value**

Contains the contents of the memory block being dumped, contiguously from the defined address. The block consists of a structured array of memory words, as shown below, repeated a “block\_length” number of times.

For 16 bit word memory width:

Data word
2 octets
Unsigned integer

For 32 bit memory width:

Most significant word	Least significant word
2 octets	2 octets

**7.1.7.4 RSDB Entries**

Telemetry Packet: YMR00007 – Memory Dump MID 100

Telemetry Parameters: In table above

Telemetry Parameters with subparameters are given below.

**NMRAH191 – MR71/9 PckSeqCount**

NMRDH191 Segmentation Flag  
NMRDH192 MR71/9 SourceSeqCount

**NMRAH 193 – MR71/9 DataFieldHdr time**

NMRDH193 MIRO 71/9 Coarse time  
NMRDH194 MIRO 71/9 Fine time

**NMRAH194 – MR71/9 DataFieldHdr PUS**

NMRDH195 PUS version number  
NMRDH196 Checksum flag  
NMRDH197 Data field header spare  
NMRDH198 MIRO 71/9 Packet Type  
NMRDH199 MR 71/9 Packet Subtype  
NMRDH190 Data field header pad

**NMRAST50 – Memory ID Blocks**

NMRDST50 Memory ID  
NMRDST55 Memory Blocks

## 7.1.8 MEMORY CHECKSUM TELEMTRY

### 7.1.8.1 Description

On receipt of a checksum request, the checksum of the contents of the defined area of memory is calculated.

### 7.1.8.2 Packet Definition

#### Memory Checksum Telemetry Definition

Data Element	RSDB Name	Size (bits)	Value (binary)	Comment
Version Number		3	000	EID-A Mandatory
Type		1	0	EID-A Mandatory
Data Field Header Flag		1	1	EID-A Mandatory
Application Process ID		7	1000111	EID-A Specified, 71
Packet Category		4	0111	EID-A Specified, Private (event) = 7
Sequence Flags	NMRDH171	2	11	EID-A Mandatory
Sequence Count	NMRDH172	14	000 + 1 up counter	First 3 bits are zero indicating 'Ground' as the source. The remaining 11 bits are zero initially, and constitute a one-up Telecommand counter. A separate counter is used for each APID/Packet Category combination.
Packet Length	NMRAH172	16	0000000000010011	This gets set to the size of the source data field (in bytes) + 9. In this case, 19.
Time	NMRAH173	48	Varies	Defines the time that the acquisition of the data within the packet was initiated. 4 bytes of seconds followed by 2 bytes of fractional seconds.
PUS Version	NMRDH175	3	010	EID-A Specified
Checksum Flag	NMRDH176	1	0	EID-A Mandatory
Spare	NMRDH177	4	0000	EID-A Mandatory
Packet Type	NMRDH178	8	00000110	EID-A Specified, Memory Management = 6
Packet Subtype	NMRDH179	8	00001010	EID-A Specified, 10 = Memory Check Report
Pad	NMRDH170	8	Variable	Copied from TC.
Source Data		80	Variable	Detailed definition on following page

#### Memory Checksum Telemetry Source Data Definition

Data Element	RSDB Name	Size (bits)	Value (binary)	Comment
Memory ID	NMAST50	8	01100100	100 = MIRO's assigned ID
Number of blocks	NMAST50	8	00000001	Must be 1.
Start address	NMAST51	32	Variable	Copied from TC.
Block Length	NMAST52	16	Variable	Copied from TC.
Checksum	NMAST54	16	Variable	Checksum computed by ESA standard checksum algorithm.

### 7.1.8.3 Expected Value

Typical output file is shown below.

Time	(Pkt Typ, STyp)	Data
1143409.69735	( 6,10)	6401 ff80
		0000 8000
		de39 0000

Miro makes use of a standard ESA CRC computation algorithm/routine. This routine is used to compute the CRC's on incoming telecommand packets and also for computation of the memory checksum that takes place as part of the memory check service. The memory check can be performed on both the RAM and EEPROM areas of memory. The code is as follows:

```

UINT16 calccrc_( UINT8 *buffer, unsigned count )
{
  UINT16 crc = 0xffff;
  unsigned i;
  unsigned j;
  UINT16 wtemp;
  char audit_string[80];

  for( i = 0; i < count; i++ )
  {
    wtemp = buffer[i] << 8;
    for( j = 0; j < 8; j++ )
    {
      if( (crc ^ wtemp) & 0x8000 )
        crc = (crc << 1) ^ 0x1021;
      else
        crc = (crc << 1);
      wtemp = (wtemp << 1);
    }
  }
  return( crc );
}

```

When the code is executing and performing a checksum on regular memory (RAM) it proceeds through a byte at a time and the checksum is valid because the RAM is byte addressable. The EEPROM on the other hand is quadword addressable rather than byte addressable.

The calccrc routine accesses memory one byte at a time, as each byte is then processed individually within the routine. Accessing EEPROM memory via byte accesses produces incorrect data 50% of the time. The following example illustrates the problem. Suppose the first quadword of EEPROM located at 0xFF800000 contained the value 0xAABBCCDD. If one were to read the following memory locations via byte accesses to locations 0xFF800000, 0xFF800001, 0xFF800002 and 0xFF800003 one would get 0xAA, 0xAA, 0xDD



and 0xDD respectively. Craig Hatfield obtained these results by running code on a flight rad6000.

#### 7.1.8.4 RSDB Entries

Telemetry Packet: YMR00008 – Memory Check MID 100

Telemetry Parameters: In table above

Telemetry Parameters with subparts are given below

##### **NMRAH171 – MR71/7 PcktSeqCount**

NMRDH171 Segmentation Flag  
NMRDH172 MR 71/7 SourceSeqCount

##### **NMRAH173 – MR71/7 DataFieldHdr time**

NMRDH173 MIRO 71/7 Coarse time  
NMRDH174 MIRO 71/7 Fine time

##### **NMRAH174 – MR71/7 DataFieldHdr PUS**

NMRDH175 PUS version number  
NMRDH176 Checksum flag  
NMRDH177 Data field header spare  
NMRDH178 MIRO 71/7 Packet Type  
NMRDH179 MIRO 71/7 Packet Subtype  
NMRDH170 Data field header pad

## 7.1.9 MIRO ON (PROGRESS EVENT REPORT #1) TELEMETRY

### 7.1.9.1 Description

The MIRO On progress event report is generated when the MIRO flight software has come up normally and received a time synchronization TC packet and the associated TSY pulse from the spacecraft.

### 7.1.9.2 Packet Definition

Data Element	RSDB Name	Size (bits)	Value (binary)	Comment
Version Number		3	000	EID-A Mandatory
Type		1	0	EID-A Mandatory
Data Field Header Flag		1	1	EID-A Mandatory
Application Process ID		7	1000111	EID-A Specified, 71
Packet Category		4	111	EID-A Specified, Event = 7
Segmentation Flags		2	11	EID-A Mandatory
Source Sequence Count	NMRDH171	14	1 up counter	Zero initially, A separate counter is used for each APID/Packet Category combination (i.e. science, housekeeping, memory dump, etc.)
Packet Length	NMRDH172	16	0000000000001011	This gets set to the size of the source data field (in bytes) + 9. This is 11 bytes.
Time	NMRAH172	48	Varies	Defines the time that the acquisition of the data within the packet was initiated. 4 bytes of seconds followed by 2 bytes of fractional seconds.
PUS Version	NMRAH173	3	010	EID-A Specified, Non-Science data
Checksum Flag	NMRDH175	1	0	EID-A Mandatory
Spare	NMRDH176	4	0000	EID-A Mandatory
Packet Type	NMRDH177	8	00000101	EID-A Specified, Event = 5
Packet Subtype	NMRDH178	8	00000011	EID-A Specified, Normal/Progress Report = 1
Pad	NMRDH179	8	00000000	EID-A Specified
Source Data	NMRDH170	16	2 bytes	Detailed definition on following page

### MIRO On (Progress Event Report #1) Source Data Definition

Data Element	RSDB Name	Size (bits)	Value (binary)	Comment
Event ID (EID)	NMRA0EID	16	1010011111111110	MIRO range given in EID-A 2.8. This one is 43006. This is generated when the flight software has come up normally and received a time synchronization TC packet and the associated TSY pulse from the spacecraft. Basically when we synch to spacecraft time for the first time.

**7.1.9.3 Expected Value**

A typical output is shown below.

Time	(Pkt Typ, STyp)	Data
1139979.86552	( 5, 1)	a7fe 0000 (note that a7fe(HEX) = 43006(DEC))

**7.1.9.4 RSDB Entries**

Telemetry Packet: YMR00012 – Progress Event 1

Telemetry Parameter: In table above

Telemetry Parameters with subparts are given below

**NMRAH171 – MR71/7 PcktSeqCount**

NMRDH171	Segmentation Flag
NMRDH172	MR 71/7 SourceSeqCount

**NMRAH173 – MR71/7 DataFieldHdr time**

NMRDH173	MIRO 71/7 Coarse time
NMRDH174	MIRO 71/7 Fine time

**NMRAH174 – MR71/7 DataFieldHdr PUS**

NMRDH175	PUS version number
NMRDH176	Checksum flag
NMRDH177	Data field header spare
NMRDH178	MIRO 71/7 Packet Type
NMRDH179	MIRO 71/7 Packet Subtype
NMRDH170	Data field header pad

## 7.1.10 ASTEROID MODE STARTED (PROGRESS EVENT REPORT #2) TELEMETRY

### 7.1.10.1 Description

This asteroid mode started report is generated when the flight software begins running the asteroid mode sequence. This should correlate to the asteroid mode start time issued in the asteroid mode TC.

### 7.1.10.2 Packet Definition

Data Element	RSDB Name	Size (bits)	Value (binary)	Comment
Version Number		3	000	EID-A Mandatory
Type		1	0	EID-A Mandatory
Data Field Header Flag		1	1	EID-A Mandatory
Application Process ID		7	1000111	EID-A Specified, 71
Packet Category		4	111	EID-A Specified, Event = 7
Segmentation Flags		2	11	EID-A Mandatory
Source Sequence Count	NMRDH171	14	1 up counter	Zero initially, A separate counter is used for each APID/Packet Category combination (i.e. science, housekeeping, memory dump, etc.)
Packet Length	NMRDH172	16	0000000000001011	This gets set to the size of the source data field (in bytes) + 9. This is 11 bytes.
Time	NMRAH172	48	Varies	Defines the time that the acquisition of the data within the packet was initiated. 4 bytes of seconds followed by 2 bytes of fractional seconds.
PUS Version	NMRAH173	3	010	EID-A Specified, Non-Science data
Checksum Flag	NMRDH175	1	0	EID-A Mandatory
Spare	NMRDH176	4	0000	EID-A Mandatory
Packet Type	NMRDH177	8	00000101	EID-A Specified, Event = 5
Packet Subtype	NMRDH178	8	00000011	EID-A Specified, Normal/Progress Report = 1
Pad	NMRDH179	8	00000000	EID-A Specified
Source Data	NMRDH170	16	2 bytes	Detailed definition on following page

### Asteroid Mode Started (Progress Event Report #2) Source Data Definition

Data Element	RSDB Name	Size (bits)	Value (binary)	Comment
Event ID (EID)	NMRA0EID	16	1010011111111111	MIRO range given in EID-A 2.8. This one is 43007. This is generated when the flight software begins running the asteroid mode sequence. This should correlate to the asteroid mode start time issued in the asteroid mode TC.

**7.1.10.3 Expected Value**

A typical output is shown below.

Time	(Pkt Typ, STyp)	Data
1139979.86552	( 5, 1)	a7ff 0000 (note that a7ff(HEX) = 43007(DEC))

**7.1.10.4 RSDB Entries**

Telemetry Packet: YMR00013 – Progress Event 2

Telemetry Parameter: In table above

Telemetry Parameters with subparts are given below

**NMRAH171 – MR71/7 PcktSeqCount**

NMRDH171	Segmentation Flag
NMRDH172	MR 71/7 SourceSeqCount

**NMRAH173 – MR71/7 DataFieldHdr time**

NMRDH173	MIRO 71/7 Coarse time
NMRDH174	MIRO 71/7 Fine time

**NMRAH174 – MR71/7 DataFieldHdr PUS**

NMRDH175	PUS version number
NMRDH176	Checksum flag
NMRDH177	Data field header spare
NMRDH178	MIRO 71/7 Packet Type
NMRDH179	MIRO 71/7 Packet Subtype
NMRDH170	Data field header pad

## 7.1.11 ASTEROID MODE COMPLETED (PROGRESS EVENT REPORT #3) TELEMETRY

### 7.1.11.1 Description

This asteroid mode completed report is generated when the flight software completes the asteroid mode sequence.

### 7.1.11.2 Packet Definition

Data Element	RSDB Name	Size (bits)	Value (binary)	Comment
Version Number		3	000	EID-A Mandatory
Type		1	0	EID-A Mandatory
Data Field Header Flag		1	1	EID-A Mandatory
Application Process ID		7	1000111	EID-A Specified, 71
Packet Category		4	111	EID-A Specified, Event = 7
Segmentation Flags		2	11	EID-A Mandatory
Source Sequence Count	NMRDH171	14	1 up counter	Zero initially, A separate counter is used for each APID/Packet Category combination (i.e. science, housekeeping, memory dump, etc.)
Packet Length	NMRDH172	16	0000000000001011	This gets set to the size of the source data field (in bytes) + 9. This is 11 bytes.
Time	NMRAH172	48	Varies	Defines the time that the acquisition of the data within the packet was initiated. 4 bytes of seconds followed by 2 bytes of fractional seconds.
PUS Version	NMRAH173	3	010	EID-A Specified, Non-Science data
Checksum Flag	NMRDH175	1	0	EID-A Mandatory
Spare	NMRDH176	4	0000	EID-A Mandatory
Packet Type	NMRDH177	8	00000101	EID-A Specified, Event = 5
Packet Subtype	NMRDH178	8	00000011	EID-A Specified, Normal/Progress Report = 1
Pad	NMRDH179	8	00000000	EID-A Specified
Source Data	NMRDH170	16	2 bytes	Detailed definition on following page

### Asteroid Mode Completed (Progress Event Report #3) Source Data Definition

Data Element	RSDB Name	Size (bits)	Value (binary)	Comment
Event ID (EID)	NMRA0EID	16	1010100000000000	MIRO range given in EID-A 2.8. This one is 43008. This is generated when the flight software completes the asteroid mode sequence.

**7.1.11.3 Expected Value**

A typical output is shown below.

Time	(Pkt Typ, STyp)	Data
1139979.86552	( 5, 1)	a800 0000 (note that a800(HEX) = 43008(DEC))

**7.1.11.4 RSDB Entries**

Telemetry Packet: YMR00014 – Progress Event 3

Telemetry parameters: In table above

Telemetry Parameters with subparts are given below

**NMRAH171 – MR71/7 PcktSeqCount**

NMRDH171	Segmentation Flag
NMRDH172	MR 71/7 SourceSeqCount

**NMRAH173 – MR71/7 DataFieldHdr time**

NMRDH173	MIRO 71/7 Coarse time
NMRDH174	MIRO 71/7 Fine time

**NMRAH174 – MR71/7 DataFieldHdr PUS**

NMRDH175	PUS version number
NMRDH176	Checksum flag
NMRDH177	Data field header spare
NMRDH178	MIRO 71/7 Packet Type
NMRDH179	MIRO 71/7 Packet Subtype
NMRDH170	Data field header pad

## 7.1.12 CONNECTION REPORT TELEMETRY

### 7.1.12.1 Description

Upon receipt of a connection test request, the connection test report is generated if the following was completed successfully after start-up.

1. Mirror driven to mechanical stop.
2. Mirror moved successfully to space position.
3. Time synch received or 60 seconds pass, whichever is first.
4. MIRO turned on housekeeping telemetry collection.

### 7.1.12.2 Telemetry Definition

Data Element	RSDB Name	Size (bits)	Value (binary)	Comment
Version Number		3	000	EID-A Mandatory
Type		1	0	EID-A Mandatory
Data Field Header Flag		1	1	EID-A Mandatory
Application Process ID		7	1000111	EID-A Specified, 71
Packet Category		4	0111	EID-A Specified, Private (event) = 7
Sequence Flags	NMRDH171	2	11	EID-A Mandatory
Sequence Count	NMRDH172	14	000 + 1 up counter	First 3 bits are zero indicating 'Ground' as the source. The remaining 11 bits are zero initially, and constitute a one-up Telecommand counter. A separate counter is used for each APID/Packet Category combination.
Packet Length	NMRAH172	16	000000000010011	This gets set to the size of the source data field (in bytes) + 9. In this case, 19.
Time	NMRAH173	48	Varies	Defines the time that the acquisition of the data within the packet was initiated. 4 bytes of seconds followed by 2 bytes of fractional seconds.
PUS Version	NMRDH175	3	010	EID-A Specified
Checksum Flag	NMRDH176	1	0	EID-A Mandatory
Spare	NMRDH177	4	0000	EID-A Mandatory
Packet Type	NMRDH178	8	00000110	EID-A Specified, Connection Test Report=17
Packet Subtype	NMRDH179	8	00001010	EID-A Specified, 2 = Connection Test Report
Pad	NMRDH170	8	Variable	Copied from TC.
Source Data			Variable	0000 0000



**7.1.12.3 Expected value**

The expected output for this report is below

Time	(Pkt Typ, STyp)	Data
1139983.43179	(17, 2)	0000 0000

**7.1.12.4 RSDB Entries**

Telemetry Packet: YMR00009 - Connection Report

Telemetry Parameters are given in the table above

Telemetry Parameters with subparts are given below

**NMRAH171 – MR71/7 PcktSeqCount**

NMRDH171	Segmentation Flag
NMRDH172	MR 71/7 SourceSeqCount

**NMRAH173 – MR71/7 DataFieldHdr time**

NMRDH173	MIRO 71/7 Coarse time
NMRDH174	MIRO 71/7Fine time

**NMRAH174 – MR71/7 DataFieldHdr PUS**

NMRDH175	PUS version number
NMRDH176	Checksum flag
NMRDH177	Data field header spare
NMRDH178	MIRO 71/7 Packet Type
NMRDH179	MIRO 71/7 Packet Subtype
NMRDH170	Data field header pad

## 7.1.13 MIRROR ERROR REPORT TYPE 1 TELEMETRY

### 7.1.13.1 Description

This mirror error report is generated when the mirror fails to achieve the desired position, but then is successfully driven back and then positioned at the space position.

### 7.1.13.2 Packet Definition

Data Element	RSDB Name	Size (bits)	Value (binary)	Comment
Version Number		3	000	EID-A Mandatory
Type		1	0	EID-A Mandatory
Data Field Header Flag		1	1	EID-A Mandatory
Application Process ID		7	1000111	EID-A Specified, 71
Packet Category		4	111	EID-A Specified, Event = 7
Segmentation Flags	NMRDH171	2	11	EID-A Mandatory
Source Sequence Count	NMRDH172	14	1 up counter	Zero initially, A separate counter is used for each APID/Packet Category combination (i.e. science, housekeeping, memory dump, etc.)
Packet Length	NMRAH172	16	0000000000001101	This gets set to the size of the source data field (in bytes) + 9. This is 13 bytes.
Time	NMRAH173	48	Varies	Defines the time that the acquisition of the data within the packet was initiated. 4 bytes of seconds followed by 2 bytes of fractional seconds.
PUS Version	NMRDH175	3	010	EID-A Specified, Non-Science data
Checksum Flag	NMRDH176	1	0	EID-A Mandatory
Spare	NMRDH177	4	0000	EID-A Mandatory
Packet Type	NMRDH178	8	00000101	EID-A Specified, Event = 5
Packet Subtype	NMRDH179	8	00000010	EID-A Specified, Warning = 2
Pad	NMRDH170	8	00000000	EID-A Specified
Source Data		32	4 bytes	Detailed definition on following page

### Mirror Error Type #1 Source Data Definition

Data Element	RSDB Name	Size (bits)	Value (binary)	Comment
Event ID (EID)	NMRA0EID	16	1010011111111001	MIRO range given in EID-A 2.8. This one is 43001. This is generated when the mirror fails to achieve the desired position, but then is successfully driven back then positioned at space.
Failed Position	NMRA0063	16	1, 2 or 3	The position that the mirror could not achieve. 1=space, 2=hot, 3=cold

**7.1.13.3 Expected Values**

A typical output is shown below.

Time	(Pkt Typ, STyp)	Data
1139979.86552	( 5,2 )	a7f9 0000 (note that a7f9(HEX) = 43001(DEC)) 0000 0001

**7.1.13.4 RSDB Entries**

Telemetry Packet: YMR00002 – Mirror Error Type 1

Telemetry Parameter: Identified in table above.

Telemetry Parameters with subparts are given below

**NMRAH171 – MR71/7 PcktSeqCount**

NMRDH171	Segmentation Flag
NMRDH172	MR 71/7 SourceSeqCount

**NMRAH173 – MR71/7 DataFieldHdr time**

NMRDH173	MIRO 71/7 Coarse time
NMRDH174	MIRO 71/7 Fine time

**NMRAH174 – MR71/7 DataFieldHdr PUS**

NMRDH175	PUS version number
NMRDH176	Checksum flag
NMRDH177	Data field header spare
NMRDH178	MIRO 71/7 Packet Type
NMRDH179	MIRO 71/7 Packet Subtype
NMRDH170	Data field header pad

## 7.1.14 MIRROR ERROR REPORT TYPE 2 TELEMETRY

### 7.1.14.1 Description

This mirror error report is generated when the mirror fails to achieve the desired position, is then driven back and then fails to find the space position.

### 7.1.14.2 Packet Definition

Data Element	RSDB Name	Size (bits)	Value (binary)	Comment
Version Number		3	000	EID-A Mandatory
Type		1	0	EID-A Mandatory
Data Field Header Flag		1	1	EID-A Mandatory
Application Process ID		7	1000111	EID-A Specified, 71
Packet Category		4	111	EID-A Specified, Event = 7
Segmentation Flags	NMRDH171	2	11	EID-A Mandatory
Source Sequence Count	NMRDH172	14	1 up counter	Zero initially, A separate counter is used for each APID/Packet Category combination (i.e. science, housekeeping, memory dump, etc.)
Packet Length	NMRAH172	16	0000000000001101	This gets set to the size of the source data field (in bytes) + 9. This is 13 bytes.
Time	NMRAH173	48	Varies	Defines the time that the acquisition of the data within the packet was initiated. 4 bytes of seconds followed by 2 bytes of fractional seconds.
PUS Version	NMRDH175	3	010	EID-A Specified, Non-Science data
Checksum Flag	NMRDH176	1	0	EID-A Mandatory
Spare	NMRDH177	4	0000	EID-A Mandatory
Packet Type	NMRDH178	8	00000101	EID-A Specified, Event = 5
Packet Subtype	NMRDH179	8	00000010	EID-A Specified, Warning = 2
Pad	NMRDH170	8	00000000	EID-A Specified
Source Data		32	4 bytes	Detailed definition on following page

### Mirror Error Type #2 Source Data Definition

Data Element	RSDB Name	Size (bits)	Value (binary)	Comment
Event ID (EID)	NMRA0EID	16	1010011111111010	MIRO range given in EID-A 2.8. This one is 43002. This is generated when the mirror fails to achieve the desired position, is then driven back and then fails to find the space position.
Failed Position	NMRA0063	16	1, 2 or 3	The position that the mirror could not achieve. 1=space, 2=hot, 3=cold

**7.1.14.3 Expected Value**

A typical output is shown below.

Time	(Pkt Typ, STyp)	Data
1139979.86552	( 5,2 )	a7fa 0000 (note that a7fa(HEX) = 43002(DEC)) 0000 0001

**7.1.14.4 RSDB Entries**

Telemetry Packet: YMR00003 – Mirror Type 2

Telemetry Parameters: In table above

Telemetry Parameters with subparts are given below

**NMRAH171 – MR71/7 PcktSeqCount**

NMRDH171	Segmentation Flag
NMRDH172	MR 71/7 SourceSeqCount

**NMRAH173 – MR71/7 DataFieldHdr time**

NMRDH173	MIRO 71/7 Coarse time
NMRDH174	MIRO 71/7 Fine time

**NMRAH174 – MR71/7 DataFieldHdr PUS**

NMRDH175	PUS version number
NMRDH176	Checksum flag
NMRDH177	Data field header spare
NMRDH178	MIRO 71/7 Packet Type
NMRDH179	MIRO 71/7 Packet Subtype
NMRDH170	Data field header pad

## 7.1.15 MIRROR ERROR REPORT TYPE 3 TELEMETRY

### 7.1.15.1 Description

This mirror error report is generated when the mirror fails to achieve the desired position, is then driven back and then fails to find the space position, the pin puller is activated and the space position located.

### 7.1.15.2 Packet Definition

Data Element	RSDB Name	Size (bits)	Value (binary)	Comment
Version Number		3	000	EID-A Mandatory
Type		1	0	EID-A Mandatory
Data Field Header Flag		1	1	EID-A Mandatory
Application Process ID		7	1000111	EID-A Specified, 71
Packet Category		4	111	EID-A Specified, Event = 7
Segmentation Flags		2	11	EID-A Mandatory
Source Sequence Count	NMRDH171	14	1 up counter	Zero initially, A separate counter is used for each APID/Packet Category combination (i.e. science, housekeeping, memory dump, etc.)
Packet Length	NMRDH172	16	0000000000001011	This gets set to the size of the source data field (in bytes) + 9. This is 11 bytes.
Time	NMRAH172	48	Varies	Defines the time that the acquisition of the data within the packet was initiated. 4 bytes of seconds followed by 2 bytes of fractional seconds.
PUS Version	NMRAH173	3	010	EID-A Specified, Non-Science data
Checksum Flag	NMRDH175	1	0	EID-A Mandatory
Spare	NMRDH176	4	0000	EID-A Mandatory
Packet Type	NMRDH177	8	00000101	EID-A Specified, Event = 5
Packet Subtype	NMRDH178	8	00000010	EID-A Specified, Warning = 2
Pad	NMRDH179	8	00000000	EID-A Specified
Source Data	NMRDH170	16	2 bytes	Detailed definition on following page

### Mirror Error Type #3 Source Data Definition

Data Element	RSDB Name	Size (bits)	Value (binary)	Comment
Event ID (EID)	NMRA0EID	16	101001111111011	MIRO range given in EID-A 2.8. This one is 43003. This is generated when the mirror fails to achieve the desired position, is then driven back and then fails to find the space position, the pin puller is activated and the space position located.

**7.1.15.3 Expected Value**

A typical output is shown below.

Time	(Pkt Typ, STyp)	Data
1139979.86552	( 5,2 )	a7fb 0000 (note that a7fb(HEX) = 43003(DEC))

**7.1.15.4 RSDB Entries**

Telemetry Packet: YMR00004 – Mirror Error Type 3

Telemetry Parameter: In table above

Telemetry Parameters with subparts are given below

**NMRAH171 – MR71/7 PcktSeqCount**

NMRDH171	Segmentation Flag
NMRDH172	MR 71/7 SourceSeqCount

**NMRAH173 – MR71/7 DataFieldHdr time**

NMRDH173	MIRO 71/7 Coarse time
NMRDH174	MIRO 71/7 Fine time

**NMRAH174 – MR71/7 DataFieldHdr PUS**

NMRDH175	PUS version number
NMRDH176	Checksum flag
NMRDH177	Data field header spare
NMRDH178	MIRO 71/7 Packet Type
NMRDH179	MIRO 71/7 Packet Subtype
NMRDH170	Data field header pad

## 7.1.16 MIRROR ERROR REPORT TYPE 4 TELEMETRY

### 7.1.16.1 Description

This mirror error command is generated when the mirror fails to achieve the desired position, is then driven back and then fails to find the space position, the pin puller is activated and the space position is not located.

### 7.1.16.2 Packet Definition

Data Element	RSDB Name	Size (bits)	Value (binary)	Comment
Version Number		3	000	EID-A Mandatory
Type		1	0	EID-A Mandatory
Data Field Header Flag		1	1	EID-A Mandatory
Application Process ID		7	1000111	EID-A Specified, 71
Packet Category		4	111	EID-A Specified, Event = 7
Segmentation Flags		2	11	EID-A Mandatory
Source Sequence Count	NMRDH171	14	1 up counter	Zero initially, A separate counter is used for each APID/Packet Category combination (i.e. science, housekeeping, memory dump, etc.)
Packet Length	NMRDH172	16	0000000000001011	This gets set to the size of the source data field (in bytes) + 9. This is 11 bytes.
Time	NMRAH172	48	Varies	Defines the time that the acquisition of the data within the packet was initiated. 4 bytes of seconds followed by 2 bytes of fractional seconds.
PUS Version	NMRAH173	3	010	EID-A Specified, Non-Science data
Checksum Flag	NMRDH175	1	0	EID-A Mandatory
Spare	NMRDH176	4	0000	EID-A Mandatory
Packet Type	NMRDH177	8	00000101	EID-A Specified, Event = 5
Packet Subtype	NMRDH178	8	00000011	EID-A Specified, Ground Action = 3
Pad	NMRDH179	8	00000000	EID-A Specified
Source Data	NMRDH170	16	2 bytes	Detailed definition on following page

### Mirror Error Type #4 Source Data Definition

Data Element	RSDB Name	Size (bits)	Value (binary)	Comment
Event ID (EID)	NMRA0EID	16	1010011111111100	MIRO range given in EID-A 2.8. This one is 43004. This is generated when the mirror fails to achieve the desired position, is then driven back and then fails to find the space position, the pin puller is activated and the space position is not located.



**7.1.16.3 Expected Value**

A typical output is shown below.

Time	(Pkt Typ, STyp)	Data
1139979.86552	( 5,3 )	a7fc 0000 (note that a7fc(HEX) = 43004(DEC))

**7.1.16.4 RSDB Entries**

Telemetry Packet: YMR00005 – Mirror Error Type 4

Telemetry Parameters are given in the tables above.

Telemetry Parameters with subparts are given below

**NMRAH171 – MR71/7 PcktSeqCount**

NMRDH171	Segmentation Flag
NMRDH172	MR 71/7 SourceSeqCount

**NMRAH173 – MR71/7 DataFieldHdr time**

NMRDH173	MIRO 71/7 Coarse time
NMRDH174	MIRO 71/7 Fine time

**NMRAH174 – MR71/7 DataFieldHdr PUS**

NMRDH175	PUS version number
NMRDH176	Checksum flag
NMRDH177	Data field header spare
NMRDH178	MIRO 71/7 Packet Type
NMRDH179	MIRO 71/7 Packet Subtype
NMRDH170	Data field header pad

## 7.1.17 MIRROR ERROR REPORT TYPE 5 TELEMETRY

### 7.1.17.1 Description

This mirror error report is generated when a previous mirror failure was recovered from and was followed by a subsequent failure.

### 7.1.17.2 Packet Definition

Data Element	RSDB Name	Size (bits)	Value (binary)	Comment
Version Number		3	000	EID-A Mandatory
Type		1	0	EID-A Mandatory
Data Field Header Flag		1	1	EID-A Mandatory
Application Process ID		7	1000111	EID-A Specified, 71
Packet Category		4	111	EID-A Specified, Event = 7
Segmentation Flags		2	11	EID-A Mandatory
Source Sequence Count	NMRDH171	14	1 up counter	Zero initially, A separate counter is used for each APID/Packet Category combination (i.e. science, housekeeping, memory dump, etc.)
Packet Length	NMRDH172	16	0000000000001101	This gets set to the size of the source data field (in bytes) + 9. This is 13 bytes.
Time	NMRAH172	48	Varies	Defines the time that the acquisition of the data within the packet was initiated. 4 bytes of seconds followed by 2 bytes of fractional seconds.
PUS Version	NMRAH173	3	010	EID-A Specified, Non-Science data
Checksum Flag	NMRDH175	1	0	EID-A Mandatory
Spare	NMRDH176	4	0000	EID-A Mandatory
Packet Type	NMRDH177	8	00000101	EID-A Specified, Event = 5
Packet Subtype	NMRDH178	8	00000011	EID-A Specified, Ground Action = 3
Pad	NMRDH179	8	00000000	EID-A Specified
Source Data	NMRDH170	32	4 bytes	Detailed definition on following page

### Mirror Error Type #5 Source Data Definition

Data Element	RSDB Name	Size (bits)	Value (binary)	Comment
Event ID (EID)	NMRA0EID	16	1010011111111101	MIRO range given in EID-A 2.8. This one is 43005. This is generated when a previous mirror failure was recovered from and was followed by a subsequent failure.
Failed Position	NMRA0063	16	1, 2 or 3	The position that the mirror could not achieve. 1=space, 2=hot, 3=cold

**7.1.17.3 Expected Value**

A typical output is shown below.

Time	(Pkt Typ, STyp)	Data
1139979.86552	( 5,3 )	a7fd 0000 (note that a7fd(HEX) = 43005(DEC)) 0000 0001

**7.1.17.4 RSDB Entries**

Telemetry Packet: YMR00006 – Mirror Error Type 5

Telemetry Parameters: In table above

Telemetry Parameters with subparts are given below

**NMRAH171 – MR71/7 PcktSeqCount**

NMRDH171	Segmentation Flag
NMRDH172	MR 71/7 SourceSeqCount

**NMRAH173 – MR71/7 DataFieldHdr time**

NMRDH173	MIRO 71/7 Coarse time
NMRDH174	MIRO 71/7 Fine time

**NMRAH174 – MR71/7 DataFieldHdr PUS**

NMRDH175	PUS version number
NMRDH176	Checksum flag
NMRDH177	Data field header spare
NMRDH178	MIRO 71/7 Packet Type
NMRDH179	MIRO 71/7 Packet Subtype
NMRDH170	Data field header pad

## 7.1.18 CTS ERROR REPORT TELEMETRY

### 7.1.18.1 Description

This CTS error report is generated when the CTS busy line is still high when it should already have gone low indicating a scan completion.

### 7.1.18.2 Packet Definition

Data Element	RSDB Name	Size (bits)	Value (binary)	Comment
Version Number		3	000	EID-A Mandatory
Type		1	0	EID-A Mandatory
Data Field Header Flag		1	1	EID-A Mandatory
Application Process ID		7	1000111	EID-A Specified, 71
Packet Category		4	111	EID-A Specified, Event = 7
Segmentation Flags		2	11	EID-A Mandatory
Source Sequence Count	NMRDH171	14	1 up counter	Zero initially, A separate counter is used for each APID/Packet Category combination (i.e. science, housekeeping, memory dump, etc.)
Packet Length	NMRDH172	16	0000000000001011	This gets set to the size of the source data field (in bytes) + 9. This is 11 bytes.
Time	NMRAH172	48	Varies	Defines the time that the acquisition of the data within the packet was initiated. 4 bytes of seconds followed by 2 bytes of fractional seconds.
PUS Version	NMRAH173	3	010	EID-A Specified, Non-Science data
Checksum Flag	NMRDH175	1	0	EID-A Mandatory
Spare	NMRDH176	4	0000	EID-A Mandatory
Packet Type	NMRDH177	8	00000101	EID-A Specified, Event = 5
Packet Subtype	NMRDH178	8	00000011	EID-A Specified, Ground Action = 3
Pad	NMRDH179	8	00000000	EID-A Specified
Source Data	NMRDH170	16	2 bytes	Detailed definition on following page

### CTS Error Source Data Definition

Data Element	RSDB Name	Size (bits)	Value (binary)	Comment
Event ID (EID)	NMRA0EID	16	1010100000000001	MIRO range given in EID-A 2.8. This one is 43009. This is generated when the CTS busy line is still high when it should already have gone low indicating a scan completion.

**7.1.18.3 Expected Value**

A typical output is shown below.

Time	(Pkt Typ, STyp)	Data
1139979.86552	( 5,3 )	a801 0000 (note that a801(HEX) = 43009(DEC))

**7.1.18.4 RSDB Entries**

Telemetry Packet: YMR00015 – CTS Error

Telemetry Parameters: In table above.

Telemetry Parameters with subparts are given below

**NMRAH171 – MR71/7 PcktSeqCount**

NMRDH171	Segmentation Flag
NMRDH172	MR 71/7 SourceSeqCount

**NMRAH173 – MR71/7 DataFieldHdr time**

NMRDH173	MIRO 71/7 Coarse time
NMRDH174	MIRO 71/7 Fine time

**NMRAH174 – MR71/7 DataFieldHdr PUS**

NMRDH175	PUS version number
NMRDH176	Checksum flag
NMRDH177	Data field header spare
NMRDH178	MIRO 71/7 Packet Type
NMRDH179	MIRO 71/7 Packet Subtype
NMRDH170	Data field header pad

## 7.1.19 ACCEPT SUCCESS EVENT REPORT TELEMETRY

### 7.1.19.1 Description

This report is generated when within 4 seconds of successful receipt of a telecommand.

### 7.1.19.2 Packet Definition

Data Element	RSDB Name	Size (bits)	Value (binary)	Comment
Version Number		3		EID-A Mandatory
Type		1		EID-A Mandatory
Data Field Header Flag		1		EID-A Mandatory
Application Process ID		7		EID-A Specified, 71
Packet Category		4		EID-A Specified, Event = 1
Segmentation Flags	NMRDH111	2		EID-A Mandatory
Source Sequence Count	NMRDH112	14		Zero initially, A separate counter is used for each APID/Packet Category combination (I.e. science, housekeeping, memory dump, etc.)
Packet Length	NMRAH112	16		
Time	NMRAH113	48		Defines the time that the acquisition of the data within the packet was initiated. 4 bytes of seconds followed by 2 bytes of fractional seconds.
PUS Version	NMRDH115	3		EID-A Specified, Non-Science data
Checksum Flag	NMRDH116	1		EID-A Mandatory
Spare	NMRDH117	4		EID-A Mandatory
Packet Type	NMRDH118	8		EID-A Specified, Telecommand Verification = 1
Packet Subtype	NMRDH119	8		EID-A Specified, Acceptance Success Report = 1
Pad	NMRDH110	8		EID-A Specified
Source Data		32		Detailed definition on following page

### Accept Success Event Report Source Data Definition

Data Element	RSDB Name	Size (bits)	Value (binary)	Comment
Global PID	NMRAST01	16		
Sequence Control	NMRAST02	16		

**7.1.19.3 Expected Value**

A typical output is shown below.

Time	(Pkt Typ, STyp)	Data
1139979.86552	( 1,1 )	0000 0000

**7.1.19.4 RSDB Entries**

Telemetry Packet: YMRST001 – Accept Success

Telemetry Parameters: In table above.

Telemetry Parameters that have subparameters are listed below.

**NMRAH111 – PckSeqCount**

NMRDH111	Segmentation Flag
NMRDH112	MR 71/1 SourceSeqCount

**NMRAH113 – DataFieldHdr PUS**

NMRDH113	MIRO 71/1 Coarse time
NMRDH114	MIRO 71/1 Fine time

**NMRAH114 – MR71/1 DataFieldHdr PUS**

NMRDH110	Data field header pad
NMRDH115	PUS version number
NMRDH116	Checksum flag
NMRDH117	Data field header spare
NMRDH118	MIRO 71/1 Packet Type
NMRDH119	MIRO 71/1 Packet Subtype

**NMRAST01 – Global PID**

NMRDST01	PID
NMRDST02	PctCategory

**NMRAST02 – Sequence Counts**

NMRDST03	Source
NMRDST04	Counter

## 7.1.20 INCOMPLETE PACKET EVENT REPORT TELEMETRY

### 7.1.20.1 Description

This report is generated when failed to receive whole packet within time out period (2 seconds for OBDH bus).

### 7.1.20.2 Packet Definition

Data Element	RSDB Name	Size (bits)	Value (binary)	Comment
Version Number		3		EID-A Mandatory
Type		1		EID-A Mandatory
Data Field Header Flag		1		EID-A Mandatory
Application Process ID		7		EID-A Specified, 71
Packet Category		4		EID-A Specified, Event = 1
Segmentation Flags	NMRDH111	2		EID-A Mandatory
Source Sequence Count	NMRDH112	14		Zero initially, A separate counter is used for each APID/Packet Category combination (i.e. science, housekeeping, memory dump, etc.)
Packet Length	NMRAH112	16		
Time	NMRAH113	48		Defines the time that the acquisition of the data within the packet was initiated. 4 bytes of seconds followed by 2 bytes of fractional seconds.
PUS Version	NMRDH115	3		EID-A Specified, Non-Science data
Checksum Flag	NMRDH116	1		EID-A Mandatory
Spare	NMRDH117	4		EID-A Mandatory
Packet Type	NMRDH118	8		EID-A Specified, Telecommand Verification = 1
Packet Subtype	NMRDH119	8		EID-A Specified, Acceptance Failure = 2
Pad	NMRDH110	8		EID-A Specified
Source Data		16		Detailed definition on following page

### Incomplete Packet Event Report Source Data Definition

Data Element	RSDB Name	Size (bits)	Value (binary)	Comment
Global PID	NMRAST01	16		
Sequence Control	NMRAST02	16		
Failure Code	NMRAST03	16	1	
Packet Service Info	NMRAST04	16		
Length in TC Header	NMRAST10	16		
Number of Received Bytes	NMRAST11	16		



**7.1.20.3 Expected values**

A typical output is shown below.

Time	(Pkt Typ, STyp)	Data
1139979.86552	( 1,2 )	0000 0001

**7.1.20.4 RSDB Entries**

Telemetry Packet: YMRST002 – Incomplete Packet

Telemetry Parameters: In table above.

Telemetry Parameters that have subparameters are listed below.

**NMRAH111 – PckSeqCount**

NMRDH111	Segmentation Flag
NMRDH112	MR 71/1 SourceSeqCount

**NMRAH113 – DataFieldHdr PUS**

NMRDH113	MIRO 71/1 Coarse time
NMRDH114	MIRO 71/1 Fine time

**NMRAH114 – MR71/1 DataFieldHdr PUS**

NMRDH110	Data field header pad
NMRDH115	PUS version number
NMRDH116	Checksum flag
NMRDH117	Data field header spare
NMRDH118	MIRO 71/1 Packet Type
NMRDH119	MIRO 71/1 Packet Subtype

**NMRAST01 – Global PID**

NMRDST01	PID
NMRDST02	PctCategory

**NMRAST02 – Sequence Counts**

NMRDST03	Source
NMRDST04	Counter

**NMRAST04 – Packet Sequence Info**

NMRDST05	TC Type
NMRDST06	TC Sub-type

## 7.1.21 INCORRECT CHECKSUM EVENT REPORT TELEMETRY

### 7.1.21.1 Description

This report is generated when a packet has an incorrect check sum.

### 7.1.21.2 Packet Definition

Data Element	RSDB Name	Size (bits)	Value (binary)	Comment
Version Number		3		EID-A Mandatory
Type		1		EID-A Mandatory
Data Field Header Flag		1		EID-A Mandatory
Application Process ID		7		EID-A Specified, 71
Packet Category		4		EID-A Specified, Event = 1
Segmentation Flags	NMRDH111	2		EID-A Mandatory
Source Sequence Count	NMRDH112	14		Zero initially, A separate counter is used for each APID/Packet Category combination (i.e. science, housekeeping, memory dump, etc.)
Packet Length	NMRAH112	16		
Time	NMRAH113	48		Defines the time that the acquisition of the data within the packet was initiated. 4 bytes of seconds followed by 2 bytes of fractional seconds.
PUS Version	NMRDH115	3		EID-A Specified, Non-Science data
Checksum Flag	NMRDH116	1		EID-A Mandatory
Spare	NMRDH117	4		EID-A Mandatory
Packet Type	NMRDH118	8		EID-A Specified, Telecommand Verification=1
Packet Subtype	NMRDH119	8		EID-A Specified, Acceptance Failure = 2
Pad	NMRDH110	8		EID-A Specified
Source Data		16		Detailed definition on following page

### Incorrect Checksum Event Report Source Data Definition

Data Element	RSDB Name	Size (bits)	Value (binary)	Comment
Global PID	NMAST01	16		
Sequence Control	NMAST02	16		
Failure Code	NMAST03	16	2	
Packet Service Info	NMAST04	16		
Received Checksum	NMAST12	16		
Computed Checksum	NMAST13	16		

**7.1.21.3 Expected Values**

A typical output is shown below.

Time	(Pkt Typ, STyp)	Data
1139979.86552	( 1,2 )	0000 0002

**7.1.21.4 RSDB Entries**

Telemetry Packet: YMRST003 – Incorrect Checksum

Telemetry Parameters: In table above.

Telemetry Parameters that have subparameters are listed below.

**NMRAH111 – PckSeqCount**

NMRDH111	Segmentation Flag
NMRDH112	MR 71/1 SourceSeqCount

**NMRAH113 – DataFieldHdr PUS**

NMRDH113	MIRO 71/1 Coarse time
NMRDH114	MIRO 71/1 Fine time

**NMRAH114 – MR71/1 DataFieldHdr PUS**

NMRDH110	Data field header pad
NMRDH115	PUS version number
NMRDH116	Checksum flag
NMRDH117	Data field header spare
NMRDH118	MIRO 71/1 Packet Type
NMRDH119	MIRO 71/1 Packet Subtype

**NMRAST01 – Global PID**

NMRDST01	PID
NMRDST02	PctCategory

**NMRAST02 – Sequence Counts**

NMRDST03	Source
NMRDST04	Counter

**NMRAST04 – Packet Sequence Info**

NMRDST05	TC Type
NMRDST06	TC Sub-type

## 7.1.22 INCORRECT APID EVENT REPORT TELEMETRY

### 7.1.22.1 Description

This report is generated when a packet has an incorrect application ID.

### 7.1.22.2 Packet Definition

Data Element	RSDB Name	Size (bits)	Value (binary)	Comment
Version Number		3		EID-A Mandatory
Type		1		EID-A Mandatory
Data Field Header Flag		1		EID-A Mandatory
Application Process ID		7		EID-A Specified, 71
Packet Category		4		EID-A Specified, Event = 1
Segmentation Flags	NMRDH111	2		EID-A Mandatory
Source Sequence Count	NMRDH112	14		Zero initially, A separate counter is used for each APID/Packet Category combination (i.e. science, housekeeping, memory dump, etc.)
Packet Length	NMRAH112	16		
Time	NMRAH113	48		Defines the time that the acquisition of the data within the packet was initiated. 4 bytes of seconds followed by 2 bytes of fractional seconds.
PUS Version	NMRDH115	3		EID-A Specified, Non-Science data
Checksum Flag	NMRDH116	1		EID-A Mandatory
Spare	NMRDH117	4		EID-A Mandatory
Packet Type	NMRDH118	8		EID-A Specified, Telecommand Verification = 1
Packet Subtype	NMRDH119	8		EID-A Specified, Acceptance Failure = 2
Pad	NMRDH110	8		EID-A Specified
Source Data		16		Detailed definition on following page

### Incorrect APID Event Report Source Data Definition

Data Element	RSDB Name	Size (bits)	Value (binary)	Comment
Global PID	NMAST01	16		
Sequence Control	NMAST02	16		
Failure Code	NMAST03	16	3	
Packet Service Info	NMAST04	16		

**7.1.22.3 Expected Values**

A typical output is shown below.

Time	(Pkt Typ, STyp)	Data
1139979.86552	( 1,2 )	0000 0003

**7.1.22.4 RSDB Entries**

Telemetry Packet: YMRST004 Incorrect APID

Telemetry Parameters: In table above.

Telemetry Parameters that have subparameters are listed below

**NMRAH111 – PckSeqCount**

NMRDH111	Segmentation Flag
NMRDH112	MR 71/1 SourceSeqCount

**NMRAH113 – DataFieldHdr PUS**

NMRDH113	MIRO 71/1 Coarse time
NMRDH114	MIRO 71/1 Fine time

**NMRAH114 – MR71/1 DataFieldHdr PUS**

NMRDH110	Data field header pad
NMRDH115	PUS version number
NMRDH116	Checksum flag
NMRDH117	Data field header spare
NMRDH118	MIRO 71/1 Packet Type
NMRDH119	MIRO 71/1 Packet Subtype

**NMRAST01 – Global PID**

NMRDST01	PID
NMRDST02	PctCategory

**NMRAST02 – Sequence Counts**

NMRDST03	Source
NMRDST04	Counter

**NMRAST04 – Packet Sequence Info**

NMRDST05	TC Type
NMRDST06	TC Sub-type

## 7.1.23 INVALID COMMAND CODE EVENT REPORT TELEMETRY DEFINITION

### 7.1.23.1 Description

This report is generated when a telecommand contains an invalid command code.

### 7.1.23.2 Packet Definition

Data Element	RSDB Name	Size (bits)	Value (binary)	Comment
Version Number		3		EID-A Mandatory
Type		1		EID-A Mandatory
Data Field Header Flag		1		EID-A Mandatory
Application Process ID		7		EID-A Specified, 71
Packet Category		4		EID-A Specified, Event = 1
Segmentation Flags	NMRDH111	2		EID-A Mandatory
Source Sequence Count	NMRDH112	14		Zero initially, A separate counter is used for each APID/Packet Category combination (i.e. science, housekeeping, memory dump, etc.)
Packet Length	NMRAH112	16		
Time	NMRAH113	48		Defines the time that the acquisition of the data within the packet was initiated. 4 bytes of seconds followed by 2 bytes of fractional seconds.
PUS Version	NMRDH115	3		EID-A Specified, Non-Science data
Checksum Flag	NMRDH116	1		EID-A Mandatory
Spare	NMRDH117	4		EID-A Mandatory
Packet Type	NMRDH118	8		EID-A Specified, Telemetry Verification = 1
Packet Subtype	NMRDH119	8		EID-A Specified, Acceptance Failure = 2
Pad	NMRDH110	8		EID-A Specified
Source Data		16		Detailed definition on following page

### Invalid Command Code Event Report Source Data Definition

Data Element	RSDB Name	Size (bits)	Value (binary)	Comment
Global PID	NMRAST01	16		
Sequence Control	NMRAST02	16		
Failure Code	NMRAST03	16	4	
Packet Service Info	NMRAST04	16		
FC4_Par3	NMRAST14	16		
FC4_Par4	NMRAST15	16		

### 7.1.23.3 Expected Value

A typical output is shown below.

```
Time          (Pkt Typ, STyp)  Data
1139979.86552  ( 1,2 )  0000 0004
```

**7.1.23.4 RSDB Inputs**

Telemetry Packet: YMRST005 – InvalidCmdCode

Telemetry Parameters: In tables above

Telemetry Parameters that have subparameters are listed below.

**NMRAH111 – PckSeqCount**

NMRDH111 Segmentation Flag

NMRDH112 MR 71/1 SourceSeqCount

**NMRAH113 – DataFieldHdr PUS**

NMRDH113 MIRO 71/1 Coarse time

NMRDH114 MIRO 71/1 Fine time

**NMRAH114 – MR71/1 DataFieldHdr PUS**

NMRDH110 Data field header pad

NMRDH115 PUS version number

NMRDH116 Checksum flag

NMRDH117 Data field header spare

NMRDH118 MIRO 71/1 Packet Type

NMRDH119 MIRO 71/1 Packet Subtype

**NMRAST01 – Global PID**

NMRDST01 PID

NMRDST02 PctCategory

**NMRAST02 – Sequence Counts**

NMRDST03 Source

NMRDST04 Counter

**NMRAST04 – Packet Sequence Info**

NMRDST05 TC Type

NMRDST06 TC Sub-type

**7.1.24      ADDITIONAL ROSETTA TELEMETRY RELEVANT TO MIRO**

NMRASDTA – MIRO SDT SAMP

NMRASDTB – MIRO SDT SAMP Redundant

NMRAT002 – PAY413 – MIRO Temp 2B

NMRAT101 – PAY414 – MIRO Temp 1A

NMRAT102 – PAY412 – MIRO Temp 2A