

Earth and Space Science

RESEARCH ARTICLE

10.1029/2024EA003576

Key Points:

- We detail the pre-flight and initial in-flight characterization and calibration of the NASA Lucy mission's Terminal Tracking Camera system
- Pre-flight results primarily include sensor and system characterization (gain, dark current, linearity, flat field, bad pixels, and radiometry estimates)
- We describe the calibration pipeline as well as initial in-flight optical assessment and refined radiometry results from Earth, Moon and star field imaging

Correspondence to:

Y. Zhao,
amyzhao@asu.edu

Citation:

Zhao, Y., Bell, J. F., III, Sahr, E., Lessac-Chenen, E., Adam, C., Cisneros, E., et al. (2024). Pre-flight and in-flight calibration and performance of the Terminal Tracking Cameras (TTCams) on the NASA Lucy mission. *Earth and Space Science*, 11, e2024EA003576. <https://doi.org/10.1029/2024EA003576>

Received 6 FEB 2024

Accepted 18 JUL 2024

Author Contributions:

Conceptualization: J. F. Bell III

Data curation: J. F. Bell III, E. Sahr, E. Cisneros, M. Caplinger, M. Ravine, J. Schaffner, J. Shamah

Formal analysis: Y. Zhao, E. Sahr, E. Lessac-Chenen, C. Adam, A. Winhold, M. Caplinger, M. Ravine, J. Schaffner, J. Shamah

Investigation: J. F. Bell III, A. Winhold

Methodology: Y. Zhao, J. F. Bell III

Resources: J. F. Bell III, M. Caplinger, M. Ravine

Software: Y. Zhao, E. Cisneros







Supervision: J. F. Bell III

Validation: Y. Zhao, E. Sahr, E. Lessac-Chenen, C. Adam, A. Winhold, M. Caplinger, M. Ravine, J. Schaffner, J. Shamah, S. Mottola

© 2024. The Author(s).

This is an open access article under the terms of the [Creative Commons Attribution-NonCommercial-NoDerivs License](#), which permits use and distribution in any medium, provided the original work is properly cited, the use is non-commercial and no modifications or adaptations are made.

Pre-Flight and In-Flight Calibration and Performance of the Terminal Tracking Cameras (TTCams) on the NASA Lucy Mission

Y. Zhao¹ , J. F. Bell III¹, E. Sahr², E. Lessac-Chenen² , C. Adam² , E. Cisneros¹ , A. Winhold¹, M. Caplinger³, M. Ravine³ , J. Schaffner³ , J. Shamah³, and S. Mottola⁴

¹School of Earth and Space Exploration, Arizona State University, Tempe, AZ, USA, ²KinetX Inc., Tempe, AZ, USA,

³Malin Space Science Systems, Inc., San Diego, CA, USA, ⁴Institute for Planetary Research, DLR, Berlin, Germany

Abstract The Terminal Tracking Camera (TTCam) imaging system on the NASA Lucy Discovery mission consists of a pair of cameras that are being used mainly as a navigation and target acquisition system for the mission's asteroid encounters. However, a secondary science-focused function of the TTCam system is to provide wide-angle broadband images over a large range of phase angles around close approach during each asteroid flyby. The scientific data acquired by TTCam can be used for shape modeling and topographic and geologic analyses. This paper describes the pre-flight and initial in-flight calibration and characterization of the TTCams, including the development of a radiometric calibration pipeline to convert raw TTCam images into radiance and radiance factor (I/F) images, along with their uncertainties. Details are also provided here on the specific calibration algorithms, the origin and archived location of the required ancillary calibration files, and the archived sources of the raw calibration and flight data used in this analysis.

1. Introduction

The Trojan asteroids of Jupiter are a large population of relatively small, relatively low-albedo asteroids that orbit the Sun in two distinct “clouds” of small bodies centered near the stable Jupiter-Sun L4 and L5 Lagrange points some 60° ahead of and behind Jupiter itself. Studying the Trojans provides an opportunity to learn more about the history and formation of the solar system, including the possible origins of organic materials that ultimately led to the development of life on Earth (e.g., Levison et al., 2021). The NASA Lucy Trojan asteroid Discovery mission is the first mission to explore the Trojans up close. Lucy was launched in October 2021 and between 2023 and 2033 the mission will nominally conduct flybys of two main belt asteroids and five different Trojan systems consisting of at least eight different asteroids, because some of those systems are binaries or include satellites. Details about the Lucy mission science goals, mission profile, and instrument suite can be found in Levison et al. (2021) and Olkin et al. (2021).

One of the instrument systems on Lucy is called the Terminal Tracking Camera (TTCam; Bell et al. (2023)), which consists of a pair of identical digital cameras (for block redundancy) and an associated Digital Video Recorder (DVR) electronics control/power supply electronics for each, located on the spacecraft's Instrument Pointing Platform (IPP). Only one camera is intended to be used at a time. The primary camera, intended for nominal use during the mission, is referred to as TTCam1 (connected to DVR1, serial number 194503) and the secondary or backup camera is referred to as TTCam2 (connected to DVR2, serial number 194504). Figure 1 shows both TTCam1 and TTCam2 on the Lucy spacecraft.

The TTCams are primarily designed to perform a guidance, navigation, and control engineering function for the mission by autonomously imaging each asteroid target during approach and allowing the spacecraft's onboard-determined centroid of the asteroid's location in the field of view (FOV) to update the IPP's knowledge of the position of the object (Good et al., 2022). Accurate knowledge of the position of the asteroids in the TTCam images will allow Lucy's higher spatial resolution instruments to achieve the best possible pointing.

However, the TTCams also have secondary uses as science cameras that can help to fulfill some of the goals of the Lucy mission (Bell et al., 2023; Levison et al., 2021). Specifically, after the terminal tracking activity is complete (just a few minutes before each closest approach), TTCam images will continue to document the spatially-resolved radiance of all of the sunlit parts of each asteroid over a wide range of phase angles. These images will help to significantly constrain the shape and thus the volume of the target asteroids (and thus, when combined

Writing – original draft: Y. Zhao,
E. Sahr, A. Winhold
Writing – review & editing: Y. Zhao,
J. F. Bell III, E. Lessac-Chenen, S. Mottola



Figure 1. The two TTCam camera heads on the Lockheed Martin-built Lucy spacecraft at the Astrotech testing facility in Florida, being inspected by Ryan Bronson of Collins Aerospace, the manufacturer of the TTCam optics. For scale, each camera's semi-conical sunshade is ≈ 15 cm long. Lockheed Martin photo PIRA #SSS2023010009, used with permission. Photo credit: Michael Ravine/Malin Space Science Systems.

with mass estimates from the mission's gravity experiment, their densities), as well as characterize their surface geology. Additional details on the science goals and measurement requirements for the TTCams is provided by Bell et al. (2023).

The TTCams have a focal length of 29.7 mm and a focal ratio of $f/2.95$, and a spectral range of 425–675 nm. Details on the camera design are provided in Appendix A, and in Bell et al. (2023). This paper describes the pre-flight and initial in-flight calibration of the TTCam flight instruments. Section 2 describes the pre-flight instrument characterization measurements, including linearity, scale factor, dark current, responsivity, and more. Section 3 describes the data calibration pipeline for TTCam science data. Section 4 describes the in-flight validation of our calibration measurements.

2. Pre-Flight Characterization Measurements and Results

Pre-flight characterization measurements, taken both at room temperature and in a thermal-vacuum (TVAC) chamber, were analyzed for assessing the performance of the optical chain and of the 12-bit CMOS detector and electronics signal chain. Pre-flight calibration data were taken at the Malin Space Science Systems (MSSS) facility where the cameras were assembled, in San Diego, California. Calibration images were acquired with both flight cameras as well as a flight spare, and at four different sensor analog gain settings (1.0, 1.5, 2.0, and 3.5, with 1.0 being the default used for flight observations). Analysis of much of the calibration data set was carried out independently by researchers at both MSSS and ASU, with results in good agreement. Here, we present the consensus results of the analyses of the pre-flight calibration data, focusing primarily on sensor and optics performance.

2.1. Linearity

To verify the linearity of the detector, we took images of an integrating sphere fitted with a quartz-tungsten halogen (QTH) light source at different effective exposure times, from zero and up to (and beyond) exposures resulting in detector saturation. The QTH light source is powered by a Newport/Oriel OPS-Q250 power supply which keeps the lamp's ripple to less than 0.05% rms. Figure 2 shows representative responses of the detectors as a function of exposure time, which we calculated with the average value of a centered 500×500 active pixel region at an analog gain setting of 1.0. Analysis of the TTCam1 detector data from between 178 12-bit Data Numbers (DN; 10 DN above the bias level) to around 4050 DN shows a maximum deviation of 1.9% from a linear fit.

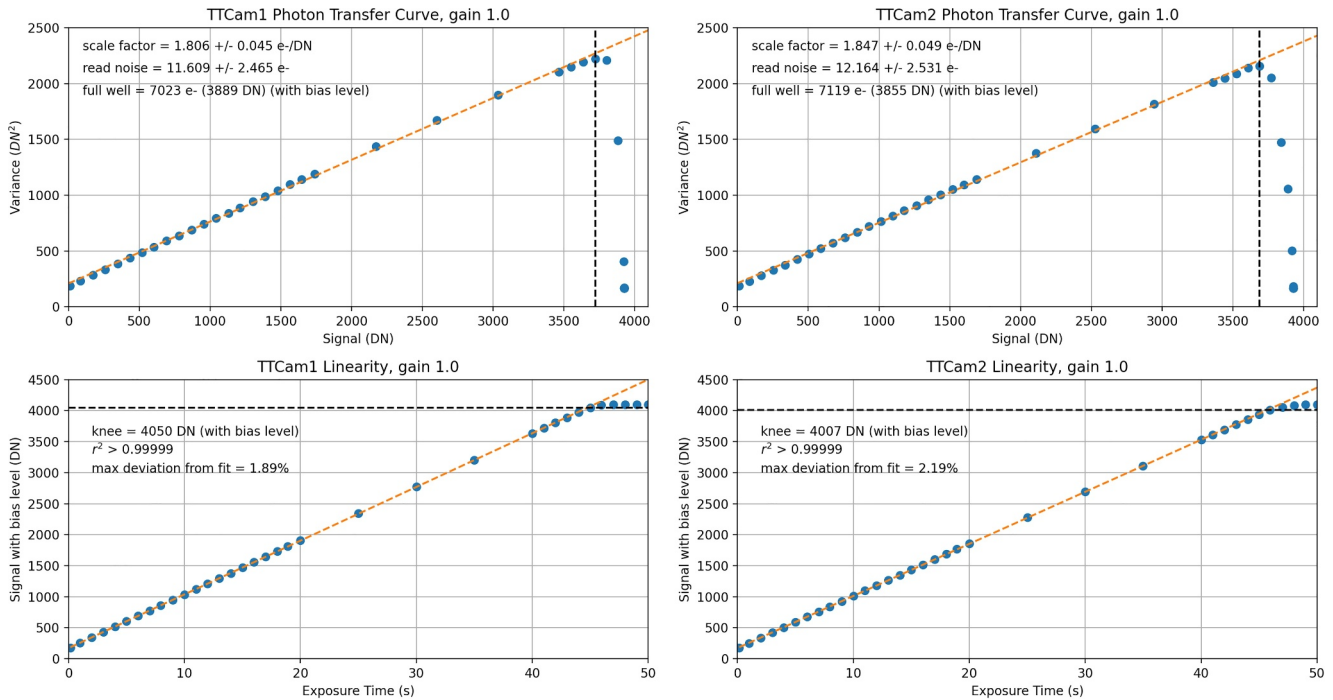

Figure 2. Photon transfer analysis and linearity of the TTCam1 and TTCam2 sensors.

Analysis of the TTCam2 detector showed a similar linearity fit between 179 DN and 4007 DN, with a maximum deviation of 2.2%. More discussion on linearity, centered on calculations of the detector full well, are provided in the next section.

2.2. System Scale Factor, Read Noise, and Full Well

The same QTH light source and integrating sphere were used to collect a series of images designed so that the photon transfer method of Janesick et al. (1987) could be used to derive the sensor and electronics system scale factor g (e^-/DN) (sometimes referred to more generically as the “gain”), as a function of the sensor’s analog gain state as set in the camera head electronics. Starting with an equation describing the raw signal seen on a pixel in DN, decomposed into its components:

$$S_{DN} = N_{e^-}/g + b_{DN} \quad (1)$$

where N_{e^-} is the number of electrons detected in each pixel and b_{DN} is the constant bias offset level in DN. Propagation of errors gives us an equation for the variance of the raw signal in DN^2 :

$$\sigma_{S, DN}^2 = \frac{\sigma_{N, e^-}^2}{g^2} + \sigma_{R, DN}^2 \quad (2)$$

where $\sigma_{R, DN}$, the read noise of the sensor in DN (not a function of bias level), has been added. We can rewrite as

$$\sigma_{S, DN}^2 = \frac{N_{DN}}{g} + \sigma_{R, DN}^2 \quad (3)$$

since $\sigma_{N, e^-}^2 = N_{e^-}$ due to photon counting (Poisson) statistics and $N_{DN} = N_{e^-}/g$. The point of photon transfer analysis is to (a) determine the read noise, and (b) determine the system scale factor (also known as gain), so we rewrite the above equation as:

Table 1
Photon Transfer Analysis Results

Camera	Scale factor (e^-/DN)	Read noise (e^-)	Full well (e^-)	Maximum deviation from linearity (%)
TTCam1	1.806 ± 0.045	11.609 ± 2.465	7,023	1.89
TTCam2	1.847 ± 0.049	12.164 ± 2.531	7,119	2.19

$$g = \frac{N_{DN}}{\sigma_{S,DN}^2 - \sigma_{R,DN}^2} \quad (4)$$

Now we can consider two images of identical uniform “flat fields.” The difference between these identical flat field images, *FLATDIFF*, can be defined as:

$$\langle FLATDIFF \rangle = \langle S_{DN,1} - S_{DN,2} \rangle \quad (5)$$

Error propagation gives us:

$$\sigma_{FLATDIFF}^2 = \sigma_{S,DN,1}^2 + \sigma_{S,DN,2}^2 = 2\sigma_{S,DN}^2 \quad (6)$$

Now consider two bias, or 0 ms exposure images. For each image, the signal in each pixel can be described as:

$$B_{DN} = b_{DN} \pm \sigma_{R,DN} \quad (7)$$

we can then define the *BIASDIFF* as:

$$\langle BIASDIFF \rangle = \langle B_{DN,1} - B_{DN,2} \rangle = \langle \sigma_{R,DN,1} - \sigma_{R,DN,2} \rangle \quad (8)$$

and in terms of σ ,

$$\sigma_{BIASDIFF}^2 = \sigma_{B,DN,1}^2 + \sigma_{B,DN,2}^2 = 2\sigma_{R,DN}^2 \quad (9)$$

Going back to Equation 3, we can now plug in our equations for $\sigma_{S,DN}^2$ and $\sigma_{R,DN}^2$ to get:

$$g = \frac{N_{DN}}{\sigma_{S,DN}^2 - \sigma_{R,DN}^2} \quad (10)$$

$$= \frac{2N_{DN}}{\sigma_{FLATDIFF}^2 - \sigma_{BIASDIFF}^2} \quad (11)$$

$$= \frac{2(S_{DN} - B_{DN})}{\sigma_{FLATDIFF}^2 - \sigma_{BIASDIFF}^2} \quad (12)$$

$$= \frac{[(\langle S_{DN,1} \rangle + \langle S_{DN,2} \rangle) - (\langle B_{DN,1} \rangle + \langle B_{DN,2} \rangle)]}{\sigma_{FLATDIFF}^2 - \sigma_{BIASDIFF}^2} \quad (13)$$

To use the photon transfer method, pairs of images were taken of the integrating sphere at increasing exposure times, and then the average signal level of a centered 500 by 500 pixel box was plotted against the variance of the values in that box, after subtracting the bias. Following Janesick et al. (1987), the scale factor was calculated as the inverse of the slope of the linear portion of the photon transfer curve, the read noise was calculated as the intercept of the linear fit, and the full well was determined at the “knee” point where the photon transfer curve deviates from linearity. Figure 2 shows the resulting photon transfer curves at an analog gain setting of 1.0 for each camera. Table 1 summarizes the results of the photon transfer and linearity analysis. With this gain and readout noise, the system is photon-noise-limited for signals larger than about 300 DN.

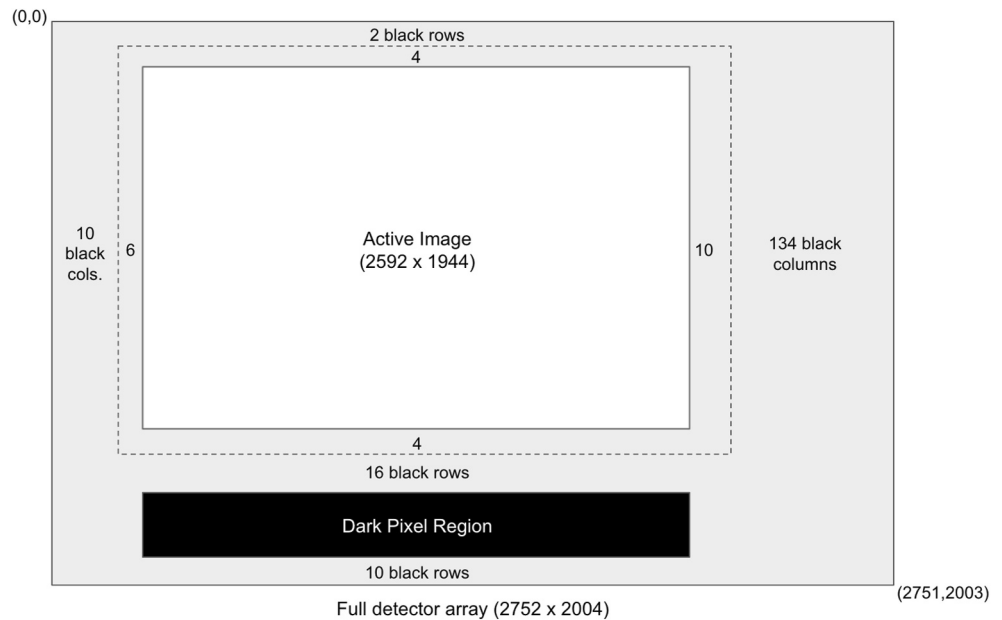

Figure 3. Schematic diagram of the full TTCam CMOS detector array, showing the active image area and the masked pixel region (area sizes are not shown to scale). Pixels in the black region (zero-based rows 1970:1993 and columns 16:2607) are used for the assessment of bias and dark current signals for calibration images where these sensor pixels are downlinked. There is no statistical difference between the dark region and the active image area in pre-flight darks. Because of a limit on the image size that can be transferred into the spacecraft's terminal tracking algorithm, however, only the pixels in the 2592×1944 active area are read out during each asteroid encounter. When typical 2592×2000 pixel calibration images are read out, the gray areas are ignored in processing.

2.3. Dark Current and Bias Offset Level

The TTCam sensor electronics adds a constant offset bias voltage to every raw image that equals a 12-bit DN value of 168. The 168-DN black level “DC offset” was recommended by the sensor vendor and is the default setting of the on-die black level control logic. In addition, CMOS sensors are known to produce a small amount of dark current (signal produced by thermal electrons), especially at elevated temperatures. In order to characterize the temperature dependence of the dark current as well as to search for any potential temperature dependence of the bias signal, a series of non-illuminated 12-bit uncompanded (see Section 3.1.1) images at a constant exposure time (2 s) were taken with the cameras in a thermal vacuum chamber over a wide range of temperatures from -50 to 50°C . The average and standard deviation were calculated from the center half portion of the active sensor array (see Figure 3) for each camera, a rectangular portion of 1002 by 1372 pixels, with no known bad pixels. No temperature-dependent bias variations were observed over the expected temperature range of flight observations below -10°C . Any anomalous deviations in pixel by pixel dark current behavior is noted through bad pixel flagging in the calibration pipeline, as described in Section 3.2.1.

We can model the dark current rate, D , in e^-/ms as a response to temperature with an exponential function of the following form:

$$D = C_1 + C_2 \exp C_3 T \quad (14)$$

where C_1 is the background level, C_2 and C_3 are constants, and T is the camera head temperature in $^\circ\text{C}$. The temperature sensor in the camera head is on the digital board next to the connector, about 3 cm from the image sensor, which is on another board. The camera is small and the boards are reasonably well-coupled conductively, so the temperature offset is no more than 5°C and likely less. Figure 4 shows the resulting data and model fits for the bias and dark current model for an analog gain setting of 1.0, the setting used in flight, for each flight camera. Table 2 summarizes the parameters of the TTCam dark current model for an analog gain setting of 1.0, including an assessment of the uncertainties on the derived model coefficients. While the same pre-flight, uncompanded data set was used to determine the dark current model of the different flight companding modes, the difference in

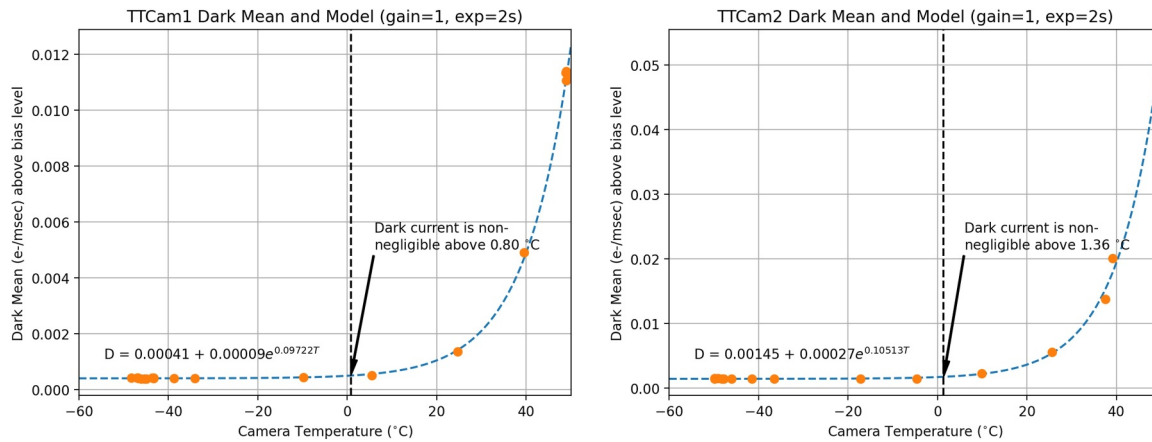

Figure 4. Dark current analysis of the TTCam1 (left) and TTCam2 (right) sensors. Each curve was fitted to an exponential model, and the point where dark current was determined to be nonnegligible was determined by finding the point on the model where the dark current rises >1% above the background level.

the C_1 term of the dark model is due to the difference in treatment of the bias offset level for each companding mode, as described in Section 3.1.1. There is a small decrease in the accuracy of the model at higher temperatures, which could decrease the overall radiometric accuracy of the calibration at high temperatures (above +10°C). However, nominally, the cameras will operate below around -10°C even while in the inner solar system (during the Earth Gravity Assist flybys), and will be significantly colder during the Trojan flybys at 5 AU. Therefore, we do not anticipate that dark current will add any significant uncertainty to the calibration accuracy for the short exposure times (a few to a few tens of ms) used for TTCam imaging of the primary Trojan asteroid targets. Indeed, dark current correction will only be applied in the calibration pipeline to images taken at an operating temperature and exposure time for which the dark current exceeds the nonnegligible threshold point of >1% above background, as shown in Figure 4.

2.4. Pixel Responsivity Variations (“Flat Field”) Characterization

Several hundred flat field images were taken with each camera by imaging into a uniform integrating sphere at a variety of camera orientations to verify source uniformity. A master flat field was created for each flight model by averaging six of the flat field images acquired at an analog gain setting of 1.0, each normalized by exposure time, and then normalizing the overall average so that its mean is 1.0. Average pixel-to-pixel variations in the normalized responsivity of the entire sensor are approximately 1.7% and 2.5% for TTCam1 and TTCam2, respectively. However, the variations are lower—1.1% and 2.3%—for the central 500 × 500 pixel regions of each sensor. Figure 5 shows the master flat field images created for each flight model. The average standard deviations of the normalized master flat fields are ±0.0058 and ±0.0059 for TTCam1 and TTCam2, respectively, showing that these science-focused flat field images meet the SNR ≥ 100 requirement (Bell et al., 2023). We examined and processed additional flat field images acquired in other orientations and at other exposure times, but did not see any statistically-significant variations compared to the master flat fields described above.

Table 2
Dark Model Parameters

Camera	Flight companding mode	C_1	C_2	C_3
TTCam1	Square root	0.000407 ± 0.000008	0.000092 ± 0.000008	0.097216 ± 0.001770
	Linear	0.015161 ± 0.000008	0.000092 ± 0.000008	0.097216 ± 0.001770
TTCam2	Square root	0.001446 ± 0.000039	0.000268 ± 0.000055	0.105134 ± 0.005696
	Linear	0.156846 ± 0.000268	0.000268 ± 0.000055	0.105134 ± 0.005696

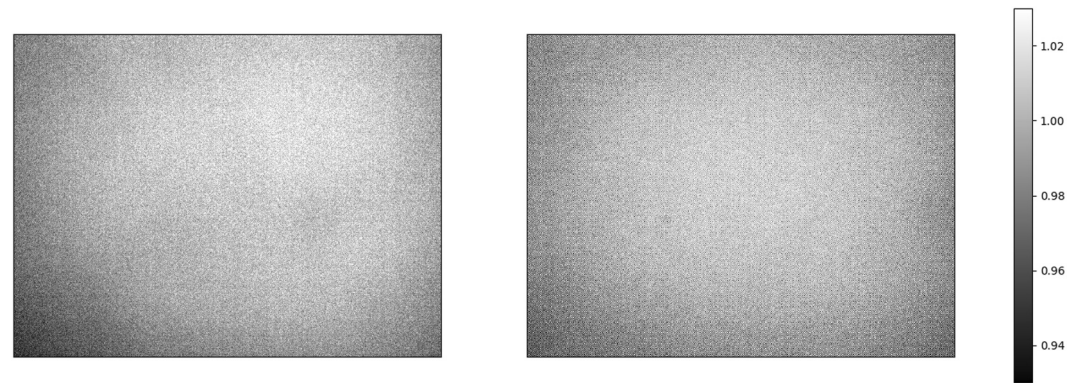

Figure 5. (left) Flat field for TTCam1. (right) Flat field for TTCam2.

2.5. Bad Pixel Maps

No “always fully unresponsive” or “always fully saturated” pixels were identified in images from either flight TTCam. To search for evidence of whether some pixels have anomalously high or anomalously low responsivity compared to the average, we looked at the ratio of two averaged flat field images at different exposure times, and compared those values to the ratio of their exposure times. We were not able to identify any such anomalously-responsive pixels that deviated more than 1% above or below the ratio of the exposure times, in either flight camera. We created what we call master bad pixel maps for each camera that flag any identified “bad” pixels by assigning a value of 0 to good pixels, and 1 to bad pixels. Since we found that there were no intrinsically dead, always saturated, or anomalously-responsive pixels in either flight sensor prior to launch, the initial pre-launch master bad pixel maps are simply full active-area (see Figure 3) 2592×1944 pixel images of all 0's for both flight cameras. During the calibration of in-flight data products, however, any saturated or nonlinear pixels are also flagged in a separate unique bad pixel map that accompanies each calibrated image (see Section 3.2.1 below).

2.6. Instantaneous Field of View (IFOV), Field of View (FOV), and Geometric Distortion

The FOV of the flight TTCams was measured by mounting the instruments on a precision rotation stage and imaging a circular target at varying angular positions, at room temperature and pressure. The center of the target was calculated for each image, and the center location versus angle was used to compute the IFOV. The FOV was then calculated by multiplying the derived IFOV by the 2592 by 1944 pixel size of the active area of the sensor (Figure 3). The results for the two flight units are presented in Table 3.

Robust distortion measurements of the TTCam optics could not be made during pre-flight calibration, partially because of the long focal length of the cameras. However, the lens manufacturer (Collins Aerospace) measured the distortion of the lens assemblies at the component level before delivery to MSSS, and the worst-case distortions at the extremes of the diagonals were reported to be 0.11% for TTCam1 and 0.10% for TTCam2. These very low initial distortion estimates were qualitatively confirmed by inspection of the images used to calculate the IFOV and FOV above, and the similarly low level of distortion in flight was characterized by observations of well-known star clusters (see Section 4.5).

2.7. Modulation Transfer Function (MTF)

The system MTF of the TTCam flight cameras was estimated from images of buildings and other features observed in focus at a distance (\sim hundreds of m to ~ 1 km) and photographed under ambient pressure and

Table 3
Calculated IFOV and FOV for the TTCam Flight Instruments

Camera	IFOV ($\mu\text{rad}/\text{pix}$)	Horizontal FOV	Vertical FOV	Diagonal FOV
TTCam1	73.9	10.97°	8.23°	13.71°
TTCam2	73.6	10.94°	8.20°	13.67°

temperature conditions out of an open window in one of the cleanrooms at MSSS. Sharp linear bright/dark edges of features (like bright walls and dark windows, or edges of buildings against the sky) were used to estimate the contrast at the Nyquist frequency of the detector (227 line pairs/mm). The results indicated estimated system MTF values of 0.16 and 0.14 at Nyquist for TTCam1 and TTCam2, respectively. These MTF results exceed the system level requirement (0.1) and are considered to be only minimum estimates because the images were taken in uncharacterized conditions of atmospheric humidity or haziness and the optical system's performance was tuned for vacuum conditions. Thus, MTF is expected to be greater in flight and excellent image quality has indeed been confirmed from cruise images of stars, the Earth, and the Moon (see Section 4).

2.8. Pre-Flight Radiometric Coefficients

Pre-flight analysis of the wavelength-dependent properties of the TTCam sensors and optics (Appendix A) were used to derive estimated initial radiometric coefficients that can be used to convert values of calibrated DN/S to physical units of radiance. Consistent with the definition of the coefficient as shown in Equation 18 below, initial values were estimated from advance component-level knowledge of the system scale factor, the transmission and throughput of the optics, and the quantum efficiency of the sensor. We analyzed the vendor-supplied system-level throughput data, validated with frames taken of the integrating sphere, to derive a radiometric coefficient value of $(1.26 \pm 0.10) \times 10^{-6} \left(\frac{s}{DN}\right) (\mu W/cm^2/nm/sr)$ for TTCam1 and TTCam2 over a wavelength range of 420–680 nm. Refinement and correction of these initial radiometric coefficients in flight for each camera is discussed in Section 4.2.

3. Data Reduction and Validation

3.1. Onboard Image Processing

3.1.1. 12-bit to 8-bit Companding (and Decomparing)

“Companding” is a portmanteau blend of the words “compressing” and “expanding,” and refers to the process of compressing the original 12-bit (0–4,095) DN values of each raw TTCam pixel onboard down to 8 bits (0–255) of dynamic range, and then expanding the data back to 12-bit in ground data processing after downlink. Companding is nominally performed in what is called “mode 17” (0 × 11 in hex) using an onboard square-root-based lookup table (Appendix B) to scale the data down to a smaller number of bits per pixel so that Poisson (shot) noise is not encoded or downlinked in the telemetry (e.g., Bell et al., 2017; Malin et al., 2013). The opposite process, expanding the downlinked 8-bit pixel values back to an estimate of their original linear 12-bit values, is referred to as “decompanding,” and is part of the initial process that the Lucy Science Operations Center (SOC) uses to create the raw TTCam Uncalibrated Data Products (UDPs) for use by the science team. The default lookup table to convert 8-bit square-root companded mode 17 downlinked images back to 12-bit values is presented in Appendix C. While the onboard 12-bit to 8-bit square-root companding lookup table can be modified in flight if needed, the expectation is that the mode 17 TTCam lookup table in Appendix B will nominally be the default for tracking and encounter mode images acquired during the entire mission. During cruise, other linear companding modes such as divide-by-16 (mode 27; 0 × 1b), or least-significant-bits only (mode 19; 0 × 13) are also being tested, as ways to validate the radiometric calibration of the images. The subtraction of the bias level of 168 DN is dependent on the companding mode. Square root companding will return pixel values with the bias level pre-subtracted. Otherwise, the bias subtraction will still be performed in the calibration pipeline (see Section 3.2.2). Regardless of the companding mode used, all TTCam flight images will nominally be downlinked to Earth as 8-bit companded images.

3.1.2. Lossless (PPMd) Compression

TTCam images are transferred from the camera head to the DVR and stored in flash memory as uncompressed raw images. Compression of the raw images is achieved in two steps: first, the images are compressed from 12-bit to 8-bit using a square-root-like lookup table as described above (the default for tracking and encounter imaging) that avoids encoding of shot noise in the output 8-bit data. Then the 8-bit images are transferred to the spacecraft computer where they are subsequently compressed further using the PPMd compression algorithm (Shkarin, 2001). Additional details on TTCam onboard image compression are provided by Bell et al. (2023). As a benchmark, using this combination of companding and lossless compression, compression ratios of 3:1 to 4.5:1 have been achieved in the downlinked data volume for early cruise star field images. Compression ratios expected

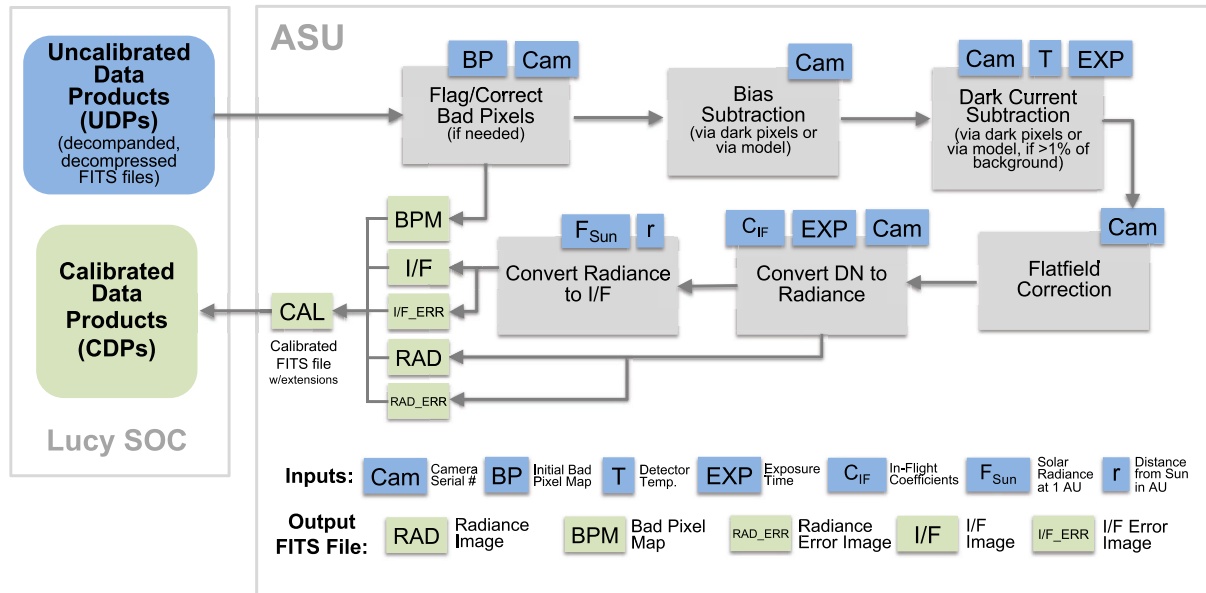

Figure 6. Flowchart of the TTCam calibration pipeline.

for the Trojan targets are approximately 2:1, based on extended object imaging with previous heritage image systems like those flown on OSIRIS-REx (Bos et al., 2020).

3.2. Radiometric Calibration Pipeline

To help create the highest possible quality TTCam data set for science and archival purposes, we developed a radiometric calibration pipeline which takes as input the decompanded 12-bit raw images, camera ID, temperature, exposure time, the radiance of the Sun in the TTCam bandpass at the heliocentric distance of the observation, and a set of pre-flight and in-flight derived ancillary calibration files to convert raw data to units of radiance and radiance factor (or I/F, defined below). The pipeline corrects for bad pixels, dark current, bias offset, and pixel-to-pixel responsivity (flat field) variations, and scales the pixel data values by the derived radiometric calibration coefficient. Figure 6 provides a flow chart of the calibration pipeline.

We can also summarize the calibration pipeline mathematically, starting with an equation describing the components of the raw signal $DN_{i,j}$ that are measured by a single pixel (i, j):

$$DN_{i,j} = \frac{A_o \Omega t_{exp}}{g F_{i,j}} \int_{\lambda} QE_{\lambda} T_{\lambda} R_{\lambda} L_{\lambda} \frac{\lambda}{hc} d\lambda + B_{i,j} + D_{i,j} \quad (15)$$

where $A_o \Omega$ in [m²sr] is the entendue, or optical throughput, a product of the aperture area A_o and the pixel FOV solid angle Ω ; t_{exp} in [sec] is the exposure time; g in [e⁻/DN] is the system scale factor, $F_{i,j}$ [unitless] is the normalized relative responsivity of that pixel (flat field); $B_{i,j}$ in [DN] is the bias offset; $D_{i,j}$ in [DN] is the dark current; QE_{λ} in [e⁻/ph] is the quantum efficiency; T_{λ} [unitless] is the optical transmission; R_{λ} [unitless] is the filter transmission; L_{λ} in [$\frac{W}{m^2 \text{srnm}}$] is the spectral radiance incident on the aperture; and $\frac{\lambda}{hc}$ in [ph/J] is the conversion factor between energy and photon flux.

Via calibration, we want to ultimately derive the mean, bandpass-integrated spectral radiance incident on the camera's front aperture. We can define this value as:

$$\langle L_{\lambda} \rangle = \frac{\int_{\lambda} r_{\lambda} L_{\lambda} \frac{\lambda}{hc} d\lambda}{\int_{\lambda} r_{\lambda} \frac{\lambda}{hc} d\lambda} \quad (16)$$

Table 4
Flagged Nonlinearity and Saturated Pixel Values

Camera	Companding mode ^a	Non-linearity flag	Saturated flag
TTCam1	Square root	3,721	3,923
TTCam1	Linear	3,889	4,080
TTCam2	Square root	3,687	3,923
TTCam2	Linear	3,855	4,080

^aSee Section 3.1.1.

where we define r_λ as the product of the quantum efficiency QE_λ , the optical transmission T_λ , and the filter transmission R_λ . Plugging in Equation 15 for the numerator in Equation 16 gives us:

$$\langle L_\lambda \rangle = \frac{gF_{ij}}{A_o\Omega t_{\text{exp}}} \frac{DN_{ij} - B_{ij} - D_{ij}}{\int_\lambda r_\lambda \frac{\lambda}{hc} d\lambda} \quad (17)$$

we can then define a radiometric calibration coefficient r such that:

$$r = \frac{g}{A_o\Omega \int_\lambda r_\lambda \frac{\lambda}{hc} d\lambda} \quad (18)$$

This allows us to simplify Equation 17 to:

$$\langle L_\lambda \rangle = \frac{rF_{ij}}{t_{\text{exp}}} (DN_{ij} - B_{ij} - D_{ij}) \quad (19)$$

Equation 19 forms the basis of the TTCam calibration pipeline.

3.2.1. Bad Pixel Flagging

Before any calibration and conversion of the data, we first flag any bad pixels. The pipeline defines four different categories of bad pixels: (a) Saturated pixels, (b) Nonlinear pixels, (c) Bad pixels (dead or hot pixels) as flagged in the master bad pixel map (Section 2.5), and (d) pixels with original 12-bit values below the constant 12-bit bias offset level of 168 DN.

For the bad pixel map (BPM in Figure 6), the calibration pipeline outputs a FITS extension of the same size as the uncalibrated image, with a value of 0 for each pixel, and checks each raw image for any always-saturated or always-zero pixels (flagging them with a value of 1; see Section 2.5), or saturated or nonlinear pixels based on scene brightness and companding mode (see Table 4), flagging them with a value of 2 for any saturated pixels, and a value of 3 for any nonlinear pixels (not inclusive of saturated pixels). Then the pipeline corrects for bad pixels in the bad pixel map input by replacing each bad pixel with the median of its eight immediately-surrounding pixels.

3.2.2. Bias Subtraction

For images acquired using linear 12-bit to 8-bit companding methods (modes 19 or 27; see Section 3.1.1), bias removal is included as part of the dark current subtraction process (next section), because it involves a simple subtraction of the constant bias level of 168 in 12-bit DN space. However, for images acquired using square-root companding (mode 17), the 168 DN bias is automatically subtracted prior to downlink within the camera electronics, in 12-bit DN space and prior to companding the images to 8-bit space. In the latter case, expected to be the vast majority of downlinked TTCam images, bias subtraction is not performed by the calibration pipeline.

3.2.3. Dark Current Subtraction

The bias and dark current corrections are dependent on a number of factors. First, the pipeline checks if the camera head temperature at the time of the observation from the raw data file's "T2CCHTMP" FITS header value exceeds a certain value, which our dark current analysis has determined to be the threshold value over which dark current is nonnegligible (see Section 2.3). If image temperature is under that threshold value, which will most likely always be the case during flight, then only bias subtraction needs to be performed. Bias subtraction is dependent on the companding mode of the image (see Section 3.2.2).

If the camera head temperature is higher than the threshold value, then the dark current contribution to the image is nonnegligible, and dark current correction is needed. This dark current subtraction can happen in one of two ways. First, the pipeline checks if the raw data file contains the standard masked dark pixel region (as defined in Figure 3), and if it does, it will use the average and standard deviation of the pixels in that region

(specifically, the average and standard deviation of the zero-based pixels in rows 1970 to 1993 and columns 16 to 2607; see also Bell et al., 2023) to perform the correction. This is the standard and most robust method of subtracting the bias and dark current background signal from the raw data acquired for TTCam calibration. However, if the standard masked dark pixels have not been downlinked (as will be the case for the smaller 2592×1944 pixel active-area-only terminal tracking and science images acquired during each asteroid encounter), the pipeline instead uses the dark current model and parameters described in Section 2.3 and in Table 2 and the camera head temperature at the time of the observation to calculate the dark current value to subtract from each pixel value.

3.2.4. Pixel-To-Pixel Responsivity Variations (“Flat Field”) Correction

The normalized flat field array for each camera from Section 2.4 above is divided out of the bias- and dark current-subtracted image at this step.

3.2.5. Radiometric Conversion

Referring back to Equation 19, the radiometric coefficient r converts our reduced data to calibrated physical units. Error propagation on Equation 19 gives us the following error calculation:

$$\sigma_{\langle L_\lambda \rangle}^2 = \left(\frac{\langle L_\lambda \rangle \sigma_r}{r} \right)^2 + \left(\frac{\langle L_\lambda \rangle \sigma_{F_{ij}}}{F_{ij}} \right)^2 + \left(\frac{r F_{ij} \sigma_{DN_{ij}}}{t_{\text{exp}}} \right)^2 + \left(\frac{r F_{ij} \sigma_D}{t_{\text{exp}}} \right)^2 \quad (20)$$

where $\sigma_{DN_{ij}}$ is calculated from Poisson distribution statistics on the number of electrons generated by each pixel detector, and $\sigma_{F_{ij}}$ and σ_D are the standard deviations of the averaged flat fields and dark current values, respectively.

The output of the radiometric conversion is a calibrated image the same size as the uncalibrated image, represented in physical radiance units ($\frac{\mu\text{W}}{\text{cm}^2 \text{nm sr}}$) instead of DN, and an associated extension image of the same size with the radiance error on each pixel in the same radiometric units as the calibrated image. More discussion on the error on the absolute radiometry can be found in Section 4.2.

3.2.6. I/F Conversion

It is often convenient to convert calibrated images of spatially resolved solar system objects that reflect sunlight from radiance to radiance factor, also known as “I/F”, where I is the incident radiance measured from the object of interest (calculated in Section 3.2.5 above), and πF is the irradiance of sunlight incident on the object at the time of the observation (e.g., Hapke, 2012). I/F is sometimes referred to as “approximate reflectance” because such values can be directly compared to a variety of laboratory absolute reflectance measurements of analog rock, mineral, and/or ice samples. In addition, I/F divided by the cosine of the solar incidence angle of the surface being imaged is an excellent approximation for the Lambertian albedo of a surface, if indeed that surface acts like an isotropic scatterer.

Starting with radiance calibrated data as described above, I/F for calibrated TTCam images is calculated using the following formula:

$$I/F = \frac{\langle L_\lambda \rangle}{f_{\text{sun}}/H_d^2/\pi} \quad (21)$$

where $\langle L_\lambda \rangle$ is the mean, bandpass-integrated radiance, f_{sun} is the solar radiance convolved over the TTCam bandpass at 1 AU (assumed to be $57.525 \pm 1.726 \frac{\mu\text{W}}{\text{cm}^2 \text{nm sr}}$ for both flight cameras), and H_d is the heliocentric distance of the target body at the time of the observation, in AU. The solar radiance was derived by integrating the solar spectrum over TTCam's spectral response, and then dividing out the spectral response to get the appropriate radiance units. The solar reference spectrum used was from (Colina et al., 1996), who estimated uncertainties of 0.01–0.03 mag across our spectral range of interest, which corresponds to a maximum flux uncertainty of approximately 3%. I/F is dimensionless, and I/F images of objects that are not reflecting sunlight (e.g., stars) will



Figure 7. The Rosette Nebula (just to the right and below center) and associated star field in the constellation Monoceros centered near 06 hr 29 m 38.568 s RA, +07°03'00.642" Dec. Image acquired by TTCam1 on 14 Feb. 2022 during the Launch+120 days TTCam cruise imaging campaign.

not have any particular physical meaning. Derived unitless I/F values for each pixel are stored in an additional associated extension image of the same size as the calibrated image.

The I/F error is calculated by propagating the radiance error through the I/F calculation. The following formula gives I/F error:

$$\sigma_{I/F}^2 = \left(\frac{\sigma_{<L_\lambda>}}{f_{sun}/H_d^2} \right)^2 + \left(\frac{2H_d <L_\lambda> \sigma_{H_d}}{f_{sun}} \right)^2 \quad (22)$$

Derived unitless I/F error values for each pixel are stored in an additional associated extension image of the same size as the calibrated image. The I/F error is dominated by the error on the absolute radiometric calibration, which is discussed further in Section 4.2.

4. In-Flight Calibration and Validation

During the cruise portion of the Lucy mission, a series of instrument checkouts and flight tests are being performed to validate the performance of the instruments. Figures 7 and 9 below show sample cruise images from some of these instrument checkout activities. Below, we discuss how these activities to date are pertinent for the calibration and validation of the TTCam instrument.

4.1. Dark Current Model Validation

The first few in-flight calibration activities revealed the extent of how alternate companding modes affected the bias level and consequently our calculations of the dark current contribution.

The first instrument checkout revealed a higher than expected average from the dark pixel region due to the clipping of negative-value pixels after automatic subtraction of the 168 DN bias level during square root companding. Apparently, many of these sky pixels must have had original 12-bit DN values less than the 168 DN bias level. Figure 8 shows this effect graphically, and also reveals how the presence of the bias level, which is dependent on the companding mode, affects the average of the dark pixel region, and consequently affects our method of calculating the expected dark current level, as explained in Section 3.2.3. Regardless, in TTCam images acquired during the first few years of cruise at temperatures between -10°C and -30°C , we have seen no

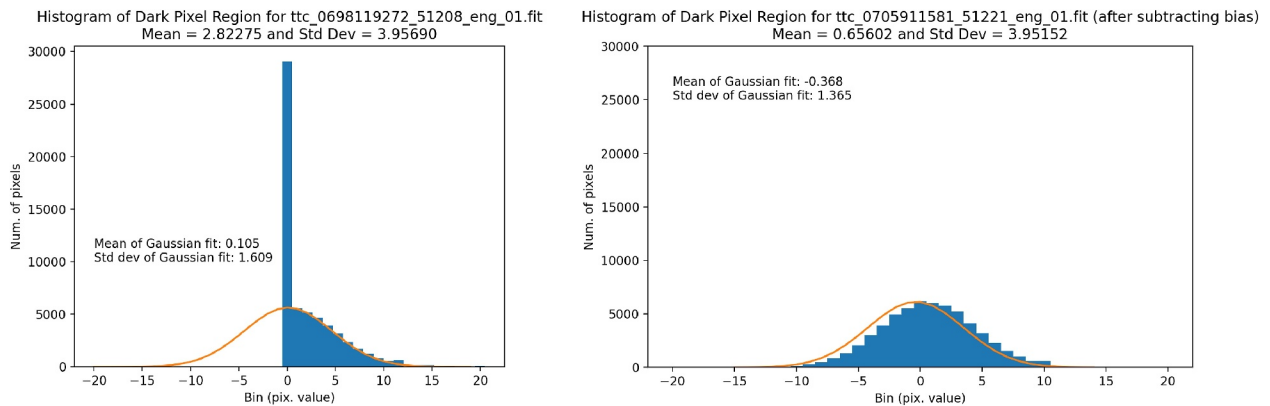

Figure 8. (left) Histogram of the dark pixel region from the Launch+20 days flight images, which were taken using square root companding mode. The automatic subtraction of the default 168 DN offset level resulted in clipping of many of the sky background pixels (large spike at DN = 0). The absence of the bias offset created a higher averaged dark pixel region, which meant an inaccurate estimate of dark current from the dark pixel region. (right) Histogram of the dark pixel region from the Launch+7 month flight images, downlinked using linear companding. What would have been “negative DN” values in the left plot were retrieved because the bias offset level is not automatically subtracted on board when using the linear companding modes. The average of this dark pixel region shows minimal dark current contribution, as expected.



Figure 9. Example TTCam1 images from the first Lucy mission Earth-gravity assist. (left) The Earth and (much dimmer) Moon in the same field of view; 13 Oct. 2022, 11:08 UTC. Range to Earth: $\sim 1,440,000$ km; range to Moon: $\sim 1,750,000$ km. (middle) Best resolution TTCam1 image of the Earth; 15 Oct. 2022, 04:52 UTC. Range to Earth: $\sim 622,000$ km. (right) Best resolution TTCam1 image of the Moon; 16 Oct. 2022, 18:14 UTC. Range to Moon: $\sim 246,000$ km.

detectable evidence of dark current signal in the raw data with exposure times up to 30s. This is consistent with the dark current model from pre-flight analysis, which predicts no statistically significant dark current below $\approx 0^\circ\text{C}$.

4.2. Extended Object Radiometry

One of the primary objectives of the TTCam calibration is to calibrate images for science objectives, which requires an accurate understanding of the radiometric conversion from instrument-specific units to universal physical radiance units. Pre-flight analysis of the instrument's optical throughput, scale factor, quantum efficiency, etc. gave us an analytical estimate of the radiometric conversion factor, which we called the radiometric coefficient. However, observations of the Earth and Moon during the gravity assists that are a part of Lucy's orbital tour give us the opportunity to validate our radiometric calibration using the Moon (and, to a lesser extent, the Earth), as a “known” radiometric source. The following sections describe the in-flight validation of our radiometric calibration pipeline.

4.2.1. Radiometric Coefficient Refinement

During Lucy's first Earth Gravity Assist (EGA1) (Spencer et al., 2024) on October 13-16, 2022, TTCam1 and TTCam2 data collection included 5 images of the Earth from each camera, 5 each of the Moon, and 5 each of both in the same frame. Figure 9 shows representative examples of some of the various Earth and Moon images taken during EGA1. The Moon images were used for primary validation of the radiometric coefficient derived in Section 2.8, and the Earth images provided a second set of less quantitative validation observations.

In order to enable the use of the Moon as a calibration and performance-verification target, we computed a model of the Lunar reflectance (I/F) expected under the illumination and viewing geometry conditions occurring during the time of EGA1. For this purpose, we used the spatially-resolved Hapke photometric parameter maps (Hapke, 2012) derived from multispectral observations by the Lunar Reconnaissance Orbiter Camera (LROC) (Sato et al., 2014). This photometric model covers the range $\pm 70^\circ$ in selenographic latitude, which corresponds to $\sim 94\%$ of the whole Lunar surface, or $\sim 98\%$ of the projected surface imaged by TTCam. The resolution of the model is $1^\circ \times 1^\circ$ in latitude and longitude, which is comparable to the range of pixel footprint sizes on the Moon in TTCam images obtained during the encounter. We used the model parameters at 604 nm, which is close to the ~ 535 nm effective center of the TTCam transmission band (Bell et al., 2023), to generate synthetic images of the Moon at the time of the encounter. Given the comparatively low spatial resolution of the model, the Moon was represented as a perfect sphere with a radius of 1737.4 km, thereby ignoring surface topography. For this reason, the model does not capture any shadows due to topography, but only photometric variations. The relevant photometric angles were computed for the times of exposure (phase angle of 80°) by using the NAIF SPICE environment (Acton, 1996).

We found a good correlation of the modeled lunar I/F values with the I/F values from the EGA1 data, as calibrated by the pre-flight radiometric calibration coefficients reported in Section 2.8. However, there was a systematic offset of about 30% for TTCam1 and 33% for TTCam2 between the modeled and observed measurements, likely due to systematic errors in the assumed component-level parameters of the cameras

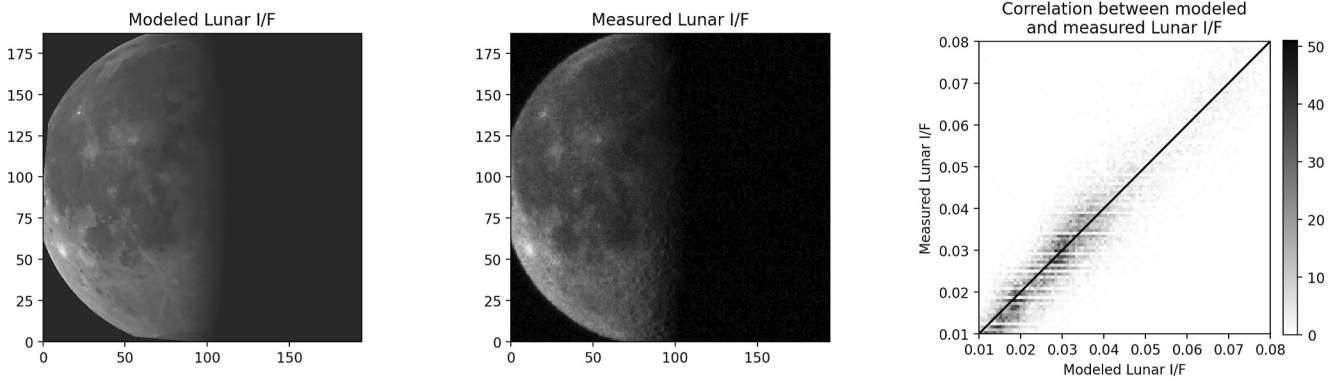

Figure 10. (left) Synthetic image of the Moon for the epoch 2022-10-16T14:45:00 UTC as seen from TTCam1. (middle) A representative observed in-flight TTCam1 image of the Moon, from the file `tc_0719216033_51253_eng_01_cal.fit`. (right) Correlation between modeled and calibrated I/F values of the Moon, as a histogram of the overlapping values.

(sensor quantum efficiency, filter and optics transmission) used in Section 2.8. When we apply that empirical correction factor to the radiometric calibration coefficient, the result is an excellent match between the modeled and observed lunar observations (Figure 10), with a Pearson correlation coefficient of $r = 0.96$ (92% agreement) for TTCam1 and $r = 0.95$ (89% agreement) for TTCam2. The resulting corrected radiometric calibration coefficients which we adopt for flight observations are $(1.8 \pm 0.3) \times 10^{-6} \left(\frac{s}{DN}\right) (\mu W/cm^2/nm/sr)$ for TTCam1 and $(1.9 \pm 0.3) \times 10^{-6} \left(\frac{s}{DN}\right) (\mu W/cm^2/nm/sr)$ for TTCam2. The averaged ratio between the modeled I/F values and our measured I/F values, calibrated with this radiometric coefficient, is 0.98 with a standard deviation of 0.16 for TTCam1, and 0.97 with a standard deviation of 0.18 for TTCam2. Thus, our analysis estimates the uncertainties on the absolute calibration of the TTCam images is approximately 15%–20%.

4.2.2. Exposure Time Modeling

Given the predicted reflectance and photometric properties of a target, we want to be able to estimate the DN and SNR of that target when imaged with TTCam. To do this, we created an exposure time model:

$$t_{\text{exp}} = (DN_{i,j} - B_{i,j} - D_{i,j}) \frac{r F_{i,j}}{\langle L_{\lambda} \rangle} \quad (23)$$

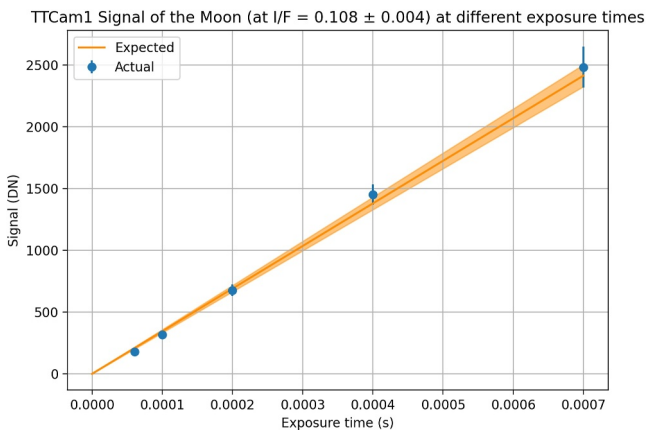

Figure 11. Exposure time model predictions (solid line) for a typical lunar highlands region with $I/F = 0.108$ at 1 AU, plotted against the actual raw DN levels (blue data points) from EGA1 images of a highlands region of the Moon with a model-predicted $I/F = 0.108 \pm 0.004$ (see Section 4.2.1). The differences between the model-predicted I/F and the actual raw DN levels is partly the result of a difference in resolution between the model and the actual data. The shaded orange region shows the range of expected signal values due the error in predicted I/F.

where r is the refined radiometric calibration coefficient (see Section 4.2.1) and the other variables are as defined above. The EGA1 images gave us the opportunity to validate this exposure time model. Figure 11, for example, shows the modeled and actual signal levels from EGA1 images of the Moon. For good signal levels below nonlinearity and saturation the exposure time model appears to slightly over-predict the actual raw DN levels of the target, making the model, perhaps appropriately, somewhat conservative against saturation.

4.3. Point Source Observations: Linearity and Radiometric Stability

Analysis, including aperture photometry, of a variety of stellar fields observed during cruise so far (e.g., Figure 7) confirms that the extended source linearity behavior described earlier in Section 2.1 is also valid for point sources observed in flight. Qualitative analysis of a series of these kinds of star observations during cruise so far does not reveal any changes in the signal levels of stars of similar magnitudes over time. More quantitative analyses of radiometric stability are in progress and will be reported in future work once the observations span a longer range of time.

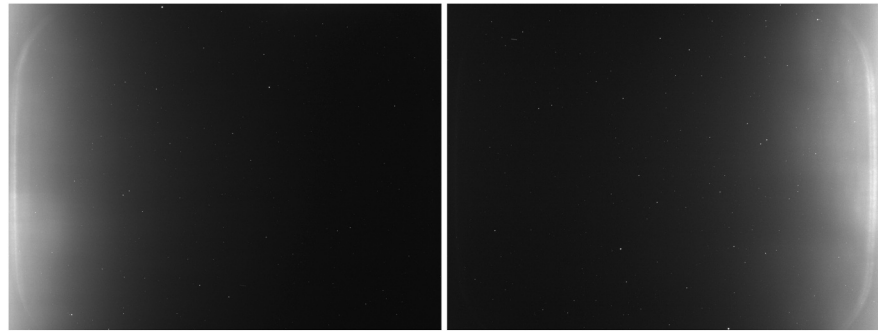

Figure 12. Example worst-case (30 s exposure time) stray/scattered sunlight behavior of TTCam1 (left) and TTCam2 (right) while viewing at an elongation of just 54° from the Sun, the most stressing sunward viewing geometry of any of the planned Lucy mission's Trojan flybys. The maximum signal here is approximately 100 DN/s; see text for details. The scattered light is coming from the same direction for both cameras, but appears on opposite sides of the fields of view here because TTCam2 is rotated by 180° on the spacecraft relative to TTCam1. The images were taken during flyby encounter simulation testing during cruise, in March, 2023.

4.4. Scattered Light Testing

On 28 March 2023, when the spacecraft was approximately 1.7 AU from the Sun, a series of Lucy payload observations was acquired while pointing the fields of view of the IPP instruments sunward, to simulate the viewing geometries of future eventual asteroid encounter observations (Olkin et al., 2021) and to search for potential scattered sunlight effects at the most challenging expected Solar Elongation Angles (SEAs; SEA = 0 would mean the Sun directly down the boresight). TTCam images were acquired at four different SEAs: 81° (simulating the viewing geometry on departure from the eventual Eurybates and Polymele flybys), 76° (Leucus approach), 66° (Dinkinesh approach), and 54° (Patroclus departure; the most stressing case for scattered light). Images at each SEA were acquired at both the short exposure times expected to be used during the flybys (30 ms and less), as well as at the longest-possible TTCam exposure time of 30 s. Analysis of the images reveals no significant ghosts and only a faint linear brightness pattern on one edge of the TTCam FOV that appears to result from scattered sunlight reflecting off the lip of the aperture opening in the TTCam sunshade (see Figure 1 above, and Figure 12). The diffuse signal and semi-curved bright structures at the far left and right edges of the fields of view represent sunlight scattered off the nearby L'LORRI telescope's blanketing and then off the lip of the aperture in each camera's sunshade and onto the sensor (see Bell et al., 2023 Figures 3, 7, and 8 for details). In the 30-s exposures from the most stressing case of SEA = 54° , the max scattered light signal is 3000 DN in the raw data, corresponding to 100 DN/s. The scattered light signal is even lower as the Sun moves even farther off the boresight at larger SEAs. Thus, at the typical expected 1–30 ms exposure times that will be used for imaging of the Trojan targets, the worst-case scattered light signal is expected to be between only 0–3 DN (<0.1% of full well), and spatially confined to one edge of the FOV.

4.5. Geometric Distortion

In order to use the TTCams for optical navigation, their focal length and geometric distortion must be characterized and calibrated. We used all available long-exposure images from the Launch+20 days and Launch+120 days calibration campaign observations. Due to a lack of images at varying temperatures, we were unable to estimate a temperature dependence of the TTCam focal lengths. We aim to characterize this temperature dependency as more images at colder temperatures become available as Lucy travels into the outer solar system. In lieu of the UCAC4 star catalog described in Bos et al. (2020), the TTCam focal length and geometric distortion calibrations utilized the Gaia star catalog, which contains significantly more stars and is intrinsically more accurate.

We used the OpenCV distortion model to represent the distortion across the field (OpenCV, 2014). More information on how the OpenCV distortion model was used to estimate the focal length and geometric distortion can

be found in Sections 7.2 and 7.5 of Bos et al. (2020). The analytical formulation for the OpenCV model is constructed using the following equations.

A vector in inertial space, v_I , is first transformed into the frame of the image using the rotation matrix C_{image}^I such that

$$v_{image} = [C_{image}^I]^T v_I \quad (24)$$

where v_{image} is the resulting vector in the image frame with origin at the OpNav defined intersection of the boresight and of the imager. This boresight location serves as the origin of the image frame axes within the OpNav process.

The resulting vector is then projected into the image plane using the equation

$$\begin{bmatrix} x_0 \\ y_0 \end{bmatrix} = \frac{1}{|v_{image,z}|} \begin{bmatrix} v_{image,x} \\ v_{image,y} \end{bmatrix}$$

where x_0 and y_0 are the resulting image plane coordinates in the x- and y-dimensions, relative to an origin at the boresight intersection.

The geometric optical distortion is then applied using the equations

$$r^2 = x_0^2 + y_0^2$$

$$\begin{bmatrix} x \\ y \end{bmatrix} = \begin{bmatrix} x_0 & 2x_0 y_0 & r^2 + 2x_0^2 \\ y_0 & r^2 + 2y_0^2 & 2x_0 y_0 \end{bmatrix} \begin{bmatrix} \frac{1 + k_1 r^2 + k_2 r^4 + k_3 r^6}{1 + k_4 r^2 + k_5 r^2 + k_6 r^2} \\ p_1 \\ p_2 \end{bmatrix}$$

where x and y are the distorted image plane coordinates. The $k_{1...6}$ coefficients correspond to the radial distortion of the optical system, and the $p_{1,2}$ coefficients correspond to the tangential distortion.

The final distorted sample and line coordinates are then calculated using the equation

$$\begin{bmatrix} u \\ v \end{bmatrix} = \begin{bmatrix} f_x(1 + a_1 T)x \\ f_y(1 + a_1 T)y \end{bmatrix} + \begin{bmatrix} c_x \\ c_y \end{bmatrix}$$

where T is the camera temperature in degrees Celsius, and u and v are the distorted sample and line coordinates in units of pixels. The values f_x and f_y refer to the focal lengths of the imager along the x- and y-dimensions in units of pixels at a camera temperature of 0°C. The value a_1 is a parameter to model the temperature dependence of the focal lengths. The $k_{1,2,3}$, $p_{1,2}$, f_x , and f_y values are estimated parameters in the calibration solution. The values c_x and c_y refer to the sample and line coordinates of the OpNav defined boresight of the system in units of pixels and in the OpNav coordinate system. For simplicity, we do not estimate the true optical axis for TTCam, so the fixed boresight definition is used for any and all values reported. The data to estimate a_1 will be collected during the mission's long cruise out to 5 AU; thus the solved-for parameters here reflect only the thermal conditions of the L+120 imaging activities. The remaining k_i terms are not estimated; heritage from past missions has shown that the set of coefficients used is sufficient for a precise distortion model of the instrument.

4.5.1. Geometric Distortion Calibration Results

A geometric distortion model using the OpenCV distortion model (OpenCV, 2014) was generated using a total of 2978 imaged stars for TTCam1 and 4323 imaged stars for TTCam2. The camera parameters and distortion coefficients are provided below in Table 5. Maps of the distortion solution on the FOVs are shown in Figures 13 and 14, which also shows pre- and post-fit star-center residuals in order to visualize the extent to which each model

Table 5
Estimated Camera Parameters and Distortion Coefficients for TTCam1 and TTCam2 Using the OpenCV Distortion Model

Camera parameter	Value	Coefficient	Value
TTCam1			
f_x (pixels)	13,448.168	k_1	1.074e−01
f_y (pixels)	13,447.850	k_2	3.641e−01
c_x	1296.5	k_3	5.287e−02
c_y	972.5	p_1	−4.641e−04
a_1	0	p_2	−3.310e−04
TTCam2			
f_x (pixels)	13,498.412	k_1	7.760e−02
f_y (pixels)	13,497.884	k_2	2.275
c_x	1296.5	k_3	2.566e−02
c_y	972.5	p_1	5.841e−04
a_1	0	p_2	8.625e−04

matches the optical data. Residuals are shown versus magnitude, as well as versus pix position and versus line position, and as scatter-quiver plots on the FOV.

The initial pre-fit quiver plot suggests the camera modeling errors are dominated by the focal length error and radial errors near the corners, but the post-fit residuals in Figures 13 and 14 show only a hint of remaining structure near the corners.

As expected, while the pre-distortion-fit residuals have non-zero means on the order of a tenth of a pixel, the standard deviation of those residuals is quite large, on the order of a few pixels for TTCam1 and about one-half of one pixel for TTCam2. After the distortion model converged, the post-fit residuals displayed near zero means and a standard deviation of under a tenth of a pixel for TTCam1 and one-tenth of a pixel for TTCam2. Though this is not the final calibration activity or model, these statistics suggest that the current camera model is already robust. There is no expected impact on terminal tracking or the science objectives due to geometric distortion.

4.5.2. Geometric Distortion Comparison

A close examination of the various pre-fit plots of the TTCams will show differences in the various characteristics of the imagers prior to the distortion calibration solution being applied.

Notably, a comparison of top-middle pre-distortion-fit plots in Figures 13 and 14 shows that the pre-fit behavior of the imagers differ greatly. While both instruments show similar pre-fit residual means, the standard deviation of those residuals is almost an order of magnitude higher for TTCam1 compared to TTCam2. Additionally, TTCam2 shows some of the correlation between residual and magnitude that we generally see in calibrated star residuals, while TTCam1 shows no such correlation and is dominated by the larger residuals. This is due to the larger focal length error in the TTCam1 a priori compared to TTCam2.

The two instruments show similar post-fit characterization, with very little structure evident in the residuals.

4.6. Point Spread Function

The TTCam Point Spread Function (PSF) was assessed using standard shift and add analysis of cruise star observations, as well as modeled assuming a Gaussian profile.

4.6.1. Shift and Add Stellar PSF Analysis

The TTCam PSFs were estimated using the “effective Point Spread Function” (ePSF) method developed by Anderson (2016) and Anderson and King (2000) and implemented in Astropy's Photutils Python package (Bradley et al., 2023). This method reports the effective averaged PSF across the entire focal plane. Provided a FITS image of a star field, the process begins with a null ePSF, identifies stars above a desired threshold, and iterates between the current star being evaluated and the developing ePSF. The process involves over-sampling the PSF by 4×, differencing between the current star and the developing ePSF, averaging and adjusting pixel residuals, smoothing, and re-centering over a user-provided N iterations with a final rescaling to 1× sampling. Visual inspection of stars identified is performed to remove hot pixels or stars that are too close to each other from consideration. We did not see any evidence of significant variations in the PSF across the FOV as part of the effective PSF determination. For TTCam1, 271 stars were identified and used to estimate the final PSF using this technique, and for TTCam2, 69 stars were used. Since TTCam2 has a more asymmetrical PSF than TTCam1 (see Figure 15 and Table 6), some fainter stars have lower enough signal levels in TTCam2 compared to TTCam1 that they did not reach our identified signal threshold for identifying stars.

Figure 15 provides a graphical representation of the derived PSFs for TTCam1 and TTCam2, respectively, and Table 6 provides the normalized (sum = 1.0) 7 × 7 pixel representations of those PSFs.

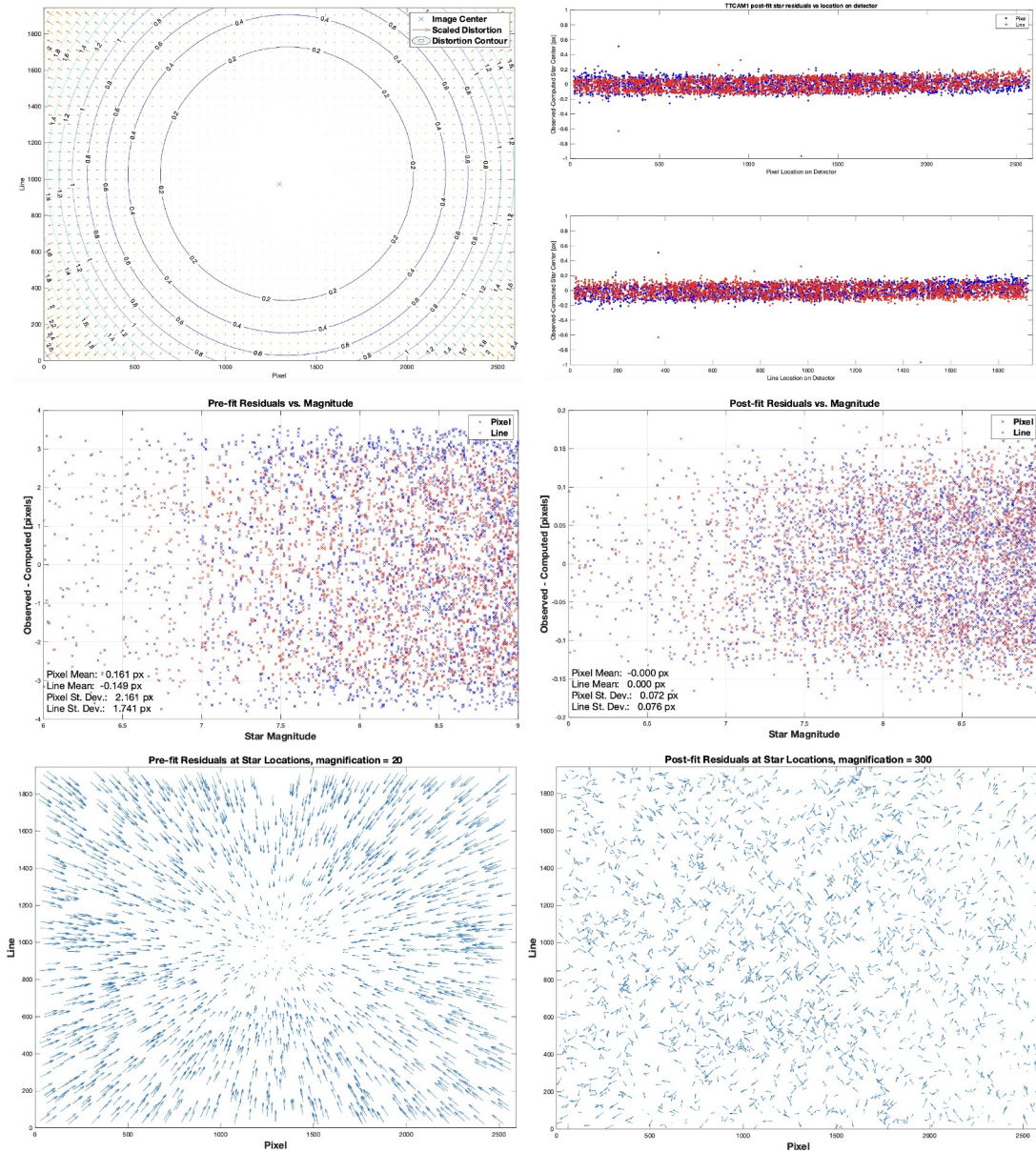

Figure 13. (top left) TTCam1 Post-calibration Optical Distortion Map. The contours show lines of constant distortion magnitude, and the quivers show direction and scaled magnitude of the distortion. (top right) Scatter plots of star center residuals for TTCam1 using the OpenCV distortion model. The top plot presents the residuals along the Pixel (horizontal) dimension of the FOV, and the bottom plot presents the residuals along the Line (vertical) dimension. (middle left) Pre-distortion-fit scatter plot of star center residuals versus star magnitude for TTCam1. (middle right) Post-distortion-fit scatter plot of star center residuals versus star magnitude for TTCam1. (bottom left) Pre-distortion-fit Quiver plot of star center residuals for TTCam1 using the OpenCV distortion model. The vector lengths have been multiplied 20× the actual residual value. (bottom right) Post-distortion-fit Quiver plot of star center residuals for TTCam1 using the OpenCV distortion model. The vector lengths have been multiplied 300× the actual residual value.

4.6.2. Gaussian PSF Modeling

The TTCam PSF was also modeled using the following generalized (rotated) 2D Gaussian function:

$$f(x,y) = Ae^{-[(x-x_0)(y-y_0)]BSB^T} \begin{bmatrix} (x-x_0) \\ (y-y_0) \end{bmatrix} \quad (25)$$

where

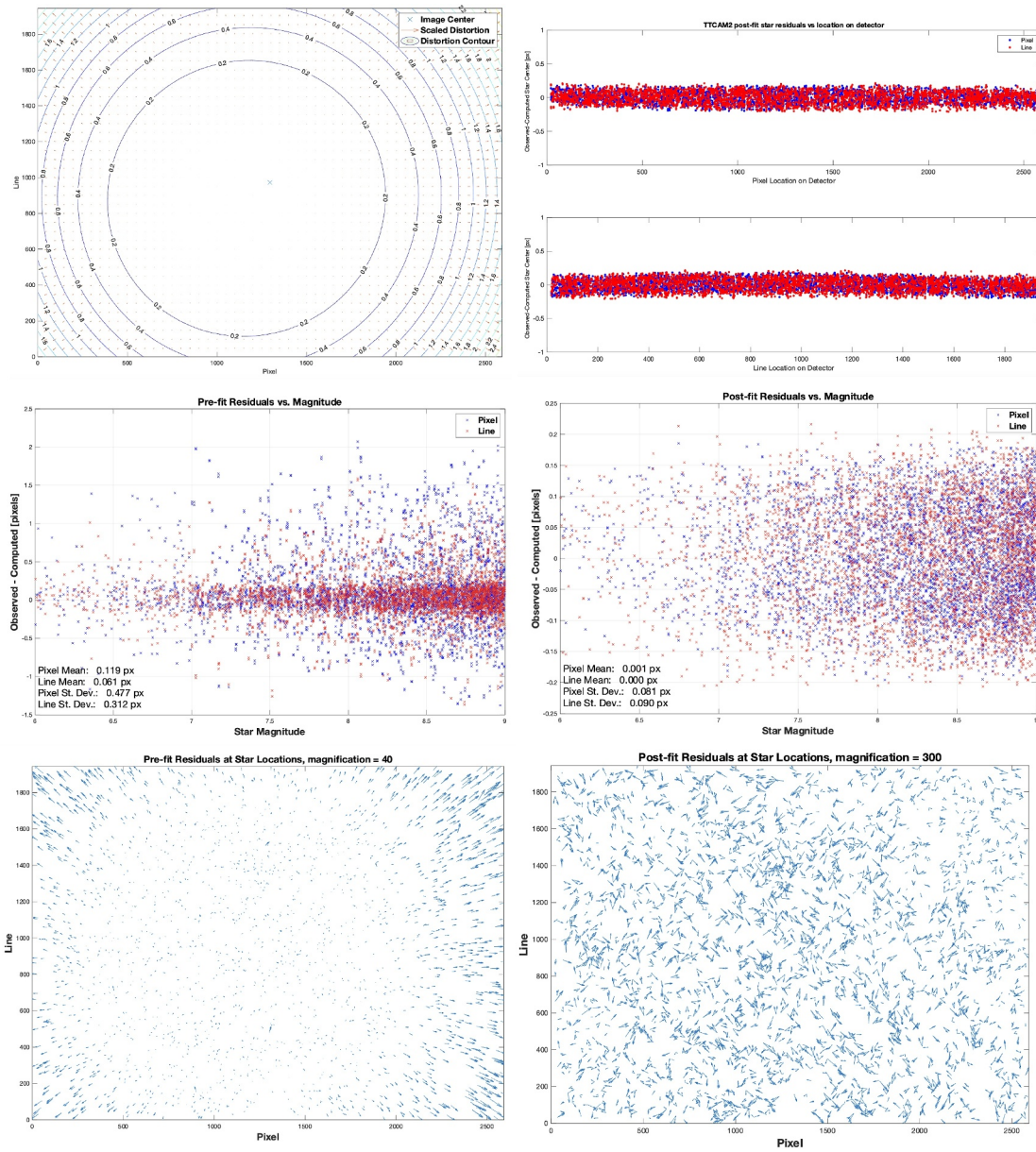

Figure 14. (top left) TTCam2 Post-calibration Optical Distortion Map. The contours show lines of constant distortion magnitude, and the quivers show direction and scaled magnitude of the distortion. (top right) Scatter plots of star center residuals for TTCam2 using the OpenCV distortion model. The top plot presents the residuals along the Pixel (horizontal) dimension of the FOV, and the bottom plot presents the residuals along the Line (vertical) dimension. (middle left) Pre-distortion-fit scatter plot of star center residuals versus star magnitude for TTCam2. (middle right) Post-distortion-fit scatter plot of star center residuals versus star magnitude for TTCam2. (bottom left) Pre-distortion-fit Quiver plot of star center residuals for TTCam2 using the OpenCV distortion model. The vector lengths have been multiplied 40× the actual residual value. (bottom right) Post-distortion-fit Quiver plot of star center residuals for TTCam2 using the OpenCV distortion model. The vector lengths have been multiplied 300× the actual residual value.

$$B = \begin{bmatrix} \cos(\theta) & -\sin(\theta) \\ \sin(\theta) & \cos(\theta) \end{bmatrix}$$

$$S = \begin{bmatrix} \frac{1}{\sigma_x^2} & 0 \\ 0 & \frac{1}{\sigma_y^2} \end{bmatrix}$$

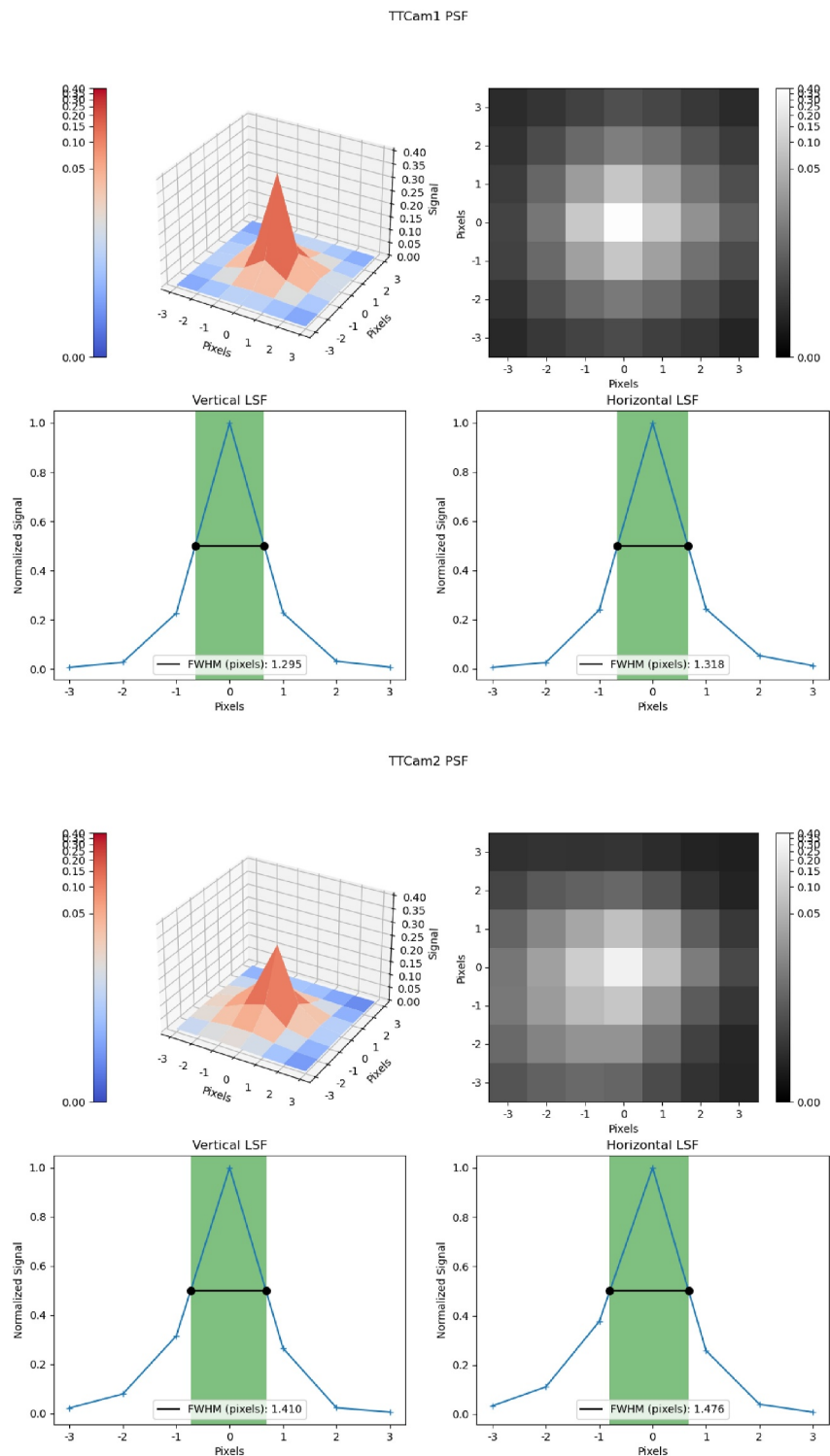

Figure 15. (top four) Estimated Point Spread Function (PSF) for TTCam1 using the “Shift and Add” approach described in the text. Representative vertical and horizontal Line Scan Functions (LSFs) are shown, revealing an average FWHM of the PSF of 1.30 pixels. (bottom four) Estimated PSF for TTCam2 using the “Shift and Add” approach described in the text. The graphs, image, and data in Table 6 show that TTCam2 has a broader and more skewed PSF than TTCam1, with an average FWHM of the PSF of 1.44 pixels.

Table 6
TTCam Normalized Point Spread Functions (PSF)

TTCam1 PSF central 7×7 pixels, normalized							
	-3	-2	-1	0	1	2	3
-3	0.001	0.001	0.002	0.003	0.002	0.001	0.001
-2	0.001	0.003	0.007	0.010	0.007	0.003	0.001
-1	0.002	0.006	0.030	0.084	0.030	0.008	0.003
0	0.002	0.009	0.088	0.370	0.090	0.020	0.005
1	0.002	0.006	0.027	0.084	0.031	0.009	0.003
2	0.001	0.003	0.007	0.012	0.008	0.003	0.002
3	0.001	0.001	0.002	0.003	0.002	0.001	0.001
TTCam2 PSF central 7×7 Pixels, normalized							
	-3	-2	-1	0	1	2	3
-3	0.004	0.005	0.007	0.006	0.003	0.001	0.001
-2	0.007	0.014	0.022	0.021	0.007	0.002	0.001
-1	0.010	0.026	0.063	0.085	0.021	0.004	0.001
0	0.009	0.030	0.102	0.271	0.070	0.011	0.002
1	0.006	0.015	0.036	0.072	0.030	0.005	0.002
2	0.002	0.004	0.005	0.006	0.003	0.001	0.001
3	0.001	0.001	0.001	0.001	0.001	0.001	0.001

A is the amplitude of the PSF, (x_0, y_0) is the center of the PSF, θ is the angle between the image X -axis and the principal axis of the Gaussian, σ_x is the Gaussian RMS width in the semi-major axis direction, and σ_y is the Gaussian RMS width in the semi-minor axis direction.

This Gaussian function was fit to the PSFs of 4361 stars in TTCam1 images and 2684 stars in TTCam2 images to evaluate and characterize the PSF of the two imagers. Only stars with a peak signal between 500 and 3500 DN were selected to avoid stars with a low signal-to-noise ratio as well as saturated stars. For TTCam1, the mean semi-major axis width was 0.599 ± 0.064 pixels and the mean semi-minor axis width was 0.507 ± 0.063 pixels. The rotation angles seemed mostly random for TTCam1 but most star PSFs had rotation angles between 90° and 180° , as seen in Figure 16. For TTCam2, the mean semi-major axis width was 0.757 ± 0.166 pixels and the mean semi-minor axis width was 0.574 ± 0.128 pixels. Most TTCam2 star PSFs had rotation angles between roughly 120° and 170° , as seen in Figure 16.

5. Conclusions

This paper details the pre-flight and in-flight calibration of the Lucy mission's TTCam instruments, in support of eventual scientific observations of the Trojan asteroids during flyby encounters. We find that both sensors exhibit excellent linearity (with a maximum deviation from fit $<2.2\%$), low read noise ($<15 e^-$), no statistically significant dark current at the expected operational temperatures, and uniform pixel-to-pixel

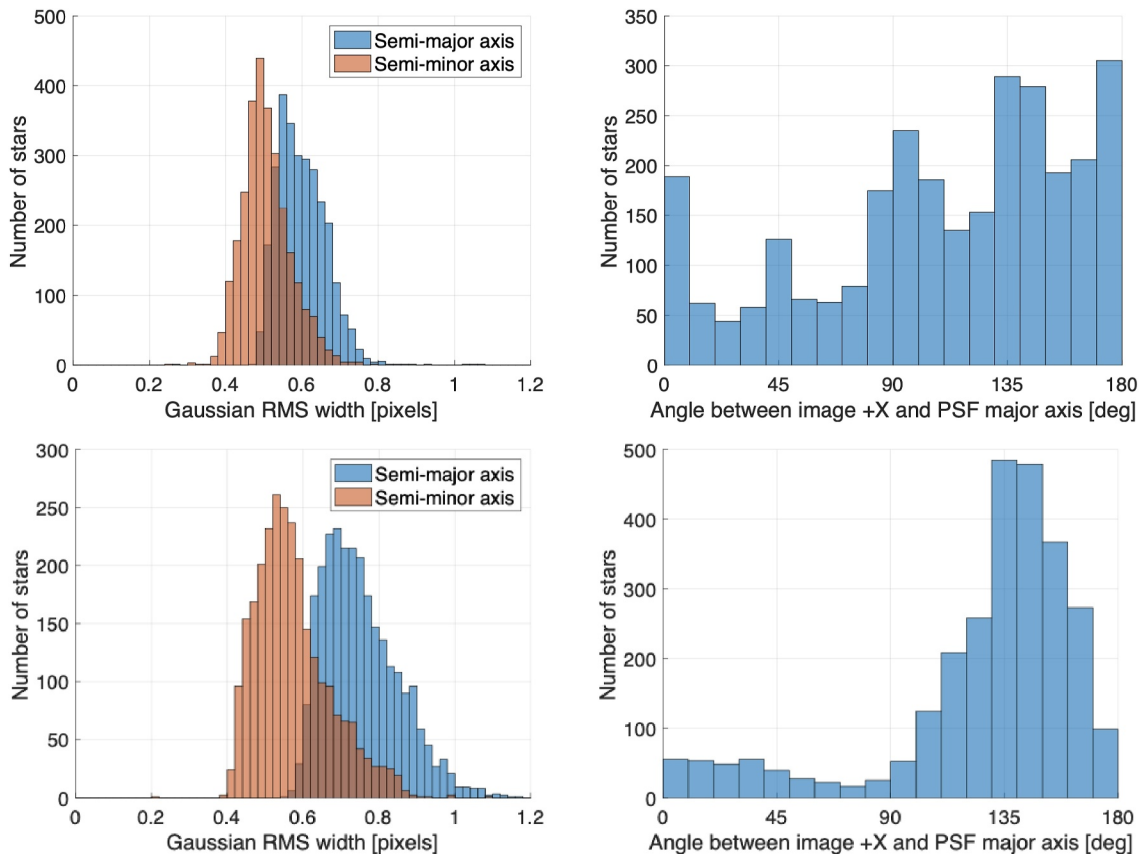

Figure 16. (top) Histograms of the fitted Gaussian widths (left) and rotation angles (right) for 4361 stars in TTCam1 images. (bottom) Histograms of the fitted Gaussian widths (left) and rotation angles (right) for 2,684 stars in TTCam2 images.

responsivity variations of <2.5%. In-flight observations provide additional confirmation of instrument performance and characteristics, including: (a) Observations of star fields that confirm extremely little geometric distortion across the FOV; (b) Observations of the Earth and Moon that refine pre-flight expectations of the absolute radiometry of the cameras to within 15%; and (c) Observations of scattered sunlight at the viewing geometries of the eventual asteroid encounters that show that scattered light levels should be insignificant compared to signal from the targets.

We have used the pre-flight and in-flight calibration information to develop an exposure time model, used to determine commanded Terminal Tracking and science exposures of the Trojans at closest approach, as well as a calibration pipeline that converts each raw TTCam image to calibrated radiance and radiance factor, including associated uncertainty images for those derived parameters and a bad pixel image that flags any saturated or nonlinear pixels. We present details on the ancillary input files and parameters needed to run the pipeline, as well as the output FITS format calibrated data files and their associated ancillary data. Additional information on the measurement requirements, design, and expected scientific results from the TTCam instruments is provided in a companion paper by Bell et al. (2023).

Appendix A: TTCam Predicted Pre-Flight Optical Specifications

See Figure A1 and Table A1.

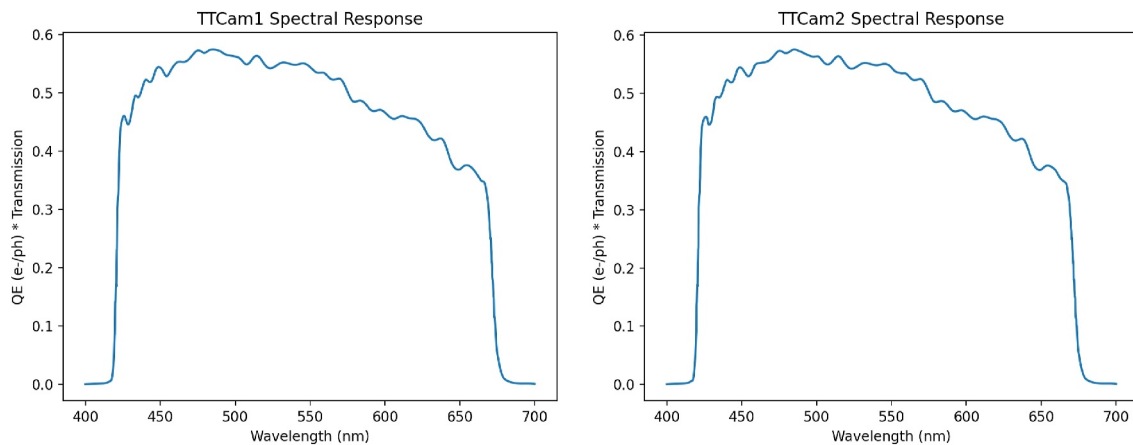

Figure A1. Spectral response of the two cameras.

Table A1

Lucy Mission Terminal Tracking Cameras: Pre-Flight Optical Specifications

Focal length	29.7 mm (all-refractive; fixed focus)
Focal ratio	f/2.95
Depth of field	≈200 m to ∞ (hyperfocal: 133.7 m; near-focus: 66.8 m)
Entrance pupil aperture	9.9 mm
Aperture area	77 mm ²
Exit pupil diameter	7.1 mm
Optics transmission	>80%
T/# = [(f/#)/sqrt(transmission)]	<3.36
Pixel solid angle	5.5 × 10 ⁻⁹ sr
Throughput (A ₀ Ω)	4.22 × 10 ⁻⁷ mm ² sr
IIFOV	74.1 μrad/pixel (74.1 m/pixel @ 1,000 km)
FOV	11.0° × 8.2° (13.7° diagonal) (193 × 143 km @ 1,000 km)
Filters	1
Filter bandpass	Panchromatic: 425–675 nm
Effective wavelength	Avg. Red Trojan: 548.6 nm; Avg. Less-Red Trojan: 545.5 nm
Optics distortion	0.12% average in corners of field of view
MTF (TTCam1)	0.16 (optics + filter + sensor) at Nyquist = 227 l.p./mm
MTF (TTCam2)	0.14 (optics + filter + sensor) at Nyquist = 227 l.p./mm

Appendix B: Lucy TTCam Default Square-Root Companding (12–8 Bit DN) “Mode 17” Lookup Table

Original raw 12-bit range	Downlinked 8-bit DN	12-bit	8-bit	12-bit	8-bit	12-bit	8-bit	12-bit	8-bit	12-bit	8-bit	12-bit	8-bit	12-bit	8-bit
0	0	69–73	32	265–272	64	587–598	96	1035–1050	128	1611–1630	160	2313–2336	192	3141–3168	224
1	1	74–77	33	273–280	65	599–610	97	1051–1066	129	1631–1650	161	2337–2360	193	3169–3197	225
2	2	78–81	34	281–288	66	611–622	98	1067–1083	130	1651–1670	162	2361–2384	194	3198–3225	226
3	3	82–86	35	289–297	67	623–635	99	1084–1099	131	1671–1690	163	2385–2408	195	3226–3253	227
4	4	87–91	36	298–306	68	636–647	100	1100–1116	132	1691–1711	164	2409–2433	196	3254–3281	228
5	5	92–95	37	307–314	69	648–660	101	1117–1132	133	1712–1732	165	2434–2457	197	3282–3310	229
6	6	96–100	38	315–323	70	661–673	102	1133–1149	134	1733–1752	166	2458–2482	198	3311–3339	230
7	7	101–105	39	324–332	71	674–686	103	1150–1166	135	1753–1773	167	2483–2507	199	3340–3368	231
8	8	106–111	40	333–341	72	687–699	104	1167–1183	136	1774–1794	168	2508–2532	200	3369–3396	232
9	9	112–116	41	342–351	73	700–712	105	1184–1200	137	1795–1815	169	2533–2557	201	3397–3426	233
10	10	117–121	42	352–360	74	713–725	106	1201–1218	138	1816–1837	170	2558–2582	202	3427–3455	234
11	11	122–127	43	361–370	75	726–739	107	1219–1235	139	1838–1858	171	2583–2608	203	3456–3484	235
12–13	12	128–133	44	371–379	76	740–752	108	1236–1253	140	1859–1879	172	2609–2633	204	3485–3513	236
14–14	13	134–138	45	380–389	77	753–766	109	1254–1270	141	1880–1901	173	2634–2659	205	3514–3543	237
15–16	14	139–144	46	390–399	78	767–780	110	1271–1288	142	1902–1923	174	2660–2684	206	3544–3573	238
17–18	15	145–150	47	400–409	79	781–794	111	1289–1306	143	1924–1945	175	2685–2710	207	3574–3602	239
19–21	16	151–156	48	410–419	80	795–808	112	1307–1324	144	1946–1967	176	2711–2736	208	3603–3632	240
22–23	17	157–163	49	420–429	81	809–822	113	1325–1342	145	1968–1989	177	2737–2762	209	3633–3662	241

Table
Continued

24–25	18	164–169	50	430–439	82	823–837	114	1343–1360	146	1990–2011	178	2763–2789	210	3663–3693	242
26–28	19	170–176	51	440–450	83	838–851	115	1361–1379	147	2012–2034	179	2790–2815	211	3694–3723	243
29–31	20	177–182	52	451–461	84	852–866	116	1380–1397	148	2035–2056	180	2816–2841	212	3724–3753	244
32–34	21	183–189	53	462–471	85	867–880	117	1398–1416	149	2057–2079	181	2842–2868	213	3754–3784	245
35–36	22	190–196	54	472–482	86	881–895	118	1417–1435	150	2080–2101	182	2869–2895	214	3785–3814	246
37–40	23	197–203	55	483–493	87	896–910	119	1436–1454	151	2102–2124	183	2896–2921	215	3815–3845	247
41–43	24	204–210	56	494–504	88	911–925	120	1455–1473	152	2125–2147	184	2922–2948	216	3846–3876	248
44–46	25	211–217	57	505–516	89	926–940	121	1474–1492	153	2148–2170	185	2949–2975	217	3877–3907	249
47–49	26	218–225	58	517–527	90	941–956	122	1493–1511	154	2171–2194	186	2976–3003	218	3908–3938	250
50–53	27	226–232	59	528–538	91	957–971	123	1512–1531	155	2195–2217	187	3004–3030	219	3939–3970	251
54–57	28	233–240	60	539–550	92	972–987	124	1532–1550	156	2218–2240	188	3031–3057	220	3971–4001	252
58–61	29	241–248	61	551–562	93	988–1002	125	1551–1570	157	2241–2264	189	3058–3085	221	4002–4033	253
62–64	30	249–256	62	563–573	94	1003–1018	126	1571–1590	158	2265–2288	190	3086–3113	222	4034–4064	254
65–68	31	257–264	63	574–586	95	1019–1034	127	1591–1610	159	2289–2312	191	3114–3140	223	4065–4095	255

Appendix C: Lucy TTCam Default Square-Root Decompaning (8–12 Bit DN) “Mode 17” Lookup Table

8-bit	12-bit	8-bit	12-bit	8-bit	12-bit	8-bit	12-bit	8-bit	12-bit	8-bit	12-bit	8-bit	12-bit	8-bit	12-bit
0	0	32	71	64	268	96	592	128	1042	160	1620	192	2324	224	3154
1	1	33	75	65	276	97	604	129	1058	161	1640	193	2348	225	3183
2	2	34	79	66	284	98	616	130	1075	162	1660	194	2372	226	3211
3	3	35	84	67	293	99	629	131	1091	163	1680	195	2396	227	3239
4	4	36	89	68	302	100	641	132	1108	164	1701	196	2421	228	3267
5	5	37	93	69	310	101	654	133	1124	165	1722	197	2445	229	3296
6	6	38	98	70	319	102	667	134	1141	166	1742	198	2470	230	3325
7	7	39	103	71	328	103	680	135	1158	167	1763	199	2495	231	3354
8	8	40	108	72	337	104	693	136	1175	168	1784	200	2520	232	3382
9	9	41	114	73	346	105	706	137	1192	169	1805	201	2545	233	3411
10	10	42	119	74	356	106	719	138	1209	170	1826	202	2570	234	3441
11	11	43	124	75	365	107	732	139	1227	171	1848	203	2595	235	3470
12	12	44	130	76	375	108	746	140	1244	172	1869	204	2621	236	3499
13	14	45	136	77	384	109	759	141	1262	173	1890	205	2646	237	3528
14	15	46	141	78	394	110	773	142	1279	174	1912	206	2672	238	3558
15	17	47	147	79	404	111	787	143	1297	175	1934	207	2697	239	3588
16	20	48	153	80	414	112	801	144	1315	176	1956	208	2723	240	3617
17	22	49	160	81	424	113	815	145	1333	177	1978	209	2749	241	3647
18	24	50	166	82	434	114	830	146	1351	178	2000	210	2776	242	3678
19	27	51	173	83	445	115	844	147	1370	179	2023	211	2802	243	3708
20	30	52	179	84	456	116	859	148	1388	180	2045	212	2828	244	3738
21	33	53	186	85	466	117	873	149	1407	181	2068	213	2855	245	3769

Table
Continued

22	35	54	193	86	477	118	888	150	1426	182	2090	214	2882	246	3799
23	38	55	200	87	488	119	903	151	1445	183	2113	215	2908	247	3830
24	42	56	207	88	499	120	918	152	1464	184	2136	216	2935	248	3861
25	45	57	214	89	510	121	933	153	1483	185	2159	217	2962	249	3892
26	48	58	221	90	522	122	948	154	1502	186	2182	218	2989	250	3923
27	51	59	229	91	533	123	964	155	1521	187	2206	219	3017	251	3954
28	55	60	236	92	544	124	979	156	1541	188	2229	220	3044	252	3986
29	59	61	244	93	556	125	995	157	1560	189	2252	221	3071	253	4017
30	63	62	252	94	568	126	1010	158	1580	190	2276	222	3099	254	4049
31	66	63	260	95	580	127	1026	159	1600	191	2300	223	3127	255	4080

Data Availability Statement

All calibration data from pre-calibration activities, as well as ancillary calibration files such as flat fields and bad pixel maps, are available at the ASU Library Research Data Repository, at <https://doi.org/10.48349/ASU/RVHF83> (Bell & Zhao, 2023). All in-flight data taken with the TTCams used for validation of the calibration pipeline are or will soon be archived in the NASA Planetary Data System for full public dissemination (found at https://pds-smallbodies.astro.umd.edu/data_sb/missions/lucy/index.shtml).

Acknowledgments

We would like to thank all the members of the Lucy mission team, including the MSSS staff, the Lockheed Martin support staff, NASA support staff, and the subcontractors and vendors, who supported the Lucy mission through unpredictable hardships, including a global pandemic. In addition, we would like to thank Danielle Smilovsky and Oketa Basha of Arizona State University for their work on the TTCam calibration pipeline and in-flight star observations, respectively. The work performed here by researchers at Arizona State University was supported by the NASA Lucy mission, via subcontract #K99056JRG from the Southwest Research Institute.

References

- Acton, C. H. (1996). Ancillary data services of NASA's navigation and ancillary information facility. *Planetary and Space Science*, *44*(1), 65–70. [https://doi.org/10.1016/0032-0633\(95\)00107-7](https://doi.org/10.1016/0032-0633(95)00107-7)
- Anderson, J. (2016). Empirical models for the WFC3/IR PSF. *Instrument Science Report WFC3 2016-12*, 42.
- Anderson, J., & King, I. R. (2000). Toward high-precision astrometry with WFPC2. I. Deriving an accurate point-spread function. *PASP*, *112*(776), 1360–1382. <https://doi.org/10.1086/316632>
- Bell, J., Godber, A., McNair, S., Caplinger, M., Maki, J., Lemmon, M., et al. (2017). The Mars Science Laboratory Curiosity rover Mastcam instruments: Preflight and in-flight calibration, validation, and data archiving. *Earth and Space Science*, *4*(7), 396–452. <https://doi.org/10.1002/2016EA000219>
- Bell, J., & Zhao, A. (2023). Lucy Terminal Tracking Camera (TTCam) pre-flight calibration data [Dataset]. *ASU Library Research Data Repository*. <https://doi.org/10.48349/ASU/RVHF83>
- Bell, J., Zhao, Y., Cisneros, E., Beasley, M., Olkin, C., Caplinger, M. A., et al. (2023). The terminal tracking camera system on the NASA Lucy Trojan Asteroid Discovery mission. *Space Science Reviews*, *219*(8), 86. <https://doi.org/10.1007/s11214-023-01030-5>
- Bos, B. J., Nelson, D. S., Pelgrift, J. Y., Liounis, A. J., Doelling, D., Norman, C. D., et al. (2020). In-flight calibration and performance of the OSIRIS-REx touch and go camera system (TAGCAMS). *Space Science Reviews*, *216*(4), 71. <https://doi.org/10.1007/s11214-020-00682-x>
- Bradley, L., Sipőcz, B., Robitaille, T., Tollerud, E., Vinicius, Z., Deil, C., et al. (2023). *astropy/photutils: 1.8.0*. *Zenodo*. <https://doi.org/10.5281/zenodo.7946442>
- Colina, L., Bohlin, R. C., & Castelli, F. (1996). The 0.12–2.5 micron absolute flux distribution of the sun for comparison with solar analog stars. *Astronomical Journal*, *112*, 307. <https://doi.org/10.1086/118016>
- Good, P., Faiks, P., & Pisano, W. (2022). Terminal tracking for the Lucy Trojan asteroid mission. In *44th Annual AAS Guidance, Navigation and Control Conference*. Retrieved from <https://ntrs.nasa.gov/api/citations/20220001851/downloads/AAS-22-131TerminalTrackingfortheLucyTrojanAsteroidMission.pdf>
- Hapke, B. (2012). *Theory of reflectance and emittance spectroscopy* (2nd ed.). Cambridge University Press. <https://doi.org/10.1017/CBO9781139025683>
- Janesick, J., Klaasen, K. P., & Elliott, T. S. (1987). Charge-coupled-device charge-collection efficiency and the photon-transfer technique. *Optical Engineering*, *26*(10), 972–980. <https://doi.org/10.1117/12.7974183>
- Levison, H. F., Olkin, C. B., Noll, K. S., Marchi, S., BellIII, J. F., Bierhaus, E., et al. (2021). Lucy mission to the Trojan asteroids: Science goals. *The Planetary Science Journal*, *2*(5), 171. <https://doi.org/10.3847/psj/abf840>
- Malin, M. C., Edgett, K., Jensen, E., & Lipkaman, L. (2013). Mars science laboratory project software interface specification (SIS): Mast camera (Mastcam), Mars Hand lens imager (MAHLI), and Mars descent imager (MARDI) experiment data record (EDR), reduced data record (RDR), and PDS data products. *JPL D-75410*. Retrieved from http://pds-imaging.jpl.nasa.gov/data/msl/MSLMST_0001/DOCUMENT/MSL_MMM_EDR_RDR_DPSIS.PDF
- Olkin, C. B., Levison, H. F., Vincent, M., Noll, K. S., Andrews, J., Gray, S., et al. (2021). Lucy mission to the Trojan asteroids: Instrumentation and encounter concept of operations. *The Planetary Science Journal*, *2*(5), 172. <https://doi.org/10.3847/psj/abf83f>
- OpenCV. (2014). Camera calibration and 3d reconstruction [Software]. https://link.springer.com/chapter/10.1007/978-3-030-42378-0_7

- Sato, H., Robinson, M., Hapke, B., Denevi, B., & Boyd, A. (2014). 08). Resolved Hapke parameter maps of the Moon. *Journal of Geophysical Research: Planets*, 119(8), 1775–1805. <https://doi.org/10.1002/2013JE004580>
- Shkarin, D. A. (2001). Improving the efficiency of the PPM algorithm. *Problems of Information Transmission*, 37(3), 226–235. <https://doi.org/10.1023/a:1013878007506>
- Spencer, J. R., Bell, J. F., III, Christensen, P. R., Dello Russo, N., Kaplan, H. H., Reuter, D. C., et al. (2024). The first Lucy Earth flyby (EGA1). *Space Science Reviews*, 220(3), 3. <https://doi.org/10.1007/s11214023-01034-1>