

# LICIACube LEIA/LUKE Uncalibrated/Calibrated Data Software Interface Specification

Version 1

31<sup>st</sup> July 2023

Prepared by

Angelo Zinzi (ASI) – LICIACube SOC Lead

Vincenzo Della Corte (INAF) – LICIACube co-PI and Instrument Scientist

Revised by the LICIACube Team



1	Purpose and Scope .....	4
2	Applicable Documents and Constraints .....	4
3	Relationships with Other Interfaces .....	5
4	Data Product Characteristics and Environment .....	5
4.1	Instruments Overview .....	6
4.1.1	LEIA .....	6
4.1.2	LUKE .....	8
4.2	Data Product Overview.....	12
4.2.1	LICIACube LEIA Data Product Overview .....	12
4.2.2	LICIACube LUKE Data Product Overview .....	12
4.3	Data Processing .....	13
4.3.1	Data Processing Level .....	13
4.4	Data Product Generation.....	14
4.4.1	LICIACube LEIA Level-0 Raw Images .....	14
4.4.2	LICIACube LEIA Level-2 Calibrated Images .....	14
4.4.3	Data Flow .....	18
4.4.4	Labeling and Identification .....	18
4.5	Standards Used in Generating Data Products .....	19
4.5.1	PDS Standards.....	19
4.5.2	Time Standards .....	20
4.5.3	Coordinate Systems.....	20
4.5.4	Data Storage Conventions .....	20
4.5.5	Data Validation .....	20
5	Detailed Data Product Specification.....	20
5.1	Data Product Structure and Organization .....	20
5.2	Data Format Descriptions.....	21
5.2.1	LICIACube LEIA Raw Image Data.....	21
5.2.2	LICIACube LEIA Calibrated Image Data.....	27
5.2.3	LICIACube LEIA Raw Pixel Values.....	28
5.2.4	LICIACube LEIA Calibration File Formats .....	28
5.2.5	LICIACube LUKE Raw Image Data .....	29
5.2.6	LICIACube LUKE Calibrated Image Data.....	35
5.2.7	LICIACube LUKE Raw Pixel Values.....	36
5.2.8	LICIACube LUKE Calibration File Formats .....	36
5.3	Label and Header Descriptions.....	37

6 Applicable Software..... 37

7 Appendices ..... 38

7.1 Appendix 1: List of acronyms..... 38

# 1 Purpose and Scope

The data products described by this Software Interface Specification (SIS) are the reconstructed images from telemetry (raw), calibrated and derived images from the LICIAcube (LCC) LEIA (Liciacube Explorer Imaging for Asteroid) and LUKE (Liciacube Unit Key Explorer) instruments. The LCC Science Operation Center (LSOC) located at the Space Science Data Center of the Italian Space Agency (SSDC-ASI) produces these data products, sharing them with the DART (Double Asteroid Redirection Test) Science Operation Center (SOC) that subsequently distributes them to the Planetary Data System (PDS).

The purpose of this document is to provide a detailed description of the data products, how they were generated, and how they are organized in the archive, including data sources and destinations. The document is intended to provide enough information to enable users to read and understand the data products. The users for whom this document is intended are the scientists who will analyse the data, including those associated with the DART and LICIAcube project and those in the general planetary science community.

## 2 Applicable Documents and Constraints

This LICIAcube data product SIS is consistent with the following Planetary Data System documents:

- Planetary Data System Standards Reference, Version 1.14.0, May 22, 2020
- PDS4 Data Dictionary, Abridged, Version 1.14.0.0, March 23, 2020
- PDS4 Information Model Specification, Version 1.14.0.0, March 23, 2020

This LICIAcube data product SIS is responsive to the following DART and LICIAcube project documents:

[AD1]. 7482-9060 Data Management and Archive Plan Double Asteroid Redirection Test (DART)

[AD2]. 7482-9168 LICIAcube and DART-SOC Interface Control Document (ICD)

[AD3]. Della Corte, V. & Zinzi, A., LICIAcube Explorer Imaging for Asteroid (LEIA) and LICIAcube Unit Key Explorer (LUKE) Calibration Pipeline Description

[AD4]. Didymos Reconnaissance and Asteroid Camera for OpNav (DRACO) Uncalibrated/Calibrated Data Product Software Interface Specification – Version 1.0

This LICIAcube data product SIS is consistent with the following documents:

1. Dotto, E., Della Corte, V., Amoroso, M., Bertini, I., Brucato, J.R., Capannolo, A., Cotugno, B., Cremonese, G., Di Tana, V., Gai, I., Ieva, S., Impresario, G., Ivanovski, S.L., Lavagna, M., Lucchetti, A., Mazzotta Epifani, E., Meneghin, A., Miglioretti, F., Modenini, D., Pajola, M., Palumbo, P., Perna, D., Pirrotta, S., Poggiali, G., Rossi, A., Simioni, E.,

- Simonetti, S., Tortora, P., Zannoni, M., Zanotti, G., Zinzi, A., Cheng, A.F., Rivkin, A.S., Adams, E.Y., Reynolds, E.L., Fretz, K., 2021. LICIACube - The Light Italian Cubesat for Imaging of Asteroids In support of the NASA DART mission towards asteroid (65803) Didymos. Planetary and Space Science 199, 105185.  
<https://doi.org/10.1016/j.pss.2021.105185>
2. Poggiali, G., Brucato, J. R., Hasselmann, P. H., Ieva, S., Perna, D., Pajola, M., Lucchetti, A., Deshapriya, J. D. P., Della Corte, V., Mazzotta Epifani, E., Rossi, A., Ivanovski, S. L., Zinzi, A., Meneghin, A., Amoroso, M., Pirrotta, S., Impresario, G., Dotto, E., Bertini, I., Capannolo, A., Cremonese, G., Cotugno, B., Dall’Ora, M., Di Tana, V., Gai, I., Lavagna, M., Miglioretti, F., Modenini, D., Palumbo, P., Simioni, E., Simonetti, S., Tortora, P., Zannoni, M., Zanotti, G., 2022, Expected Investigation of the (65803) Didymos–Dimorphos System Using the RGB Spectrophotometry Data Set from the LICIACube Unit Key Explorer (LUKE) Wide-angle Camera, The Planetary Science Journal, 3, 161,  
<https://doi.org/10.3847/PSJ/ac76c4>
  3. Menon, D., Andriani, S., & Calvagno, G., 2007, Demosaicing With Directional Filtering and a posteriori Decision, IEEE Transactions on Image Processing, 16(1), 132-141,  
doi:10.1109/TIP.2006.884928
  4. Della Corte, V. & Zinzi, A., LICIACube Explorer Imaging for Asteroid (LEIA) and LICIACube Unit Key Explorer (LUKE) Calibration Pipeline Description

### 3 Relationships with Other Interfaces

Changes to the data products described in this SIS may affect the documents listed in Table 1. In the event of a conflict between the LICIACube SIS and the LICIACube Explorer Imaging for Asteroid (LEIA) and LICIACube Unit Key Explorer (LUKE) Calibration Pipeline Description, the pipeline description takes precedence. In the event of a conflict between the LICIACube SIS and the DRACO DMAP, the DMAP takes precedence.

Table 1: Interface relationships

Name	Type	Owner
LICIACube Explorer Imaging for Asteroid (LEIA) and LICIACube Unit Key Explorer (LUKE) Calibration Pipeline Description	Document	LICIACube SOC

### 4 Data Product Characteristics and Environment

## 4.1 Instruments Overview

DART was a low-cost technology demonstration of the kinetic impactor technique to divert a hazardous asteroid. DART carried LICIACube, a 6U CubeSat, deployed 15 days before DART impacted Dimorphos, the moon of the asteroid Didymos, to image the impact and ejecta plume evolution thereafter.

The two spacecrafts have been launched from the Vandenberg Space Force Base, California, on 24<sup>th</sup> November 2021 using a Falcon 9 rocket and the impact between DART and Dimorphos occurred on 26<sup>th</sup> September 2022.

LICIACube has been deployed 15 days before the impact, subsequently starting its autonomous navigation, looking for Dimorphos, with a couple of communication windows per day until the date of the impact.

It started observing Dimorphos roughly 1 minute before the impact, acquiring images for about 15 minutes. After the end of this image collection phase, LICIACube communicated periodically with the DSN antennas to download the images until 24<sup>th</sup> October 2022. The total number of downloaded images was 426.

The LICIACube mission possesses two cameras, named LEIA and LUKE, here detailed:

### 4.1.1 LEIA

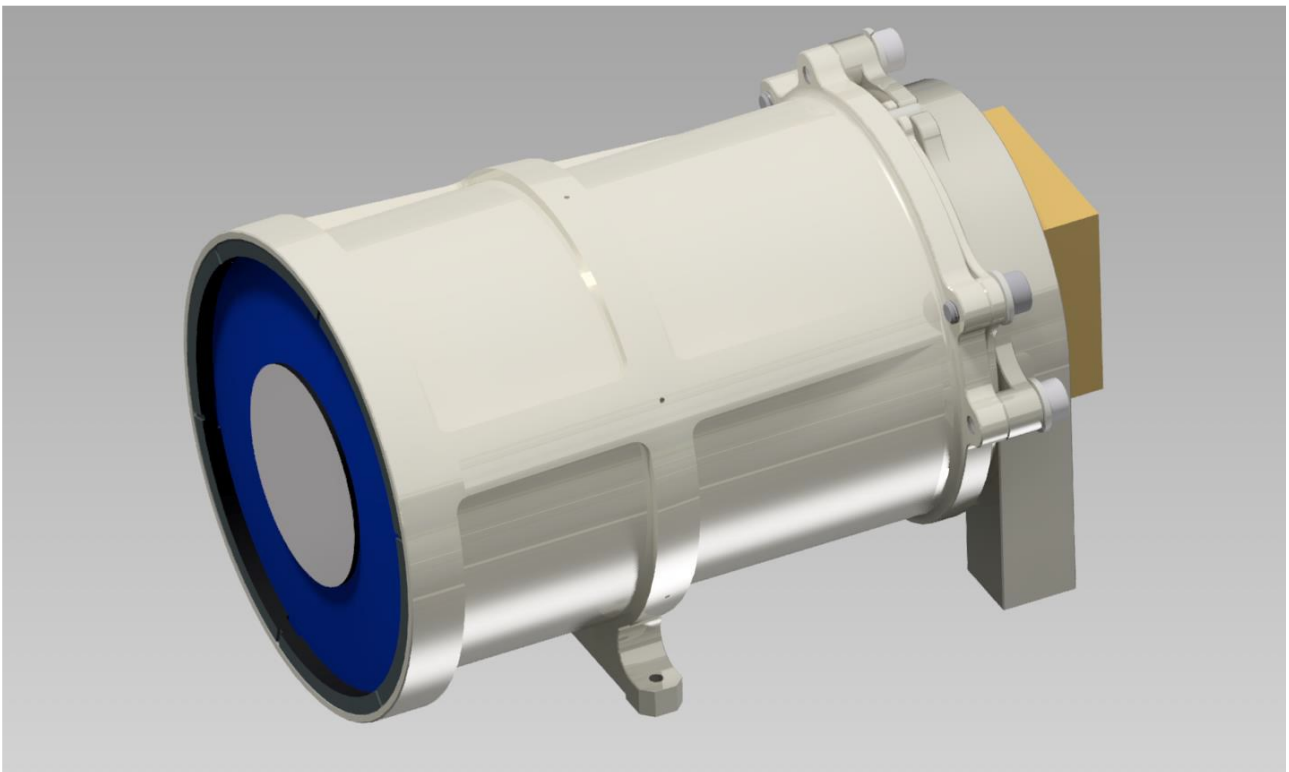

**Figure 1 – CAD rendering of the LEIA Instrument**

LEIA (Fig. 1) is composed by a catadioptric telescopic camera with 2 reflective and 3 refractive elements. The Field of View (FoV) is equal to  $\pm 2.06^\circ$  on the sensor diagonal (i.e.,  $2.9^\circ$  on both the horizontal and vertical axis). The detector is a CMOS sensor (CMV4000) with 2048x2048 pixel. It is

a highly miniaturized, compact (35x35x23mm) and high-performance camera. It integrates a reconfigurable Flash-based FPGA, its frame rate is equal to 7 fps saving in RAM and 0.5 fps saving in the payload mass memory (flash memory) at 12 bit resolution. It is a panchromatic detector, which also integrates clock and timing generators, as well as image signal processor functions, an on-chip temperature sensor, programmable gain amplifier and offset regulators. LEIA is aimed at acquiring pictures from long distance (close approach at ~50 km from Dimorphos), providing high level of details of the frame field.

#### 4.1.1.1 Optical properties

The main optical properties of the cameras are reported into Table 2.

Table 2 - LEIA optical properties

#	Requirement	Description
1	Diagonal FoV	2.9 deg along both horizontal and vertical axis (2048x2048 px – 5.5µm)
2	Focal Length	222.55 mm
3	IFOV (n° pixel)	24.71 µrad (5.5µm pixel)
4	f/ratio	3
6	Wave length	450-900 nm
7	Transmission (obscuration not considered)	More than 87%
8	Maximum Resolution	91 lp/mm
9	Distortion	< 1%
10	Overall Transmission	> 90%

The design is optimized in order to achieve an average residual reflection less than 0.3% in the range 400-900nm. This means an overall transmission of 48% (including obscuration) that is equivalent to 92% if obscuration is not considered.

The optical system is not affected by distortion since it has been evaluated to be less than 1%.

#### 4.1.1.2 Detector Properties

The detector is a panchromatic CMOS sensor (CMV4000) with 2048x2048 pixel. The image array consists of 5.5µm x 5.5µm pipelined global shutter pixels which allow exposure during read-out, while performing CDS operation. The image sensor has sixteen 10- or 12-bit digital LVDS outputs (serial)

In Table 3 the detector characteristics are reported.

Table 3 – Detector characteristics

#	Feature	Description
1	Sensor	CMOS CMV4000
2	Number of pixels	2048 x 2048

#	Feature	Description
3	Pixel size	5.5 $\mu\text{m}$
4	Colour filters	Panchromatic (400-900 nm)
5	Pixel reading resolution	10bit or 12 bit
6	Integration time range	From 0.1ms up to seconds
7	Integration time granularity	0.1 ms

An analog gain and ADC gain can be applied to the output signal. The analog gain is applied by a PGA in every column. The digital gain is applied by the ADC. The two parameters are set to 1x.

The captured images are 2048x2048-pixel raw image, with 12-bits per pixel, has a size 8MB (each pixel is considered saved in 2 byte). The payload acquires pictures in raw format, i.e., raw extracted data without any processing. In order to reduce the picture dimensions two different manipulations are possible: binning (2x2) and windowing. The 2x2 binning manipulation interpolates together group of four pixels reducing the picture dimension by a factor of 4. This aggregation, although associated with loss of information, reduces the amount of data to be processed. All the pictures have a depth of 12-bit, which results in pictures with size of 8 Mbyte.

#### 4.1.2 LUKE

LUKE is a dioptric camera composed by 4 refractive elements, with a diagonal FoV of  $10^\circ$ . The detector is a CMOS sensor (CMV2000) with 2048x1088 pixel. It is interfaced with the NanoCU, the data elaboration unit of the camera, through a flexible PCB, to minimize any mechanical stresses. The pictures acquired by LUKE are in raw format, which represents the raw data extracted by the photo sensor, without any processing. All the pictures have a depth of 8-bit, which yields to have pictures with size of about 2 Mbyte.

##### 4.1.2.1 *Optical properties*

The payload is a dioptric camera composed by 4 refractive elements (see Figure 2). In this paragraph the design of the optic will be presented.



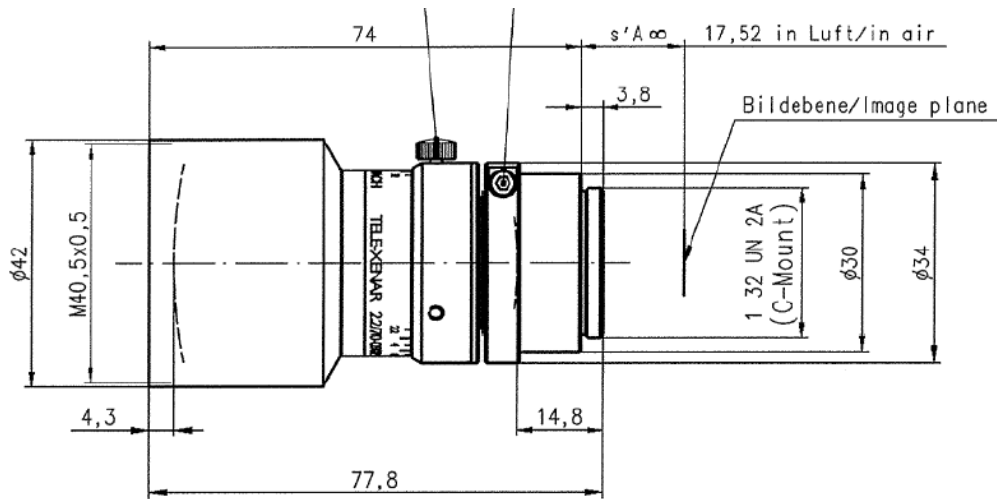

**Figure 2 – Lens design**

The main optical properties of the cameras are reported in Table 4: distortion at every allowed focal distance is always lower than 0.1% in absolute value.

Table 4 - LUKE main optical properties

#	Requirement	Description
1	Diagonal FoV	10 deg (2048x1088 px – 5.5µm)
2	Focal Length	70.5 mm
3	IFOV (n° pixel)	78.01 µrad (5.5µm pixel)
4	f/ratio	2.2
5	Wavelength	450-700 nm
6	Distorsion	< 0.1 %

An AR coating will be included to be compliant with transmission requirements.

#### 4.1.2.2 Detector Properties

The detector is a CMOS sensor (CMV2000) with 2048x1088 pixel. It is interfaced with the NanoCU, the data elaboration unit of the camera, through a flexible PCB, to minimize any mechanical stresses.

The pixel array consists of 2048 x 1088 square global shutter pixels with a pitch of 5.5µm (5.5µm x 5.5µm). This results in an optical area of close to 2/3 optical inch (12.7mm).

The detector acquires a full-size 2048x1088-pixel raw image with 10-bit per pixel, but the payload electronics store a full-size 2048x1088-pixel raw image with 8-bit per pixel saving the first 8-bit per pixel.

To this aim, a dedicated command is used: one of its parameters is “Bottom\_Not\_Top” which configure the related payload register 0x1E (Bit Selection). This feature implements the following behaviour: “Setting bit 0 will use the bottom 8 bits of the sensor’s 10-bit digitized pixel values. Setting bit 1 will prevent clamping of pixels to 255 if they are larger than 255”.

The selection of this option shall be evaluated during the calibration mission's phase, by default, value is 0.

The application of this procedure leads to no uncertainties: data received will have the same data structure choosing the most significant bits or the least one. Image will be reconstructed as well in both cases. Only the histogram will change. Bit shift selection (most/least significant bits) will result in a reduction of the magnitude of the signal value per pixel (most significant bit selected) or in a magnitude reduction (least significant bit). The added 4 bit to reach 16 bit are not used and set to "0".

In order to avoid misunderstanding between planned shoots configuration and effective shoots, the download picture procedure prescribes the download of Images information Table (IAT). The IAT register for each photo, the sensor configuration programmed (even the bit selection).

The raw image dimension is 2Mbyte. Table 5 reports the main detector characteristics.

Table 5 – LUKE characteristics

#	Feature	Description
1	Sensor	CMOS CMV2000
2	Number of pixels	2048 x 1088
3	Pixel size	5.5 $\mu\text{m}$
4	Colour filters	Bayer Filter
5	Pixel reading resolution	10bit
6	Integration time range	From 0.1ms up to seconds
7	Integration time granularity	0.1 ms

An analog gain and ADC gain can be applied to the output signal. The analog gain is applied by a PGA in every column. The digital gain is applied by the ADC. The two parameters are set to 1x.

The RGB is obtained using a Bayer Filter (Fig. 3), i.e., a color filter array (CFA) for arranging RGB color filters on a square grid of photosensors, used in most single-chip digital image sensors for digital cameras.

The raw output of Bayer-filter cameras is referred to as a Bayer pattern image. Since each pixel is filtered to record only one of three colors, the data from each pixel cannot fully specify each of the red, green, and blue values on its own. To obtain a full-color image, various demosaicing algorithms can be used to interpolate a set of complete red, green, and blue values for each pixel. These algorithms make use of the surrounding pixels of the corresponding colors to estimate the values for a particular pixel.

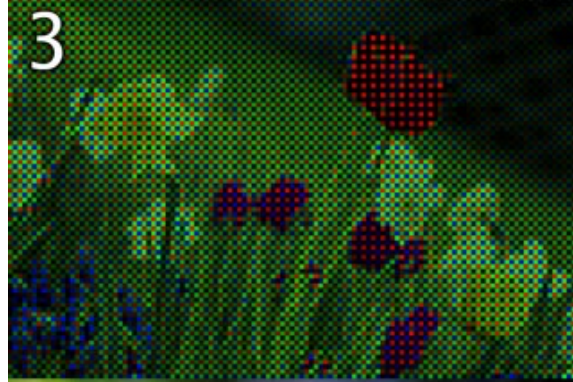

**Figure 3: 1) Original scene; 2) Output of a 120×80-pixel sensor with a Bayer filter; 3) Output color-coded with Bayer filter colors; 4) Reconstructed image after interpolating missing color information; 5) Full RGB version at 120×80-pixels for comparison.**

## 4.2 Data Product Overview

This SIS describes image and engineering data acquired by LEIA and LUKE instruments of LICIACube. Images from these imagers and their associated calibration files use the same binary Flexible Image Transport System (FITS) file format with similar keywords for both raw and calibrated images.

### 4.2.1 LICIACube LEIA Data Product Overview

Images from LEIA will be constituted by a 2048x2048 pixel 2-D array (i.e., NAXIS = 2) at 16-bit for raw data and 32-bit for calibrated data and, since these products will be delivered to PDS labelled according to PDS4 standard, it is important to note that image axis labelling from the FITS standard to the PDS standard is opposite. The FITS standard is first-index-fastest, where NAXIS1 is the most quickly changing subscript, whereas the PDS axis labelling is last-index-fastest notation. This means that:

- NAXIS2 is labelled in the PDS4 array as axis 1 with an <axis name> of “line”;
- NAXIS1 is labelled as axis 2 with an <axis name> of “sample”.

In this document the FITS axis labelling standard is used to refer to all axes in data products.

The specific data products described by this SIS are:

- LEIA raw images (digital numbers)
- LEIA calibrated images (radiance)
- LEIA calibration files (files needed to process raw images data into calibrated images)
- LUKE raw images (digital numbers)
- LUKE calibrated images (radiance)
- LUKE calibration files (files needed to process raw images into calibrated images)

### 4.2.2 LICIACube LUKE Data Product Overview

Raw images from LUKE will be constituted by a 2048x1088 pixel 2-D array (i.e., NAXIS = 2) at 8-bit, whereas calibrated images from LUKE will have 3 channels (i.e., RGB, NAXIS = 3), each of them made of a 2048x1088 pixel 32-bit. Since this product will be delivered to PDS labelled according to PDS4 standard, it is important to note that image axis labelling from the FITS standard to the PDS standard is opposite. The FITS standard is first-index-fastest, where NAXIS1 is the most quickly changing subscript, whereas the PDS axis labelling is last-index-fastest notation. For the calibrated images this results in:

- NAXIS3 is labelled in the PDS4 array as axis 1 with an <axis name> of “band”;
- NAXIS2 is labelled in the PDS4 array as axis 2 with an <axis name> of “line”;

- NAXIS1 is labelled as axis 3 with an <axis name> of “sample”.

In this document the FITS axis labelling standard is used to refer to all axes in data products.

The specific data products described by this SIS are:

- LUKE raw images (digital numbers)
- LUKE calibrated images (radiances)
- LUKE calibration files (files needed to process raw image data into calibrated images)

### 4.3 Data Processing

All LICIACube mission science data processing is performed at the LSOC. LEIA science and housekeeping telemetries are received by the LSOC via the Argotec Mission Control Center (MCC) as soon as they are downlinked through the Deep Space Network (DSN). Telemetry data are reconstructed at the MCC and stored in the LSOC data repository, where they are also converted in FITS format, to be compliant to the PDS4 standard.

Reconstructed Telemetry raw image and housekeeping data are retrieved by the data repository, housekeeping physical unit conversions are applied and stored, and raw image data are fed into the LCC specific data processing pipeline. The pipeline produces raw (Level-0) and calibrated (Level-2) LCC LEIA and LUKE images written as FITS files. Image data are also stored in the SOC database. Production rates of images vary over the course of the mission, as images are acquired to meet specific science goals. Reconstructed Telemetry raw image data are approximately 8 MB for LEIA and 2 MB for LUKE; calibrated images 16 MB for LEIA and 18 MB for LUKE.

#### 4.3.1 Data Processing Level

Table 6 shows the LICIACube data processing levels of all science data products described by this SIS. Correlation to NASA and CODMAC data processing levels and definitions can be found in [AD1].

Table 6. LICIACube LEIA and LUKE Data Processing Levels

LICIACube Data Product	NASA Product Level	PDS4 Data Processing Level	Description
LEIA Raw Images	Level-0	Raw	Images reassembled from downlinked packets
LEIA Calibrated Images	Level-2	Calibrated	Images calibrated to physical units (radiance)
LEIA Calibration Files	Level-4	Calibrated	Files needed to process raw image data
LUKE Raw Images	Level-0	Raw	Images reassembled from downlinked packets

LUKE Calibrated Images	Level-2	Calibrated	Images calibrated to physical units (radiance)
LUKE Calibration Files	Level-4	Calibrated	Files needed to process raw image data

## 4.4 Data Product Generation

As mentioned previously, all LICIACube science data processing is completed at the LSOC located at ASI-SSDC. The decision was made early in the mission lifecycle, that all processing would be centralized to facilitate the relatively quick turnaround needed by the science and operations teams to identify and assess the DART impact site and ejecta.

### 4.4.1 LICIACube LEIA Level-0 Raw Images

LCC LEIA images and housekeeping telemetries are received by the MCC from the DSN. The MCC reconstructs images from the raw telemetry, sending the resulting 16-bit image to the LSOC, which populates a suite of FITS keywords, which includes information on LEIA mode, and records of any windowing, binning, and calibration done via the on-board image processing pipeline, together with the TARGET and MPHASE (mission phase) keywords. The LSOC also stores the image in the FITS file in 16-bit integer format. The resultant FITS header is defined in Section 5.2.1 and compliant to what is described in [AD2]. Keyword values are directly derived from LCC telemetry (including the LCC header row), the GNC correlation packet, and some other spacecraft telemetry packets to which the MCC has direct access.

Each final Level-0 raw PDS4 data product will consist of:

- A 16-bit FITS file with one Header Data Unit (HDU) containing the metadata header fields and the data unit of the array (2048 pixels x 2048 pixels for not windowed nor binned images). Windowed or binned images have less pixels than this original format: information about the windowed image position and dimension can be retrieved by means of the WINXSTA, WINXEND, WINYSTA, WINYEND FITS keywords. The data are represented as DN.
- A browse PNG created from the raw FITS file, with its same dimension in pixel.

### 4.4.2 LICIACube LEIA Level-2 Calibrated Images

LCC LEIA calibrated images have gone all the way through the calibration pipeline at the SOC, as described in Section 4.4.2.1: the calibration process is more accurately described in the LICIACube Calibration Document [AD3]. The calibration pipeline appends additional keywords to the FITS header keywords of the raw images (defined in Section 5.2.2). Some raw images, pertaining to the approach mission phase, will not be turned into calibrated images (e.g., not full frame images). Additional data needed to interpret the calibrated images, such as, for example, bias frames, dark current frames, and flat field, are part of the LCC Calibrated Dataset.

Each final Level-2 calibrated PDS4 data product will consist of:

- A 32-bit FITS file with a single HDU containing header metadata records and a data unit of the radiometrically calibrated windowed array (2048 pixels x 2048 pixels for not windowed nor binned images). Windowed or binned images have less pixels than this original format: information about the windowed image position and dimension can be retrieved by means of the WINXSTA, WINXEND, WINYSTA, WINYEND FITS keywords. The data are represented in spectral radiance ( $W m^{-2} nm^{-1} sr^{-1}$ ). Additional FITS keywords are added by the SOC to capture metadata relevant to the calibrated image, such as calibration files used.
- A browse PNG created from the raw FITS file, with its same dimension in pixel.

#### 4.4.2.1 LICIACube LEIA Calibration Files

The following calibration files have been developed from in-flight and/or ground calibration data: Calibration FITS cubes (2 for LEIA and 2 for LUKE). Calibration files have been saved in FITS file format.

A detailed description of the calibration files follows, whereas the description of the pipeline can be found in [AD3].

The two calibration files for LEIA are:

- `liciacube_leia_cal_col_001.fits`: containing the parameters for the radiometric calibration function
- `liciacube_leia_cal_gen_001.fits`: containing values for the parameters to be applied before the radiometric calibration

The `liciacube_leia_cal_gen_001.fits` file is a 4 x 2048 x 2048:

- Plane 1: Bias for corresponding (i,j) pixel in DN
- Plane 2: Bad pixel map
- Plane 3: Dark current plane 1
- Plane 4: Dark current plane 2

The `liciacube_leia_cal_col_001.fits` file has a single plane, containing an array of lists of size [3, 4194304, 13] (4194304 is the number of pixels in the LEIA raw image, i.e., 2048 x 2048), defining the parameters for the spline interpolation, according to the `PchipInterpolator` `scipy` Python function. The effective number of parameters in every list can vary from pixel to pixel up to 13 according to what needed by the function used in the (i,j) pixel: the non-needed parameters are stored with the not applicable constant `1e32`.

The calibration pipeline can be represented by the workflow in Fig. 4:

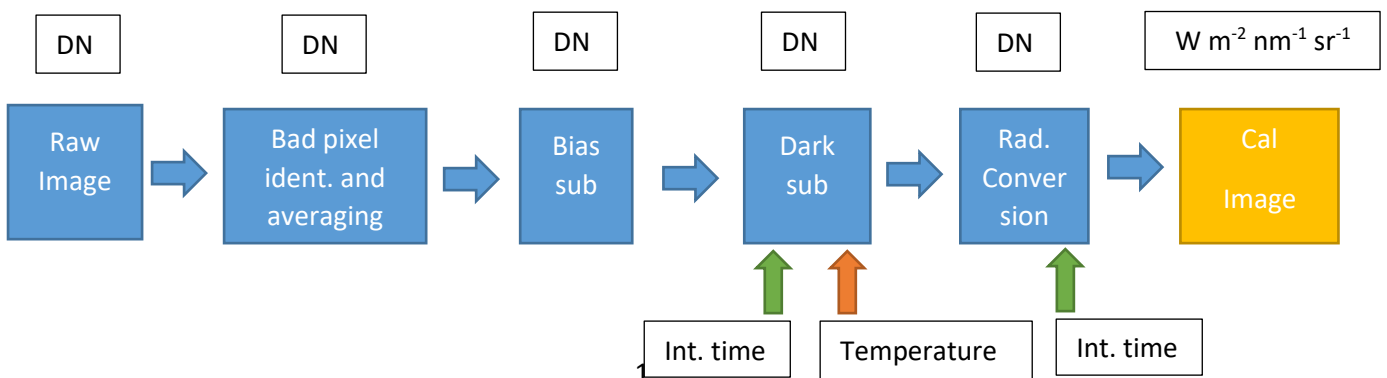

#### Figure 4: LEIA flow from raw to calibrated images

##### 4.4.2.2 LICIACube LUKE Level-0 Raw Images

LCC LUKE image and housekeeping telemetry are received by the MCC from the DSN. The MCC reconstructs 8-bit images from the raw telemetry by performing the cut of the signal to the 8 chosen bit per pixel per channel (i.e., most or least significant ones), in order to select the best part of the acquired histogram for LUKE. Then it sends the resulting image to the LSOC, which populates a suite of FITS keywords, which includes information on LUKE mode, spacecraft attitude, and records of any windowing, binning, and calibration done via the on-board image processing pipeline, together with the TARGET and MPHASE (mission phase) keywords. The LSOC also stores the image in the FITS file in 8-bit integer format. The resultant FITS header is defined in Section **Errore. L'origine riferimento non è stata trovata.**5.2.5 and compliant to what described in [AD2]. Keyword values are directly derived from LCC telemetry (including the LCC header row), the GNC correlation packet, and some other spacecraft telemetry packets to which the MCC has direct access.

Each final Level-0 raw PDS4 data product will consist of:

- A 8-bit FITS file with one Header Data Unit (HDU) containing the metadata header fields and the data unit of the windowed array (2048 pixels x 1088 pixels for not windowed nor binned images). Windowed or binned images have less pixels than this original format. The data are represented as DN.
- A browse PNG created from the raw FITS file, with its same dimension in pixel.

##### 4.4.2.3 LICIACube LUKE Level-2 Calibrated Images

LCC LUKE calibrated images have gone all way through the calibration pipeline at the SOC, as described in 4.3.2.6: the calibration process is more accurately described in the LICIACube Calibration Document [AD3]. The calibration pipeline appends keywords to the FITS header keywords of the raw images (defined in Section 5.2.6). Some raw images, pertaining to the approach mission phase, will not be turned into calibrated images (e.g., not full frame images). Additional data needed to interpret the calibrated images, such as bias frames, dark current frames, and flat field, are included in the as part of the LUKE Calibrated Data.

Each final Level-2 calibrated PDS4 data product will consist of:

- A 32-bit FITS file with a single HDU containing header metadata records and a data unit of the radiometrically calibrated windowed array (3 x 2048 pixels x 1088 pixels for not windowed nor binned images). Windowed or binned images have less pixels than this original format, but the same number of bands. The data are represented in radiance ( $W m^{-2} nm^{-1} sr^{-1}$ ). Additional FITS keywords are added by the SOC to capture metadata relevant to the calibrated image, such as calibration files used.
- A browse PNG created from the raw FITS file, with its same dimension in pixel.

##### 4.4.2.4 LICIACube LUKE Calibration Files



The following calibration files will be developed from in-flight and/or ground calibration data: Calibration FITS cubes (2 for LEIA and 2 for LUKE). Calibration files will be saved in FITS file format.

A detailed description of the calibration files follows, whereas the description of the pipeline can be found in [AD3].

The two calibration files for LUKE are:

- `liciacube_luke_cal_col_001.fits`: containing the parameters for the radiometric calibration function
- `liciacube_luke_cal_gen_001.fits`: containing values for the parameters to be applied before the radiometric calibration

The `liciacube_luke_cal_gen_001.fits` file is an 7 x 2048 x 1088 array:

- Plane 1: bias for corresponding (i,j) pixel in DN
- Plane 2: Bad pixel map
- Plane 3: Dark current plane 1
- Plane 4: Dark current plane 2
- Plane 5: Flat matrix for red channel
- Plane 6: Flat matrix for green channel
- Plane 7: Flat matrix for blue channel

The `liciacube_luke_cal_col_001.fits` file has a single plane, containing an array of lists of size [3, 3, 2228224, 11] (2228224 is the number of pixels in the LUKE raw image, i.e., 2048 x 1088), defining the parameters for the spline interpolation, according to the `PchipInterpolator` `scipy` Python function. The effective number of parameters in every list can vary from pixel to pixel up to 11 according to what needed by the function used in the (i,j) pixel: the non-needed parameters are stored with the not applicable constant value of  $1e32$ .

The calibration pipeline can be represented by the workflow in Fig. 5:

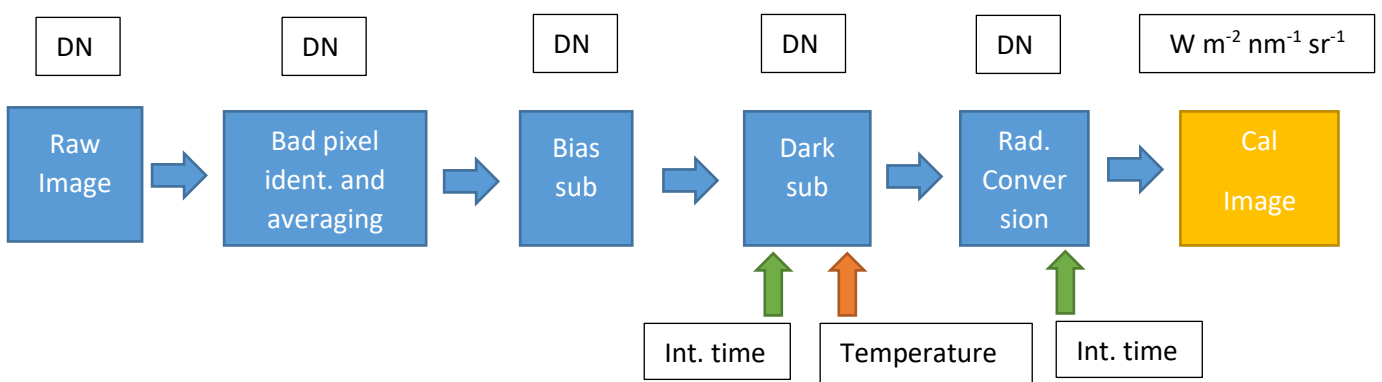

Figure 5: LUKE flow from raw to calibrated images

The obtained images for LUKE shall be de-bayerized (just before the radiance conversion step) to obtain the 3 planes of the FITS by a standard algorithm used for the RGB scheme of LUKE detector.

The filter used is a CFA ‘RGGB’ one, following the algorithm described in Menon et al. (2007).

### 4.4.3 Data Flow

The MCC reconstructs LCC LEIA/LUKE images from the raw telemetry. LSOC populates a suite of FITS keywords (see also Sections 4.3.2.1, 4.2.3.2, 4.2.3.4 and 4.3.2.5). Calibrated images are created by the LICIACube Calibration Pipeline (see also Sections 4.3.2.3 and 4.3.2.6). If data reprocessing leads to more than one version of a raw, calibrated, or derived data product (due to, e.g., updated SCLK information, updated calibration files, shape models), re-processed images can be identified by the two-digit version number in the file name (see Section 4.3.4; Table 7). Raw, calibrated, and derived data products are stored at the LSOC. These products, with the calibration files and associated documentation, are combined to form the LEIA and LUKE collections within the LICIACube Spacecraft Bundle, which is delivered to the Small Bodies Node (SBN) of the PDS. The full list of collections described in this SIS is:

- LEIA Raw Data Collection
- LEIA Calibrated Data Collection
- LUKE Raw Data Collection
- LUKE Calibrated Data Collection
- Documentation collection specifically for the LICIACube documentation.

This archive provides one public access point to the LICIACube data. The raw, calibrated, and derived data products are also available in the Small Body Mapping Tool (SBMT; <https://sbmt.jhuapl.edu>), which includes image search, 3D visualization, and download capabilities.

Some of the LICIACube data are also available from the SSDC MATISSE tool (<https://tools.ssdsc.asi.it/Matisse>) with advanced search and visualization capabilities directly from the web.

### 4.4.4 Labeling and Identification

All LEIA and LUKE data products are labelled with PDS4 compliant detached XML labels. These labels describe the content and format of the associated data product. Labels and products are associated by file name with the label having the same name as the data product but with the .xml extension.

Additional information regarding the XML labels and PDS4 data product specification can be found in the PDS documents referenced in Section 2.

LEIA and LUKE uncalibrated and calibrated data products are identified with file names in the format of:

liciacube\_\*\*\*\*\_IK\_SSSSSSSSSS\_####\_##.<extension>

Table 7. Definition of LICIACube filename

File section	name	Description
****		payload source (leia, luke)

K	level of processing (0=Raw image, 2=calibrated, 4=derived)
SSSSSSSSSS	10-digit value of SCLK (seconds, raw 32-bit value)
sssss	5-digit value of SCLK (sub-seconds, raw 16-bit value)
##	two digit version number, e.g., “01”
<extension>	the file extension. “.fits” for FITS file format, “.png” for PNG files, “.xml” for XML labels

The naming convention for the LICIACube calibration files is shown in Table 8.

Table 8. File formats and naming conventions of calibration inputs

Pipeline input	File format	File naming scheme	Quantity expected per delivery
<b>LEIA Calibration “cube” file</b>	4x2048x2048 64-bit floating point FITS	liciacube_leia_cal_gen_001.fits	1
<b>LEIA radiometric calibration file</b>	[3, 4194304, 13] 64-bit floating point FITS	liciacube_leia_cal_col_001.fits	1
<b>LUKE Calibration “cube” file</b>	7x2048x1088 64-bit floating point FITS	liciacube_luke_cal_gen_001.fits	1
<b>LUKE radiometric calibration file</b>	[3, 3, 2228224, 11] 32-bit floating point FITS	liciacube_luke_cal_col_001.fits	1

## 4.5 Standards Used in Generating Data Products

### 4.5.1 PDS Standards

All data products described in this SIS conform to PDS4 standards as described in [AD2]. Prior to public release, all data products will have passed both a data product format PDS peer review and a data product production pipeline PDS peer review to ensure compliance with applicable standards.

## **4.5.2 Time Standards**

Time Standards used by the LICIACube mission conform to PDS time standards. All LICIACube data products contain the spacecraft clock time at the start of the data acquisition to facilitate comparison of data products.

## **4.5.3 Coordinate Systems**

All coordinate systems used by the LICIACube mission conform to IAU standards. A complete discussion of the coordinate systems and how they are deployed in the mission can be found in the document “DART Coordinate System Plan” found in the archive documents directory.

## **4.5.4 Data Storage Conventions**

FITS data products are stored according to the FITS 3.0 Standard. Binary data products are stored as big-endian (MSB) binary.

## **4.5.5 Data Validation**

The LSOC has a comprehensive Verification and Validation Plan for all software used at or developed by the LSOC. All software is configuration controlled and any changes made follow the LSOC Configuration Control Plan, which includes substantive testing of changes. During the day-to-day production of Level-0 data products from telemetry, check sums and spot checks are used to validate that software is producing data products correctly.

In addition to software verification and validation, each LICIACube LEIA and LUKE data product has been peer reviewed for both PDS data format acceptability and scientific usefulness. No changes are expected to data formats after peer review. The LSOC Configuration Control Plan governs any changes, should they be needed.

When data is prepared for submission to the PDS, the Teams will use PDS / mission-provided validation tools for conformance to the PDS4-standards.

# **5 Detailed Data Product Specification**

## **5.1 Data Product Structure and Organization**

The LICIACube data archive, for what regards image data, is organized by: instrument (LEIA/LUKE), level (raw/calibrated), mission phase. All image data is stored as FITS files with a detached PDS label. The detached PDS labels are PDS4 compliant XML labels that describe the contents of the image file and record the significant portions of the FITS header for data processing and interpretation.

LICIACube operated in the following DART mission phases:

1. Approach phase. The approach phase began ~30 days prior to the impact of the DART spacecraft. LICIACube has been deployed 15 days prior to DART impact.
2. Final phase. The Final phase started at ~4 minutes prior to the impact of the DART spacecraft and continues through post-impact until the last images are taken by LICIACube.
3. Calibration files are stored in the “Calibration” directory put inside the calibrated directory of the specific instrument (i.e., as “calibration” can be seen as a mission phase)

The LICIACube bundle directory structure is as follows:

- LICIACube
  - leia\_raw
    - approach
    - final
  - leia\_calibrated
    - approach
    - final
    - calibration
  - luke\_raw
    - approach
    - final
  - luke\_calibrated
    - approach
    - final
    - calibration
  - document

## 5.2 Data Format Descriptions

All LICIACube image data are stored natively in FITS file formats and delivered to the PDS in PDS4 compliant arrays.

LEIA images will be stored as PDS4 compliant 2D arrays. Reconstructed Telemetry (raw) image (Level-0) FITS headers and PDS Labels contain raw (DN) telemetry values. Calibrated (Level-2) FITS headers and PDS labels have DN values that are converted to physical units, e.g. radiance.

LUKE images will be stored as PDS4 compliant 2D arrays (raw) and 3D arrays (calibrated). Reconstructed Telemetry (raw) image (Level-0) FITS headers and PDS Labels contain raw (DN) telemetry values. Calibrated (Level-2) FITS headers and PDS labels have DN values that are converted to physical units, e.g. radiance.

The Application ID (APID) in the FITS file is the unique identifier for the original packets in the instrument telemetry. This is used by the SOC pipeline to reconstruct the image and is recorded in the FITS header as part of the image creation process.

### 5.2.1 LICIACube LEIA Raw Image Data

The Level-0 (raw) image format is single HDU FITS files containing a 2048 (line) x 2048 (sample) active image array in 16-bit DN units. Windowed or binned images have less pixels than this original format.

Metadata contained in the FITS header and its mapping to class and attribute in the PDS4 .xml label structure is listed in Table 9. Metadata descriptions may be abbreviated in the FITS header, with full descriptions in the following table.

The Class.Attribute Name column is left blank for FITS keywords not mapped to the .xml label.

Table 9. LEIA Level-0 image metadata

Class.Attribute Name	Keyword and example	Description	Range of values
	SIMPLE = T / file conforms to FITS standard	Required in FITS standard	T
Element_Array. data_type	BITPIX = 16 / number of bits per data pixel	LEIA raw images delivered to the SOC will always be 16 bit. Calibrated images are the result of applying the calibration files, themselves in 32-bit floating point, to the raw images. All are stored in big-endian as per the FITS standard.	16
	NAXIS = 2 / number of data axes	Number of data axes. All LEIA images have 2 axes	2
Axis_Array. sequence_number	NAXIS1 = 2048 / length of data axis 1	Number of rows.	1 to 2048
Axis_Array. sequence_number	NAXIS2 = 2048 / length of data axis 2	Number of columns.	1 to 2048
dart:window_x_start	WINXSTA = '-1' / X origin of window	Column where window starts. Window coordinates are with respect to a 2048 x 2048 image. The upper left hand corner of the image plus header row is coordinate 0,0. -1 if second windowing not applied.	-1 to 2047
dart:window_y_start	WINYSTA = '-1' / Y origin of window	Row where window starts. Window coordinates are with respect to a 2048 x 2048 image. The upper left hand corner of the image plus header row is coordinate 0,0. -1 if second windowing not applied.	-1 to 2047
dart:window_x_end	WINXEND= '2048' / X end of window	Column where window ends. Window coordinates are with respect to a 2048 x 2048 image. The upper left hand corner of the image plus header row is coordinate 0,0. -1 if second windowing not applied.	2 to 2048
dart:window_y_end	WINYEND= '2048' / Y end of window	Row where window ends. Window coordinates are with respect to a 2048 x 2048 image. The upper left hand corner of the image plus header row is coordinate 0,0. -1 if second windowing not applied.	2 to 2048

	EXTEND = T / FITS dataset may contain extensions	By default, set to T so that we can add extensions if needed.	T
Modification_History. modification_date	DATE = '2018-08-25T09:23:89' / FITS header creation date YYYY-MM-DDTHH:MM:SS	Time FITS file was created by the SOC. For calibrated and derived it is the creation time of the product	YYYY-MM-DDTHH:MM:SS
Investigation_Area. name	MISSION = 'DART / Mission: DART	Name of mission	DART
Observing_System. name	HOSTNAME = 'LICIACube' / spacecraft name	LEIA is on the spacecraft named LICIACube	LICIACube
Observing_System_Component. name	INSTRUME = 'LEIA' / Instrument name	Instrument name	LEIA
	APID	Application ID of science image data: the images themselves	TBR
	TARGET = 'DIMORPHOS' / Target Object	Primary target object	"DIMORPHOS"
dart:mission_phase	MPHASE = 'approach' / phase of the mission	The DART mission is divided into phases; this keyword states the phase during which the image was acquired.	"approach", "final"
dart:liciacube_sclk_image_time	IMG_TIME = '298271898.013220' / [sec] image TOV	Start of image capture time in spacecraft clock notation. Numeric number preceding the decimal point is integer seconds. Numeric number after the decimal point is subsecond clock ticks, where each tick represents 1/256 of second.	Time since t=0, as defined in the SCLK kernel.  Left blank when not available.
	IMG_UTC = '2022 OCT 01 10:28:09.600' / Image TOV in UTC	Start of image capture time in UTC.	
	SCLKNAME = 'liciacube_sclk_0000.tsc' / SCLK file used for IMG_UTC	Name of SCLK file used to compute IMG_UTC	
dart:readout_time	READOUT = '165300' / Readout time in microsec	Global readout time in microseconds.	From 165300 microsec to 165700 microsec
img:exposure_duration	EXPTIME = '0.156789' / [sec] Exposure time	Image exposure time in seconds	0.00002882s to 338.16s.
dart:gain	GAIN= 1 /Gain setting	Detector gain setting	1., 2., 10., or 30. Float
dart:binning	BINNING = 'ON' / Binning status	If binning is on or not.	'ON' or 'OFF'
	TRUNC= 'MSB' / Truncation mode	Defines whether the data are truncated using MSB or LSB. When binning is enabled, the truncation mode is MSB. When binning is disabled, the truncation mode is LSB.	"MSB" or "LSB".
	RCNTTHST = 1 / thruster firing flag	Flag whether thrusters were fired within one settling time before this image. =1 true, =0 false (TBR)	0 or 1. Integer
	AOCWX = 0 / [deg/s] rotation speed on X axis	Rotation speed of LICIACube frame X axis	

	AOCWY = 0 / [deg/s] rotation speed on Y axis	Rotation speed of LICIA Cube frame Y axis	
	AOCWZ = 0 / [deg/s] rotation speed on Z axis	Rotation speed of LICIA Cube frame Z axis	
dart:detector_temp	DETTEMP = 18.333 / [degC] Detector temperature	LEIA detector temperature	
	EPHMETA = 'LCC210701-EMK-RN-L211124-V001.mk' / Ephemeris metakernel to be used	Ephemeris metakernel to be used	
	ATTMETA = 'LCC201228-AMK-RN-L221124-V001.mk' / Attitude metakernel to be used	Attitude metakernel to be used	
	SOCQUATA = '0.10808003767484.' /SC quaternion in J2000 (q0) using A CORT UTC	Spacecraft quaternion computed by the SOC using SPICE and CORT UTC	
dart.correct_image_time	CORT.UTC	UTC time at mid-exposure time used to define attitude and representative observing geometry.	Time at mid exposure used to define attitude and representative geometric attributes. Since the acquisition operation is verified to be successful after a 250 ms delay, from the effective time of acquisition (defined as tCUC), this value is computed as: CORT.UTC = tCUC - 0.250s + EXPTIME/2
	CORTJDAT	Julian Ephemeris Date based at mid exposure (= IMGTIME+0.5EXPTIME) used to define attitude and representative observing geometry.	Time at mid exposure used to define attitude and representative geometric attributes. Since the acquisition operation is verified to be successful after a 250 ms delay, from the effective time of acquisition (defined as tCUC), this value is computed converting in Julian Ephemeris Date the following value (computed in UTC): CORT.UTC = tCUC - 0.250s + EXPTIME/2
	SOCQUATX = '- 0.674302095900066' /SC quaternion in J2000 (q1) using CORT.UTC		
	SOCQUATY = '- 0.32453616895850' /SC quaternion in J2000 (q2) using CORT.UTC		
	SOCQUATZ = '0.65445524213556' /SC quaternion in J2000 (q3) using appropriate CORT.UTC time		



	BORE_RA = '326.459994' / [deg] Boresight right ascension	Boresight right ascension	0 to 360 degrees.
	BORE_DEC = '-38.093559' / [deg] Boresight declination	Boresight declination	-90 to 90 degrees
	CELN_CLK = '28.16' / [deg] Celestial north clock angle	Celestial north clock angle	0 to 360 degrees.
	ECLN_CLK = '49.30' / [deg] Ecliptic north clock angle	Ecliptic north clock angle	0 to 360 degrees.
	SUN_CLK = '318.40' / [deg] Sun clock angle	Sunward direction clock angle	0 to 360 degrees.
	PXARCS = '1.02' / [arcsec] Pixel scale	Pixel scale in arcsec	Either 1.02 arcsec if BINNING = ON or 0.512 arcsec if BINNING = OFF.
	PXMRAD = '4.96' / [microradians] Pixel scale	Instantaneous field of view of a pixel, in microradians. If BINNING = ON, this value is reported for a 2x2 binned pixel.	Either 4.96 urad if BINNING = ON or 2.48 urad if BINNING = OFF.
	PHDIST = '1.04' / [AU] Heliocentric distance - Primary	Distance between the sun and the primary target, in AU	Calculated for selected TARGET values only (e.g., Didymos, Dimorphos, etc.), otherwise set to -1E32.
	PSCRNG = '4.2622E+02' / [km] Spacecraft range - Primary	Distance between the spacecraft and the primary target center, in km	Calculated for selected TARGET values only (e.g., Didymos, Dimorphos, etc.), otherwise set to -1E32.
	PSPHASE = '55.98' / [deg] Solar phase angle - Primary	Angle between the sunward direction and the direction to the spacecraft, as observed from the primary target.	0 to 180 degrees. Calculated for selected TARGET values only (e.g., Didymos, Dimorphos, etc.), otherwise set to -1E32.
	PSELON = '73.49' / [deg] Solar elongation - Primary	Angle between the sunward direction and the direction to the primary target, as observed from the spacecraft.	0 to 180 degrees. Calculated for selected TARGET values only (e.g., Didymos, Dimorphos, etc.), otherwise set to -1E32.
	PPPCLK = '228.64' / [deg] Positive pole clock angle - Primary	Positive pole clock angle of the primary target	0 to 360 degrees. Calculated for selected TARGET values only (e.g., Didymos, Dimorphos, etc.), otherwise set to -1E32.
	PSUBLAT = '38.04' / [deg] Sub-observer latitude - Primary	Sub-observer latitude of the primary target	-90 to 90 degrees. Calculated for selected TARGET values only (e.g., Didymos,

			Dimorphos, etc.), otherwise set to -1E32.
	PSSUBBLON = '146.65' / [deg] Sub-observer longitude - Primary	Sub-observer east longitude of the primary target	0 to 360 degrees. Calculated for selected TARGET values only (e.g., Didymos, Dimorphos, etc.), otherwise set to -1E32.
	PSSOLLAT = '-1.07' / [deg] Sub-solar latitude - Primary	Sub-solar latitude of the primary target	-90 to 90 degrees. Calculated for selected TARGET values only (e.g., Didymos, Dimorphos, etc.), otherwise set to -1E32.
	PSSOLLON = '190.18' / [deg] Sub-solar longitude - Primary	Sub-solar east longitude of the primary target	0 to 360 degrees. Calculated for selected TARGET values only (e.g., Didymos, Dimorphos, etc.), otherwise set to -1E32.
	SHDIST = '1.04' / [AU] Heliocentric distance - Secondary	Distance between the sun and the secondary target, in AU	Calculated for selected SECTAR values only (e.g., Didymos, Dimorphos, etc.), otherwise set to -1E32.
	SSCRNG = '4.2623E+02' / [km] Spacecraft range - Secondary	Distance between the spacecraft and the secondary target center, in km	Calculated for selected SECTAR values only (e.g., Didymos, Dimorphos, etc.), otherwise set to -1E32.
	SSPHASE = '56.14' / [deg] Solar phase angle - Secondary	Angle between the sunward direction and the direction to the spacecraft as seen from the secondary target	0 to 180 degrees. Calculated for selected SECTAR values only (e.g., Didymos, Dimorphos, etc.), otherwise set to -1E32.
	SSELON = '73.59' / [deg] Solar elongation - Secondary	Angle between the sunward direction and the direction to the secondary target, as observed from the spacecraft.	0 to 180 degrees. Calculated for selected SECTAR values only (e.g., Didymos, Dimorphos, etc.), otherwise set to -1E32.
	SPPCLK = '228.64' / [deg] Positive pole clock angle - Secondary	Positive pole clock angle of the secondary target	0 to 360 degrees. Calculated for selected SECTAR values only (e.g., Didymos, Dimorphos, etc.), otherwise set to -1E32.
	SSUBLAT = '38.09' / [deg] Sub-observer latitude - Secondary	Sub-observer latitude of the secondary target	-90 to 90 degrees. Calculated for selected SECTAR values only (e.g., Didymos, Dimorphos, etc.), otherwise set to -1E32.
	SSUBLON = '146.46' / [deg] Sub-observer longitude - Secondary	Sub-observer east longitude of the secondary target	0 to 360 degrees. Calculated for selected SECTAR values only (e.g., Didymos,

			Dimorphos, etc.), otherwise set to -1E32.
	SSSOLLAT = '-1.07' / [deg] Sub-solar latitude - Secondary	Sub-solar latitude of the secondary target	-90 to 90 degrees. Calculated for selected SECTAR values only (e.g., Didymos, Dimorphos, etc.), otherwise set to -1E32.
	SSSOLON = '190.18' / [deg] Sub-solar longitude - Secondary	Sub-solar east longitude of the secondary target	0 to 360 degrees. Calculated for selected SECTAR values only (e.g., Didymos, Dimorphos, etc.), otherwise set to -1E32.

## 5.2.2 LICIAcube LEIA Calibrated Image Data

The Level-2 (calibrated) image format is a single HDU FITS file containing a 2048 (line) x 2048 (sample) active image array in 32-bit floating point radiance units. Windowed or binned images have less pixels than this original format.

Metadata contained in the Level-2 LEIA images FITS header and its mapping to class and attribute in the PDS4 .xml label structure is listed in Table 10, where different or absent in Table 9 referring to Level-0 LEIA images. Metadata descriptions may be abbreviated in the FITS header, with full descriptions in the following table.

The Class.Attribute Name column is left blank for FITS keywords not mapped to the .xml label.

Table 10. LEIA Level-2 additional image metadata

Class.Attribute Name	Keyword and example	Description	Range of values
Element_Array. data_type	BITPIX = 32 / number of bits per data pixel	LEIA raw images delivered to the SOC will always be 16 bit. Calibrated images are the result of applying the calibration files, themselves in 32-bit floating point, to the raw images. All are stored in big-endian as per the FITS standard.	32
	RADCONV = 1.0 / Radiance conversion factor	Radiance conversion factor	
	CALFILE='liciacube_leia_cal_001.fits' / ref calibration file	Name of calibration file used.	Determined by file naming convention.
	BADMASKV = '-1E30' / Value assigned to bad pixels	Pixel value assigned to bad	-1E30

		pixels by the SOC	
Special_Constants. missing_constant	MISPXVAL = '1E32' / Value assigned to missing pixels	Keyword created by MOC; value updated by pipeline	1E32
Special_Constants. high_instrument_saturation	SATPXVAL = '1E30' / Value assigned to saturated pixels	Pixel value assigned to saturated pixels by the SOC	1E30

### 5.2.3 LICIACube LEIA Raw Pixel Values

Non-valid pixels (e.g., downlink problems, missing data, dead pixels, etc.) may be present in small numbers within the calibrated image arrays:

- Bad pixels will be associated with the value -1E30
- Missing pixels (e.g. due to downlink problems) will be associated to the value 1E32
- Saturated pixels will be associated to 1E30

### 5.2.4 LICIACube LEIA Calibration File Formats

LICIACube LEIA has two calibration files:

- one with 2048 samples, 2048 lines and 4 bands, containing: bad pixel map, bias, dark, as described in Table 11;
- one with a [3, 4194304, 13] array containing the spline interpolation parameters, as described in Table 12 (4194304 is the number of pixels in the LEIA raw image, i.e., 2048 x 2048).

Table 11. liciacube\_leia\_cal\_gen\_001.fits image metadata

Class.Attribute Name	Keyword and example	Description	Range of values
	SIMPLE = T / file conforms to FITS standard	Required in FITS standard	T
Element_Array. data_type	BITPIX = 64 / number of bits per data pixel	LEIA calibration files have 64 bit per pixel	64
	NAXIS = 3 / number of data axes	Number of data axes.	3
Axis_Array. sequence_number	NAXIS1 = 2048 / length of data axis 1	Number of rows.	2048
Axis_Array. sequence_number	NAXIS2 = 2048 / length of data axis 2	Number of rows.	2048
Axis_Array. sequence_number	NAXIS3 = 4 / length of data axis 3	Number of bands.	4
	CALFILE='liciacube_leia_cal_gen_001.fits' / ref calibration file	Name of calibration file used.	Determined by file naming convention.
	PLANE1 = 'BIAS' / Bias Plane	Bias plane	'BIAS'

	PLANE2 = 'BAD PIXEL MAP' / Bad pixel map plane.	Bad pixel map plane, =0 good pixel, =1 bad pixel	'BAD PIXEL MAP'
	PLANE3 = 'DARK1' / Dark current plane 1	Dark current plane 1	'DARK1'
	PLANE4 = 'DARK2' / Dark current plane 2	Dark current plane 2	'DARK2'
	BADMASKV = '-1E30' / Value assigned to bad pixels	Pixel value assigned to bad pixels by the SOC	-1E30

Table 12. liciacube\_leia\_cal\_col\_001.fits image metadata

Class.Attribute Name	Keyword and example	Description	Range of values
	SIMPLE = T / file conforms to FITS standard	Required in FITS standard	T
Element_Array. data_type	BITPIX = 32 / number of bits per data pixel	LEIA calibration files have 32 bit per pixel	53
	NAXIS = 3 / number of data axes	Number of data axes.	3
Axis_Array. sequence_number	NAXIS1 = 13 / length of data axis 1	Maximum number of parameters.	13
Axis_Array. sequence_number	NAXIS2 = 4194304 / length of data axis 2	Number of pixels.	4194304
Axis_Array. sequence_number	NAXIS3 = 3 / length of data axis 3	Number of parameter lists.	3
	CALFILE='liciacube_leia_cal_col_001.fits' / ref bias file	Name of calibration file used.	Determined by file naming convention.

## 5.2.5 LICIAcube LUKE Raw Image Data

The LUKE Level-0 (raw) image format is a single HDU FITS file containing a 1088 (samples) x 2048 (lines) active image array in 8-bit DN units. Windowed or binned images have less pixels than this original format.

Metadata contained in the FITS header and its mapping to class and attribute in the PDS4 .xml label structure is listed in Table 13. Metadata descriptions may be abbreviated in the FITS header, with full descriptions in the following table.

The Class.Attribute Name column is left blank for FITS keywords not mapped to the .xml label.

Table 13. LUKE Level-0 image metadata

Class.Attribute Name	Keyword and example	Description	Range of values
	SIMPLE = T / file conforms to FITS standard	Required in FITS standard	T
Element_Array. data_type	BITPIX = 8 / number of bits per data pixel	LUKE raw images delivered to the SOC will always be 8 bit. Calibrated images are the result of applying the calibration files, themselves in 32-bit floating point, to the raw images. All are stored in	8

		big-endian as per the FITS standard.	
	NAXIS = 2 / number of data axes	Number of data axes. All LUKE raw images have 2 axes	2
Axis_Array.sequence_number	NAXIS1 = 2048 / length of data axis 1	Number of rows.	1 to 2048
Axis_Array.sequence number	NAXIS2 = 1088 / length of data axis 2	Number of columns.	1 to 1088
	EXTEND = T / FITS dataset may contain extensions	By default, set to T so that we can add extensions if needed.	T
Modification_History.modification_date	DATE = '2018-08-25T09:23:89' / FITS header creation date YYYY-MM-DDTHH:MM:SS	Time FITS file was created by the SOC. For calibrated and derived it is the creation time of the product	YYYY-MM-DDTHH:MM:SS
Investigation_Area.name	MISSION = 'DART / Mission: DART	Name of mission	DART
Observing_System.name	HOSTNAME = 'LICIACube' / spacecraft name	LUKE is on the spacecraft named LICIACube	LICIACube
Observing_System_Component.name	INSTRUME = 'LUKE' / Instrument name	Instrument name	LUKE
	APID	Application ID of science image data: the images themselves	TBR
	TARGET = 'DIMORPHOS / Target Object	Primary target object	"DIMORPHOS"
dart:mission_phase	MPHASE = 'approach' / phase of the mission	The DART mission is divided into phases; this keyword states the phase during which the image was acquired.	"approach", "final"
dart:liciacube_sclk_image_time	IMG_TIME = '298271898.012320 / [sec] image TOV	Start of image capture time in spacecraft clock notation. Numeric number preceding the decimal point is integer seconds. Numeric number after the decimal point is subsecond clock ticks, where each tick represents 1/256 of second.	Time since t=0, as defined in the SCLK kernel.  Left blank when not available.
	IMG.UTC = '2022 OCT 01 10:28:09.600' / Image TOV in UTC	Start of image capture time in UTC.	
	SCLKNAME = 'liciacube_sclk_0000.tsc' / SCLK file used for IMG.UTC	Name of SCLK file used to compute IMG.UTC	
dart:readout_time	READOUT = '2956.25' / Readout time in microsec	Global readout time in microseconds.	From 2956.25 microsec to 333333 microsec
img:exposure_duration_	EXPTIME = '0.156789' / [sec] Exposure time	Image exposure time in seconds	0.00002882s to 338.16s.
dart:gain	GAIN= 1 /Gain setting	Detector gain setting	1., 2., 10., or 30. Float
dart:binning	BINNING = 'ON' / Binning status	If binning is on or not.	'ON' or 'OFF'

dart>window_x_start	WINXSTA = '0' / X origin of window	Column where window starts. Window coordinates are with respect to a 1088 x 2048 image. The upper left hand corner of the image plus header row is coordinate 0,0. -1 if second windowing not applied.	-1 to 1087
dart>window_y_start	WINYSTA = '0' / Y origin of window	Row where window starts. Window coordinates are with respect to a 1088 x 2048 image. The upper left hand corner of the image plus header row is coordinate 0,0. -1 if second windowing not applied.	-1 to 2047
dart>window_x_end	WINXEND= '2048' / X end of window	Column where window ends. Window coordinates are with respect to a 1088 x 2048 image. The upper left hand corner of the image plus header row is coordinate 0,0. -1 if second windowing not applied.	2 to 1088
dart>window_y_end	WINYEND= '2048' / Y end of window	Row where window ends. Window coordinates are with respect to a 1088 x 2048 image. The upper left hand corner of the image plus header row is coordinate 0,0. -1 if second windowing not applied.	2 to 2048
	TRUNC= 'MSB' / Truncation mode	Defines whether the data are truncated using MSB or LSB. When binning is enabled, the truncation mode is MSB. When binning is disabled, the truncation mode is LSB.	"MSB" or "LSB".
	RCNTTHST = 1 / thruster firing flag	Flag whether thrusters were fired within one settling time before this image. =1 true, =0 false (TBR)	0 or 1. Integer
	AOCWX = 0 / [deg/s] rotation speed on X axis	Rotation speed of LICIAcube frame X axis	
	AOCWY = 0 / [deg/s] rotation speed on Y axis	Rotation speed of LICIAcube frame Y axis	
	AOCWZ = 0 / [deg/s] rotation speed on Z axis	Rotation speed of LICIAcube frame Z axis	
dart:detector_temp	DETTEMP = 18.333 / [degC] Detector temperature	Detector temperature	
	EPHMETA = 'LCC210701-EMK-RN-L211124-V001.mk' / Ephemeris metakernel to be used	Ephemeris metakernel to be used	
	ATTMETA = 'LCC201228-AMK-RN-L221124-V001.mk' /	Attitude metakernel to be used	

	Attitude metakernel to be used		
	SOCQUATA = '0.10808003767484.' /SC quaternion in J2000 (q0) using A CORT UTC	Spacecraft quaternion computed by the SOC using SPICE and CORT UTC	
dart.correct_image_time	CORT UTC	UTC time at mid-exposure time used to define attitude and representative observing geometry.	Time at mid exposure used to define attitude and representative geometric attributes. Since the acquisition operation is verified to be successful after a 250 ms delay, from the effective time of acquisition (defined as tCUC), this value is computed as: CORT UTC = tCUC - 0.250s + EXPTIME/2
	CORTJDAT	Julian Ephemeris Date based at mid exposure (= IMGTIME+0.5EXPTIME) used to define attitude and representative observing geometry.	Time at mid exposure used to define attitude and representative geometric attributes. Since the acquisition operation is verified to be successful after a 250 ms delay, from the effective time of acquisition (defined as tCUC), this value is computed converting in Julian Ephemeris Date the following value (computed in UTC): CORT UTC = tCUC - 0.250s + EXPTIME/2
	SOCQUATX= '-0.674302095900066' /SC quaternion in J2000 (q1) using CORT UTC		
	SOCQUATY= '-0.32453616895850' /SC quaternion in J2000 (q2) using CORT UTC		
	SOCQUATZ = '0.65445524213556' /SC quaternion in J2000 (q3) using appropriate CORT UTC time		
	BORE_RA = '326.459994' / [deg] Boresight right ascension	Boresight right ascension	0 to 360 degrees.
	BORE_DEC = '-38.093559' / [deg] Boresight declination	Boresight declination	-90 to 90 degrees



	CELN_CLK = '28.16' / [deg] Celestial north clock angle	Celestial north clock angle	0 to 360 degrees.
	ECLN_CLK = '49.30' / [deg] Ecliptic north clock angle	Ecliptic north clock angle	0 to 360 degrees.
	SUN_CLK = '318.40' / [deg] Sun clock angle	Sunward direction clock angle	0 to 360 degrees.
	PXARCS = '1.02' / [arcsec] Pixel scale	Pixel scale in arcsec	Either 1.02 arcsec if BINNING = ON or 0.512 arcsec if BINNING = OFF.
	PXMRAD = '4.96' / [microradians] Pixel scale	Instantaneous field of view of a pixel, in microradians. If BINNING = ON, this value is reported for a 2x2 binned pixel.	Either 4.96 urad if BINNING = ON or 2.48 urad if BINNING = OFF.
	PHDIST = '1.04' / [AU] Heliocentric distance - Primary	Distance between the sun and the primary target, in AU	Calculated for selected TARGET values only (e.g., Didymos, Dimorphos, etc.), otherwise set to -1E32.
	PSCRNG = '4.2622E+02' / [km] Spacecraft range - Primary	Distance between the spacecraft and the primary target center, in km	Calculated for selected TARGET values only (e.g., Didymos, Dimorphos, etc.), otherwise set to -1E32.
	PSPHASE = '55.98' / [deg] Solar phase angle - Primary	Angle between the sunward direction and the direction to the spacecraft, as observed from the primary target.	0 to 180 degrees. Calculated for selected TARGET values only (e.g., Didymos, Dimorphos, etc.), otherwise set to -1E32.
	PSELON = '73.49' / [deg] Solar elongation - Primary	Angle between the sunward direction and the direction to the primary target, as observed from the spacecraft.	0 to 180 degrees. Calculated for selected TARGET values only (e.g., Didymos, Dimorphos, etc.), otherwise set to -1E32.
	PPPCLK = '228.64' / [deg] Positive pole clock angle - Primary	Positive pole clock angle of the primary target	0 to 360 degrees. Calculated for selected TARGET values only (e.g., Didymos, Dimorphos, etc.), otherwise set to -1E32.
	PSUBLAT = '38.04' / [deg] Sub-observer latitude - Primary	Sub-observer latitude of the primary target	-90 to 90 degrees. Calculated for selected TARGET values only (e.g., Didymos, Dimorphos, etc.), otherwise set to -1E32.
	PSUBLON = '146.65' / [deg] Sub-observer longitude - Primary	Sub-observer east longitude of the primary target	0 to 360 degrees. Calculated for selected TARGET values only

			(e.g., Didymos, Dimorphos, etc.), otherwise set to -1E32.
	PSSOLLAT = '-1.07' / [deg] Sub-solar latitude - Primary	Sub-solar latitude of the primary target	-90 to 90 degrees. Calculated for selected TARGET values only (e.g., Didymos, Dimorphos, etc.), otherwise set to -1E32.
	PSSOLLON = '190.18' / [deg] Sub-solar longitude - Primary	Sub-solar east longitude of the primary target	0 to 360 degrees. Calculated for selected TARGET values only (e.g., Didymos, Dimorphos, etc.), otherwise set to -1E32.
	SHDIST = '1.04' / [AU] Heliocentric distance - Secondary	Distance between the sun and the secondary target, in AU	Calculated for selected SECTAR values only (e.g., Didymos, Dimorphos, etc.), otherwise set to -1E32.
	SSCRNG = '4.2623E+02' / [km] Spacecraft range - Secondary	Distance between the spacecraft and the secondary target center, in km	Calculated for selected SECTAR values only (e.g., Didymos, Dimorphos, etc.), otherwise set to -1E32.
	SSPHASE = '56.14' / [deg] Solar phase angle - Secondary	Angle between the sunward direction and the direction to the spacecraft as seen from the secondary target	0 to 180 degrees. Calculated for selected SECTAR values only (e.g., Didymos, Dimorphos, etc.), otherwise set to -1E32.
	SSELON = '73.59' / [deg] Solar elongation - Secondary	Angle between the sunward direction and the direction to the secondary target, as observed from the spacecraft.	0 to 180 degrees. Calculated for selected SECTAR values only (e.g., Didymos, Dimorphos, etc.), otherwise set to -1E32.
	SPPCLK = '228.64' / [deg] Positive pole clock angle - Secondary	Positive pole clock angle of the secondary target	0 to 360 degrees. Calculated for selected SECTAR values only (e.g., Didymos, Dimorphos, etc.), otherwise set to -1E32.
	SSUBLAT = '38.09' / [deg] Sub-observer latitude - Secondary	Sub-observer latitude of the secondary target	-90 to 90 degrees. Calculated for selected SECTAR values only (e.g., Didymos, Dimorphos, etc.), otherwise set to -1E32.
	SSUBLON = '146.46' / [deg] Sub-observer longitude - Secondary	Sub-observer east longitude of the secondary target	0 to 360 degrees. Calculated for selected SECTAR values only (e.g., Didymos, Dimorphos, etc.), otherwise set to -1E32.
	SSSOLLAT = '-1.07' / [deg] Sub-solar latitude - Secondary	Sub-solar latitude of the secondary target	-90 to 90 degrees. Calculated for selected SECTAR values only (e.g., Didymos,

			Dimorphos, etc.), otherwise set to -1E32.
	SSSOLON = '190.18' / [deg] Sub-solar longitude - Secondary	Sub-solar east longitude of the secondary target	0 to 360 degrees. Calculated for selected SECTAR values only (e.g., Didymos, Dimorphos, etc.), otherwise set to -1E32.

### 5.2.6 LICIACube LUKE Calibrated Image Data

The LUKE Level-2 (calibrated) image format is a single HDU FITS file containing a 3 (bands) x 1088 (lines) x 2048 (samples) active image array in 32-bit floating point radiance units. Windowed or binned images have less pixels than this original format.

Metadata contained in the Level-2 LEIA images FITS header and its mapping to class and attribute in the PDS4 .xml label structure is listed in Table 14, where different or absent in Table 12 referring to Level-0 LUKE images. Metadata descriptions may be abbreviated in the FITS header, with full descriptions in the following table.

The Class.Attribute Name column is left blank for FITS keywords not mapped to the .xml label.

Table 14. LUKE Level-2 additional image metadata

Class.Attribute Name	Keyword and example	Description	Range of values
Element_Array. data_type	BITPIX = 32 / number of bits per data pixel	LUKE raw images delivered to the SOC will always be 8 bit. Calibrated images are the result of applying the calibration files, themselves in 32-bit floating point, to the raw images. All are stored in big-endian as per the FITS standard.	32
	RADCONV = 1.0 / Radiance conversion factor	Radiance conversion factor	
	NAXIS = 3 / number of data axes	Number of data axes. All LUKE calibrated images have 3 axes	3
Axis_Array. sequence_number	NAXIS3 = 3 / length of data axis 3	Number of bands. LUKE calibrated have 3 bands	3
dart:liciacube_calibration_file	CALFILE='LICIACube_LUKE_CAL_001.fits' / ref calibration file	Name of calibration file used.	Determined by file naming convention.

	PLANE1 = 'RED' / Color of image plane	Color of image plane.	'RED'
	PLANE2 = 'GREEN' / Color of image plane	Color of image plane.	'GREEN'
	PLANE3 = 'BLUE' / Color of image plane	Color of image plane.	'BLUE'
	BADMASKV = '-1E30' / Value assigned to bad pixels	Pixel value assigned to bad pixels by the SOC	-1E30
Special_Constants. missing_constant	MISPXVAL = '1E32' / Value assigned to missing pixels	Keyword created by MOC; value updated by pipeline	1E32
Special_Constants. high_instrument_saturation	SATPXVAL = '1E30' / Value assigned to saturated pixels	Pixel value assigned to saturated pixels by the SOC	1E30

### 5.2.7 LICIACube LUKE Raw Pixel Values

Non-valid pixels (e.g., missing data, dead pixels, etc.) may be present in small numbers within the calibrated image arrays:

- Bad pixels will be associated with the value -1E30
- Missing pixels (e.g. due to downlink problems) will be associated to the value 1E32
- Saturated pixels will be associated to 1E30

### 5.2.8 LICIACube LUKE Calibration File Formats

LICIACube LUKE has two calibration files:

- one with with 2048 samples, 1088 lines and 7 bands, containing: bad pixel map, bias, dark, flat parameters, as described in Table 15;
- one with a [3, 3, 2228224, 11] array containing the spline interpolation parameters, as described in Table 16 (2228224 is the number of pixels in the LUKE raw image, i.e., 2048 x 1088).

Table 15. liciacube\_luke\_cal\_gen\_001.fits image metadata

Class.Attribute Name	Keyword and example	Description	Range of values
	SIMPLE = T / file conforms to FITS standard	Required in FITS standard	T
Element_Array. data type	BITPIX = 32 / number of bits per data pixel	LUKE calibration files has 32 bit per pixel	32
	NAXIS = 3 / number of data axes	Number of data axes.	3
Axis_Array. sequence number	NAXIS1 = 2048 / length of data axis 1	Number of rows.	2048
Axis Array.	NAXIS2 = 1088 / length of data axis 2	Number of rows.	1088

sequence number			
Axis_Array. sequence number	NAXIS3 = 7 / length of data axis 3	Number of bands.	7
	CALFILE='liciacube_luke_cal_gen_001.fits' ' / ref bias file	Name of calibration file used.	Determined by file naming convention.
	PLANE1 = 'BIAS' / Bias Plane	Bias plane	'BIAS'
	PLANE2 = 'BAD PIXEL MAP' / Bad pixel map plane.	Bad pixel map plane, =0 good pixel, =1 bad pixel	'BAD PIXEL MAP'
	PLANE3 = 'DARK1' / Dark current plane 1	Dark current plane 1	'DARK1'
	PLANE4 = 'DARK2' / Dark current plane 2	Dark current plane 2	'DARK2'
	PLANE5 = 'FLAT RED' / Flat for red channel	Flat matrix for red plane	'FLAT RED'
	PLANE6 = 'FLAT GREEN' / Flat for green channel	Flat matrix for green plane	'FLAT GREEN'
	PLANE7 = 'FLAT BLUE' / Flat for blue channel	Flat matrix for blue plane	'FLAT BLUE'
	BADMASKV = '-1E30' / Value assigned to bad pixels	Pixel value assigned to bad pixels by the SOC	-1E30

Table 16. liciacube\_luke\_cal\_col\_001.fits image metadata

Class.Attribute Name	Keyword and example	Description	Range of values
	SIMPLE = T / file conforms to FITS standard	Required in FITS standard	T
Element_Array. data_type	BITPIX = 32 / number of bits per data pixel	LUKE calibration files has 32 bit per pixel	32
	NAXIS = 4 / number of data axes	Number of data axes.	4
Axis_Array. sequence number	NAXIS1 = 11 / length of data axis 1	Maximum number of parameters.	11
Axis_Array. sequence number	NAXIS2 = 2228224 / length of data axis 2	Number of pixels.	2228224
Axis_Array. sequence number	NAXIS3 = 3 / length of data axis 3	Number of parameter lists.	3
Axis_Array. sequence number	NAXIS4 = 3 / length of data axis 4	Number of channels.	3
	CALFILE='liciacube_luke_cal_col_001.fits' ' / ref bias file	Name of calibration file used.	Determined by file naming convention.

### 5.3 Label and Header Descriptions

All LICIAcUBE LEIA science and ancillary data products contain date and time information that can be used to sort and correlate data products. Data product labels are in XML format and are PDS4 compliant.

## 6 Applicable Software

At the current time the DART project has no plans to release any mission specific utility programs. Data products found in the archive can be viewed with any PDS4 compatible software utility. LICIAcube image data are formatted as FITS data files which can be read by any FITS compatible software viewer or FITS library.

## 7 Appendices

### 7.1 Appendix 1: List of acronyms

ADC	Analog to Digital Converter
APID	Application ID
AR	Anti-Reflection
ASI	Agenzia Spaziale Italiana
CDS	Correlated Double Sampling
CFA	Color Filter Array
CMOS	Complementary Metal-Oxide Semiconductor
DART	Double Asteroid Redirection Test
DMAP	Data Management and Archive Plan
DN	Digital Numbers
DSN	Deep Space Network
FITS	Flexible Image Transport System
FoV	Field of View
FPGA	Field Programmable Gate Array
fps	frames per second
GNC	Guidance Navigation and Control system
HDU	Header Data Unit
IAT	Images Acquisition Table
IAU	International Astronomical Union
ICD	Interface Control Document
LCC	LICIAcube
LEIA	Liciacube Explorer Imaging for Asteroid
LSOC	LICIAcube Science Operation Center
LUKE	Liciacube Unit Key Explorer
LVDS	Low-Voltage Differential Signaling
MATISSE	Multi-purpose Advanced Tool for the Instruments for the Solar System Exploration
MCC	Mission Control Center
MSB	Most Significant Bit
NanoCU	Nano Computational Unit
PCB	Printed Circuit Board
PDS	Planetary Data System
PGA	Programmable Gain Amplifier
PNG	Portable Network Graphics
RAM	Random Access Memory
RGB	Red-Green-Blue
SBMT	Small Body Mapping Tool

SBN	Small Bodies Node
SCLK	Spacecraft Clock
SIS	Software Interface Specification
SOC	Science Operation Center
SSDC	Space Science Data Center
TBD	To Be Defined
tCUC	Timestamp in the CCSDS Unsegmented Code
UTC	Universal Time Coordinated
XML	Extensible Markup Language